



Prophylaxis for Hereditary Angioedema with Lanadelumab and C1 Inhibitors: Effectiveness and Value

Final Evidence Report

November 15, 2018

Prepared for



ICER Staff and Consultants	University of Washington School of Pharmacy Modeling Group
<p>Grace A. Lin, MD, MAS Associate Professor of Medicine and Health Policy University of California, San Francisco</p>	<p>Josh Carlson, PhD, MPH Associate Professor The Comparative Health Outcomes, Policy and Economics (CHOICE) Institute, Department of Pharmacy University of Washington</p>
<p>Foluso Agboola, MBBS, MPH Director, Evidence Synthesis Institute for Clinical and Economic Review</p>	<p>Solomon Lubinga, PhD, MSc Senior Fellow The Comparative Health Outcomes, Policy and Economics (CHOICE) Institute, Department of Pharmacy University of Washington</p>
<p>Sumeyye Samur, PhD, MS Health Economist Institute for Clinical and Economic Review</p>	<p>*The role of the University of Washington Department of Pharmacy Modeling group is limited to the development of the cost-effectiveness model, and the resulting ICER reports do not necessarily represent the views of UW.</p>
<p>Rick Chapman, PhD, MS Director of Health Economics Institute for Clinical and Economic Review</p>	
<p>Laura Cianciolo, BA Program Associate Institute for Clinical and Economic Review</p>	
<p>Matt Seidner, BS Program Director Institute for Clinical and Economic Review</p>	
<p>Steven D. Pearson, MD, MSc President Institute for Clinical and Economic Review</p>	
<p>David Rind, MD, MSc Chief Medical Officer Institute for Clinical and Economic Review</p>	

None of the authors above disclosed any conflicts of interest.

DATE OF

PUBLICATION: November 15, 2018

Grace Lin served as the lead author for the report and wrote the background, other benefits, and contextual considerations sections of the report. Foluso Agboola led the systematic review and authorship of the comparative clinical effectiveness section. Rick Chapman was responsible for oversight of the cost-effectiveness analyses and developed the budget impact model with Sumeyye Samur. Laura Cianciolo authored the section on coverage policies and clinical guidelines in collaboration with Matt Seidner. Josh Carlson and Solomon Lubinga developed the cost-effectiveness model and authored the corresponding sections of the report. David Rind and Steve Pearson provided methodologic guidance on the clinical and economic evaluations. We would also like to thank Katherine Fazioli and Leslie Xiong for their contributions to this report.

About ICER

The Institute for Clinical and Economic Review (ICER) is an independent non-profit research organization that evaluates medical evidence and convenes public deliberative bodies to help stakeholders interpret and apply evidence to improve patient outcomes and control costs. Through all its work, ICER seeks to help create a future in which collaborative efforts to move evidence into action provide the foundation for a more effective, efficient, and just health care system. More information about ICER is available at <http://www.icer-review.org>.

The funding for this report comes from government grants and non-profit foundations, with the largest single funder being the Laura and John Arnold Foundation. No funding for this work comes from health insurers, pharmacy benefit managers, or life science companies. ICER receives approximately 19% of its overall revenue from these health industry organizations to run a separate Policy Summit program, with funding approximately equally split between insurers/PBMs and life science companies. The treatments included in this review are not manufactured by any members of this program. For a complete list of funders and for more information on ICER's support, please visit <http://www.icer-review.org/about/support/>.

About CTAF

The California Technology Assessment Forum (CTAF) – a core program of ICER – provides a public venue in which the evidence on the effectiveness and value of health care services can be discussed with the input of all stakeholders. CTAF seeks to help patients, clinicians, insurers, and policymakers interpret and use evidence to improve the quality and value of health care.

The CTAF Panel is an independent committee of medical evidence experts from across California, with a mix of practicing clinicians, methodologists, and leaders in patient engagement and advocacy. All Panel members meet strict conflict of interest guidelines and are convened to discuss the evidence summarized in ICER reports and vote on the comparative clinical effectiveness and value of medical interventions. More information about CTAF is available at <http://www.ctaf.org>.

The findings contained within this report are current as of the date of publication. Readers should be aware that new evidence may emerge following the publication of this report that could potentially influence the results. ICER may revisit its analyses in a formal update to this report in the future.

In the development of this report, ICER's researchers consulted with several clinical experts, patients, manufacturers, and other stakeholders. The following clinical experts provided input that helped guide the ICER team as we shaped our scope and report. None of these individuals is responsible for the final contents of this report or should be assumed to support any part of this report, which is solely the work of the ICER team and its affiliated researchers.

*For a complete list of stakeholders from whom we requested input, please visit:
<https://icer-review.org/material/angioedema-stakeholder-list/>*

Expert Reviewers

Marco Cicardi, MD

Professor of Medicine

Università degli Studi di Milano, Italy

Dr. Cicardi has received consulting fees in excess of \$5,000 from CSL Behring and Shire; serves as a speaker for CSL Behring, Pharming, and Shire; has received research and educational support from Pharming and Shire; and was a primary investigator in clinical trials of Haegarda, Ruconest, and lanadelumab.

Stephanie Smith

Patient with HAE

Stephanie Smith serves as a patient advocate for Haegarda (CSL Behring) and has received more than \$5,000 in honorarium in this role.

Table of Contents

Executive Summary	ES1
1. Introduction	1
1.1 Background	1
1.2 Scope of the Assessment	5
1.3 Definitions	8
1.4 Insights Gained from Discussions with Patients and Patient Groups	9
1.5 Research, Development, and Manufacturing Costs	10
1.6. Potential Cost-Saving Measures in HAE.....	10
2. Summary of Coverage Policies and Clinical Guidelines	11
2.1 Coverage Policies	11
2.2 Clinical Guidelines	12
3. Comparative Clinical Effectiveness	15
3.1 Overview	15
3.2 Methods	16
3.3 Results	17
3.4 Summary and Comment	29
4. Long-Term Cost Effectiveness	32
4.1 Overview	32
4.2 Methods	32
4.3 Results	43
4.4 Summary and Comment	49
5. Potential Other Benefits and Contextual Considerations.....	51
5.1 Potential Other Benefits	52
5.2 Contextual Considerations.....	52
6. Value-Based Price Benchmarks.....	54
7. Potential Budget Impact	55
7.1 Overview	55
7.2 Methods	55
7.3 Results	56

8. Summary of the Votes and Considerations for Policy	59
8.1 About the CTAF Process	59
8.2 Voting Results	61
8.3 Roundtable Discussion and Key Policy Implications	65
References	73
Appendix A. Search Strategies and Results.....	81
Appendix B. Previous Systematic Reviews and Technology Assessments	86
Appendix C. Ongoing Studies.....	87
Appendix D. Comparative Clinical Effectiveness Supplemental Information.....	88
Appendix E. Comparative Value Supplemental Information.....	102
Appendix F. Public Comments	106
Appendix G. Conflict of Interest Disclosures	108

List of Acronyms Used in this Report

AAAAI	American Academy of Allergy, Asthma, and Immunology
ACE	Angiotensin-converting enzyme
AE	Adverse event
AE-QoL	Angioedema Quality of Life Questionnaire
AHRQ	Agency for Healthcare Research and Quality
BI	Budget impact
C1-INH	C1-inhibitor or C1-esterase inhibitor
CI	Confidence interval
CMS	Centers for Medicare and Medicaid Services
DHCS	California Department of Health Care Services
EAACI	European Academy of Allergy and Clinical Immunology
FDA	United States Food and Drug Administration
GDP	Gross domestic product
HADS	Hospital Anxiety and Depression Scale
HAE	Hereditary angioedema
HAEA	Hereditary Angioedema Association
HAE-QoL	Hereditary Angioedema Quality of Life Questionnaire
HAWK	Hereditary Angioedema International Working Group
HMWK	High-molecular-weight-kininogen
JTF	Joint task force
LCD	Local coverage determination
NDC	National coverage determination
NR	Not reported
PICOTS	Population, Interventions, Comparisons, Outcomes, Timing, Setting, and Study Design
PRISMA	Preferred reporting items for systematic reviews and meta-analyses
QALY	Quality-adjusted life year
RCT	Randomized controlled trial
SAE	Serious adverse event
UHC	UnitedHealthcare
URTI	Upper respiratory tract infection
USPSTF	United States Preventive Services Task Force
US	United States
WAC	Wholesale acquisition cost
WAO	World Allergy Organization
WPAI	Work Productivity and Activity Impairment Questionnaire
WTP	Willingness to pay

Executive Summary

Background

Hereditary angioedema (HAE) is a rare autosomal dominant genetic disorder characterized by recurrent episodes of tissue swelling (angioedema) in various parts of the body.¹ Most cases of HAE are caused by mutations in the gene that codes for C1 inhibitor (C1 esterase inhibitor; C1-INH).² Low C1-INH levels (HAE Type 1) or dysfunctional C1-INH (HAE Type 2) lead to buildup of bradykinin, a potent vasodilator, resulting in the development of angioedema.³ The disease affects approximately 1 in 50,000 individuals, with males and females equally affected, and has been reported in all races and ethnicities.^{4,5}

Attacks are characterized by mild to severe tissue swelling at one or more sites in the body (e.g., under the skin, [subcutaneous, occurs in 91% of patients], under a mucous membrane such as in the bowel wall [causing abdominal pain, occurs in 74% of patients], and in the upper airway [laryngeal swelling, occurs in 47% of patients]),⁶ and cause variable disability. Laryngeal edema carries a 30% risk of death due to asphyxiation if untreated;⁷ however, with treatment, death is rare. Episodes are usually self-limited, lasting on average between two to five days.⁸ Based on studies in the United States (US) and Europe, attack frequency and severity is variable.^{1,7} Most patients report having zero to four attacks per month, and a few patients report having multiple attacks per week.^{9,10}

Management of HAE

Medications for HAE can be categorized into on-demand therapies, which are taken during an attack to minimize the severity of angioedema symptoms and resolve symptoms as quickly as possible; short-term (or peri-procedural) prophylaxis taken prior to activities known to trigger attacks; and long-term prophylaxis of attacks to reduce disease burden. Treatment for HAE is costly; medications for on-demand therapy range in cost from \$5,000 to more than \$12,000 per attack treated in the US, and treatment with medications for long-term prophylaxis may cost upwards of \$500,000 annually.¹¹

Medications for *on-demand therapy* for acute attacks either provide replacement of C1-INH or target the kallikrein-kinin pathway. Home and/or self-administration of medications for acute attacks is preferable and improves outcomes such as time to symptom resolution and quality of life compared with administration in a clinic or hospital.¹²⁻¹⁵ Data suggest that 79-95% of infusions are administered at home, either by the patient, home health nurse, or caregiver.¹⁶⁻¹⁸

The goal of *long-term prophylaxis* for HAE patients is to prevent or reduce the frequency and severity of HAE attacks. Guidelines from multiple professional societies recommend individualized

decisions between patients and physicians with regard to starting long-term prophylaxis, considering the patient’s disease burden, quality of life, availability of resources, and patient preferences, rather than a prescribed number of attacks or disability.^{13,19,20} Long-term prophylaxis may or may not need to be lifelong, depending on the patient's clinical course, and the need for prophylaxis should be periodically reviewed. This review focuses on C1-INHs and lanadelumab for long-term prophylaxis of HAE 1/2 (Table ES1).

Table ES1. Treatments for Long-Term Prophylaxis for HAE 1/2 Discussed in Report

Drug (Brand Name)	Manufacturer	US FDA Approval Year	Mechanism of Action	Method of Delivery	Approved Population
Plasma-Derived C1-INH (Cinryze®)	Shire Plc	2008	C1-INH replacement	Intravenous	Ages 6 and older
Plasma-Derived C1-INH (Haegarda®)	CSL Behring GmbH	2017	C1-INH replacement	Subcutaneous	Ages 12 and older
Lanadelumab (Takhzyro®)	Shire Plc	2018	Kallikrein inhibitor	Subcutaneous	Ages 12 and older

There are two C1-INHs currently approved for long-term prophylaxis for HAE 1/2 – Cinryze® (Shire Plc), an intravenous human plasma-derived C1-INH approved for patients ages six and older, and Haegarda® (CSL Behring GMBH), a subcutaneous human plasma-derived C1-INH approved for patients 12 and older. The C1-INHs work by increasing the C1-INH levels in the body to prevent accumulation of bradykinin and onset of angioedema. Cinryze requires intravenous (IV) administration every three to four days, and some patients may need higher than typical doses to achieve a reduction in attacks. Haegarda is taken twice weekly as a subcutaneous (SC) injection. Lanadelumab (Takhzyro®, Shire Plc) is a newly-developed monoclonal antibody that was recently approved for long-term prophylaxis in HAE patients ages 12 and older. It inhibits plasma kallikrein, preventing formation of bradykinin and therefore decreasing the risk of developing angioedema. It is administered subcutaneously every two or four weeks.

Insights Gained from Discussions with Patients and Patient Groups

HAE can have significant effects on patients’ quality of life. Attacks can be debilitating and life-threatening, depending on the site and severity of the attack. Due to the unpredictability of attacks and the variability in attack frequency and severity, some patients describe high burdens from HAE on their daily lives including anxiety about potential attacks, the need to carry on-demand therapy, and the need to consider whether adequate medical care is accessible when planning activities. Patients also report that due to the unpredictability of attacks and the variable disability attacks cause, HAE can have a significant effect on work or school in terms of missed days for attacks and can hinder career or educational advancement. HAE not only affects patients but their caregivers

as well. Caregivers, often parents of children with HAE, may also need to take time off work to care for an HAE patient.

Studies have shown that almost three-quarters of HAE patients noted that the disease had a significant impact on their quality of life, including anxiety (15% of patients) and depression (almost 40% of patients) related to their ability to carry out daily activities, fear of attacks, and concerns about transmission of the condition to their children.²¹⁻²³ Quality of life appears to be worse in patients reporting more than five attacks per year.²¹ Studies that have characterized patients' quality of life using validated scales such as the SF-36 and EQ-5D have shown significant decreases in quality of life scores similar to those of patients with Crohn's disease or severe asthma.²⁴

Insurance coverage issues for HAE medications were mentioned by patients as a barrier to obtaining treatment. Patients report needing to spend time navigating the insurance system and also needing to rely on manufacturer programs to ensure access to treatment while dealing with insurance issues. Anecdotally, some patients reported difficulty attaining insurance coverage for simultaneous on-demand and long-term prophylactic therapy due to some insurers' requirement that patients be symptomatic to obtain on-demand therapy. Finally, given the variation in patient response to medications, patient groups worried that any restrictions placed on medications would adversely affect patient outcomes.

Potential Cost-Saving Measures in HAE 1/2

As described in its Final Value Assessment Framework (for more information, see <https://icer-review.org/final-vaf-2017-2019/>), ICER encouraged all stakeholders to suggest services (including treatments and mechanisms of care) currently used for people with HAE that could be reduced, eliminated, or made more efficient. We have not received any suggestions for potential cost-saving measures but continue to seek such input.

Comparative Clinical Effectiveness

We evaluated the comparative clinical effectiveness, tolerability, and safety of C1-INHs and lanadelumab for long-term prophylaxis of HAE 1/2 compared with no prophylaxis. In an earlier draft report, we also included Ruconest® (Pharming Healthcare, Inc.), a recombinant, intravenous C1-INH; however, since Ruconest is no longer under consideration for FDA approval for long-term prophylaxis, we have removed it from the review.²⁵ We identified three pivotal Phase III randomized trials, one each for Cinryze, Haegarda, and lanadelumab, that assessed the efficacy of long-term prophylaxis with the specified drug compared with placebo and have summarized trial characteristics and results below. Due to differences in trial entry criteria (particularly age and baseline attack rates), small study populations, and differences in study design, we did not perform quantitative indirect comparison of the three drugs.

Clinical Benefits

All the drugs reviewed appeared to be effective in reducing the number of HAE attacks per month compared with placebo (Table ES2). However, no trials reported mortality data. We also found no head-to-head comparisons of the drugs, and so have insufficient evidence to assess whether one treatment is superior to another for long-term prophylaxis for HAE 1/2. All the trials were judged to be of fair quality.

Table ES2. Clinical Efficacy Compared with Placebo of Medications for Long-Term Prophylaxis of HAE 1/2

	Mean HAE Attacks/Month (Prophylaxis vs. Placebo)	Percentage Reduction in Total HAE Attack Compared to Placebo
Cinryze vs. Placebo – Zuraw 2010		
Cinryze 1,000 IU	2.1 vs. 4.2*	50.5%*
Haegarda vs. Placebo – COMPACT Trial		
Haegarda 40 IU/kg	1.2 vs. 3.6 [†]	55.0%
Haegarda 60 IU/kg	0.5 vs. 4.0 [†]	84.0%
Lanadelumab vs. Placebo – HELP Trial		
Lanadelumab 150 mg q4weeks	0.5 vs. 2.0*	76.0%
Lanadelumab 300 mg q4weeks	0.5 vs. 2.0 [†]	73.0%
Lanadelumab 300 mg q2weeks	0.3 vs. 2.0 [†]	87.0%

Results are rounded to one decimal place

*Estimated from result presented over 12 weeks.

[†]p value<0.001.

Cinryze

The pivotal trial for Cinryze (Zuraw 2010) was a cross-over RCT of 22 patients, ages six years and older, who had two or more HAE attacks per month.²⁶ Participants were treated with either 1,000 IU of Cinryze or placebo over two 12-week periods, and the primary outcome was patient-reported HAE attack rates. In this study, prophylactic treatment with Cinryze significantly reduced the frequency (mean 6.26 vs. 12.73 attacks over 12 weeks), severity, and duration of HAE attacks when compared to no prophylaxis. A second randomized, crossover trial (Aygören-Pürsün 2018) assessed the efficacy of Cinryze in an exclusively pediatric population and found that treatment with Cinryze 500 IU or 1,000 IU twice weekly reduced the monthly mean HAE attack rate by 71%-85%.²⁷ A single-arm, open-label extension study of the Zuraw 2010 trial conducted in 146 participants also showed a statistically significant decrease in the mean monthly HAE attack rate compared with historical attack rates (0.47 vs. 4.7 attacks/month).²⁸ Finally, Cinryze appeared to improve health-related quality of life based on increased SF-36 scores in the treatment groups.

Haegarda

The COMPACT study was a crossover RCT of 90 patients, 12 years and older, who had two or more HAE attacks per month requiring immediate medical attention.²⁹ Participants were treated with Haegarda 40 IU/kg or 60 IU/kg or placebo, and followed over two 16-week treatment periods. The primary outcome was investigator-confirmed HAE attacks. Prophylactic treatment with Haegarda at both dosages significantly reduced the frequency, severity, and duration of HAE attacks when compared with no prophylaxis, with greater improvement shown in the 60 IU/kg group (84% mean reduction in attacks). Additionally, more patients on Haegarda prophylaxis were attack free over the duration of the study compared with placebo (38-40% vs. 9%). Haegarda also appeared to decrease the number of rescue therapies needed and HAE attack days per month, and as well as attack severity. In exploratory analyses examining the effect of Haegarda prophylaxis on quality of life, treatment with Haegarda appeared to result in clinically-meaningful improvement on work presenteeism and productivity.

Lanadelumab

The HELP study was a parallel arm RCT that included 125 patients, 12 years and older, who had one or more HAE attack per month.³⁰ Participants were treated with one of three dosing regimens of lanadelumab (150 mg every four weeks, 300 mg every four weeks, or 300 mg every two weeks) or placebo for 26 weeks. The main outcome was investigator confirmed HAE attacks. Prophylactic treatment with lanadelumab decreased the mean rate of HAE attacks between 73-87% compared with placebo, and also appeared to decrease attack severity. More patients in the lanadelumab treatment group were attack free over the duration of the study compared to placebo (39-44% vs. 2%). Furthermore, exploratory analyses showed that irrespective of baseline attack rates or prior treatment with C1-INHs, lanadelumab significantly reduced monthly HAE attack rates compared with placebo. Additionally, lanadelumab appeared to improve scores on the angioedema quality of life questionnaire compared with placebo.

Harms

The majority of adverse events reported in the pivotal trials of all three drugs were of mild or moderate severity; serious adverse events and adverse events leading to trial discontinuation were rare and general similar between trials arms. The most severe adverse reaction appeared to be thromboembolic events, which were seen in studies with Cinryze. Injection site reactions, particularly for the subcutaneously delivered drugs, were common (31% of patients on Haegarda in the COMPACT trial and 60% of patients on lanadelumab in the HELP trial). Mild infections, headaches, hypersensitivity, and dizziness were other common side effects.

Long-term safety data related to HAE prophylaxis were found only for Cinryze. Based on one long-term (up to 2.6 years), single arm, open label extension study, harms appear to be similar to those noted in the RCT. Long-term safety data are lacking for Haegarda and lanadelumab.

Controversies and Uncertainties

Although trials of long-term prophylaxis with C1-INH and lanadelumab showed benefits in reducing the frequency of HAE attacks with few harms, the evidence base is limited to small RCTs of short duration, leaving questions about the durability of treatment response and long-term safety. We have fewer concerns about the safety profile of C1-INHs given the longer experience with their use in both acute treatment and prophylaxis. Data on lanadelumab is extremely limited at this time and long-term safety is of particular concern because new biologic therapies frequently are found to have safety concerns in the years after they are introduced that were not detected in pre-approval trials.³¹ Data are also very limited in children under the age of 12 and no trials included pregnant or lactating women.

We also did not identify any trials comparing any of the drugs of interest to each other. While we considered conducting a network meta-analysis to indirectly compare the three drugs to each other, given the limited number of studies and the differences in inclusion criteria (e.g., age and baseline frequency of HAE attacks) and variation in outcomes measured, we did not pursue this analysis. We also found very limited data on patient-reported outcomes even though HAE can have significant effects on patients' quality of life; quality of life measures were infrequently and inconsistently measured across trials and few data were found on the impact of long-term prophylaxis on school, work, depression, or anxiety.

Summary and Comment

Results from our review of the drugs currently approved for long-term prophylaxis for HAE-1/2 suggest that they are safe and effective. All three drugs reviewed reduced the number and severity of HAE attacks compared with no long-term prophylaxis, and available data suggest few harms. Haegarda and lanadelumab have the additional benefit of being subcutaneously administered, which may decrease the burden and complexity of administration and avoid complications due to repeated intravenous infusions. However, the evidence base is limited due to small trial populations, short follow-up, lack of head-to-head trials, limited data on quality of life, and limited data in some populations (e.g., children and pregnant women).

Despite these limitations, the pivotal studies of C1-INHs demonstrate that they are effective in reducing the number of HAE attacks, and data from C1-INHs used for treatment of acute attacks suggest that long-term C1-INH use is safe. Thus, we rated the evidence for C1-INHs (Cinryze, Haegarda) as demonstrating a high certainty of substantial net benefit compared with no prophylaxis ("A"). For lanadelumab, because the results of the pivotal clinical trial are promising

but long-term safety data are lacking, we assigned a “promising but inconclusive” (“P/I”) rating. Finally, we cannot preclude differences in efficacy and safety among the drugs, and therefore determine the evidence to be insufficient (“I”) to judge net health benefits of each C1-INH to one another and lanadelumab.

Long-Term Cost Effectiveness

We conducted a cost effectiveness analysis using a Markov model comparing the three drugs approved for long-term prophylaxis of HAE-1/2 (Cinryze, Haegarda, and lanadelumab) with no prophylaxis. Patients were assumed to receive treatment for all moderate and severe acute attacks in the analysis. Our target population reflected the weighted average of the baseline characteristics across the three pivotal clinical trials for the interventions, with a mean age of 39.6 years, 68.4% female, mean weights of 88.8 kg (male) and 76.4 kg (female), and a baseline attack rate of 3.39 attacks per month.

The Markov model included two states: “alive with HAE” and “dead.” Each model cycle lasted one month, and we assumed that prophylactic therapies were taken on a lifelong basis. For each intervention, we calculated the number of attacks in each cycle, the probability of death given the number of attacks in each cycle, patient survival, time spent “attack free,” quality-adjusted survival, and health care costs. For each attack, we also tracked attack severity, anatomical location for severe attacks (i.e., laryngeal and non-laryngeal), mortality due to laryngeal attack only, attack-specific disutilities, and treatment setting (home, outpatient, emergency department [ED]), as well as outcomes such as ED visits, hospitalizations, and associated costs for each. We also included indirect productivity costs (e.g., missed work or school) for acute attacks in a scenario analysis.

The effect of prophylactic treatment on the number of attacks was derived from the key clinical trials and applied as a proportionate reduction in attack frequency. Attack severity data were drawn from a multicenter patient registry, and quality of life utilities were based on European data³² because of a lack of US data. Adverse events were not included in the model due to the lack of serious adverse events attributable to any of the prophylactic therapies during clinical trials. Outcomes were summed over a lifetime horizon for each intervention. Differences in survival, quality-adjusted survival, and costs between each prophylactic therapy and no prophylaxis were used to calculate incremental cost-effectiveness ratios. Key model assumptions are detailed in Table 4.2 of the report. Detailed explanations of model inputs, assumptions, and their rationale, as well as sensitivity analyses are presented in Section 4 of this report.

For this report, the base-case analysis used a US health care system perspective with a 3% discount rate for costs and health outcomes. All patients were assumed to have access to on-demand treatment for acute attacks in the comparator arm. For on-demand treatment, we computed the average costs per attack in each treatment setting as the cost of these drugs weighted by the proportion of attacks treated with each drug in each treatment setting. Tables ES3 and ES4 detail

the drug costs inputs for this model. Additionally, costs for administration and monitoring of both prophylactic therapy and on-demand therapy for acute attacks were included in the model, as well as health care utilization costs for on-demand therapy for acute attacks, including non-fatal laryngeal attacks. Finally, although ICER’s modified assessment framework for ultra-rare conditions calls for consideration of a co-base-case analysis taking a societal perspective, the societal costs of HAE-1/2 are small in relation to health care costs and thus we have included this analysis as a scenario.

Table ES3. Drug Cost Inputs for Drugs for Long-Term Prophylaxis

Drug Name, Labeled Dose, Administration Route	Unit	Big 4 (or FSS) Price per Package/Dose*	ASP per Unit/Dose†	Base-Case Treatment Duration
Cinryze, 1,000 IU Twice Weekly, Intravenous	500 IU	\$2,012	\$3,049	Lifetime
Haegarda, 60 IU/kg Twice Weekly, Subcutaneous‡	2,000 IU	\$1,393	---	Lifetime
	3,000 IU	\$2,090	---	
Lanadelumab, 300 mg Every 2 Weeks, Subcutaneous	300 mg	\$16,520	---	Lifetime

*Federal Supply Schedule price as of October 1, 2018.

†Average sales price as of June 13, 2018, plus 9% markup for administration in physicians’ office, home infusion, and hospital outpatient settings.

‡Haegarda dosing is weight-based, so gender-specific weight distributions were used to calculate the average number of 2,000 IU and 3,000 IU vials needed, accounting for wastage and selecting the vial combination with the minimum cost from all possible vial combinations.

Table ES4. Drug Cost Inputs for Drugs for On-Demand Treatment for Acute Attacks

	Berinert	Kalbitor	Firazyr	Ruconest
Dose Schedule	20 units/kg	30 mg	30 mg	50 units/kg
FSS per Dose*	\$4,174	\$11,174	\$7,178	\$10,112
ASP per Dose†	\$9,807	\$15,594	\$7,178	\$15,164
% Requiring Extra Dose	1.9%	12%	12.7%	6.6%

*Federal Supply Schedule or Big 4 price as of September 15, 2018.

†Average sales price as of June 13, 2018, plus 9% markup for administration in physicians’ office, home infusion, and hospital outpatient settings.

Base-Case Results

In the base case, long-term prophylaxis with all three drugs resulted in a lower number of acute attacks and higher QALYs compared to no long-term prophylaxis (Table ES5); however, the improvements came at a cost, with incremental cost-effectiveness ratios of \$328,000 to \$5,954,000 per QALY (Table ES6). There was no difference in survival among the strategies, since death is rare with appropriate treatment of HAE 1/2.

Table ES5. Base-Case Results

	No Prophylaxis	Cinryze	Haegarda	Lanadelumab
Total Costs – US Health System Perspective	\$9,953,000	\$14,396,000	\$10,343,000	\$11,274,000
Prophylaxis Drug Costs	\$0	\$9,469,000	\$8,897,000	\$9,970,000
Acute Treatment Costs	\$9,953,000	\$4,927,000	\$1,446,000	\$1,304,000
Acute Treatment Costs (Drugs)	\$9,205,000	\$4,557,000	\$1,391,000	\$1,206,000
Acute Treatment Costs (Other Services)	\$748,000	\$370,000	\$55,000	\$98,000
Lys	23.55	23.55	23.55	23.55
QALYs	17.47	18.21	18.65	18.66
# of Attacks	1,703	843	273	223

LY: life year, QALY: quality-adjusted life year

Table ES6. Incremental Results versus No Prophylaxis for the Base Case

	Cinryze	Haegarda	Lanadelumab
Total Costs – US Health System Perspective	\$4,443,000	\$390,000	\$1,321,000
Prophylaxis Drug Costs	\$9,469,000	\$8,897,000	\$9,970,000
Acute Treatment Costs	-\$5,026,000	-\$8,507,000	-\$8,648,000
Acute Treatment Costs (Drugs)	-\$4,648,000	-\$7,814,000	-\$7,999,000
Acute Treatment Costs (Other Services)	-\$378,000	-\$693,000	-\$650,000
LYs Gained	0.00	0.00	0.00
QALYs Gained	0.75	1.19	1.19
# of Attacks Avoided	860	1,430	1,480
ICER – US Health System Perspective	\$5,954,000	\$328,000	\$1,108,000
\$/Attack Avoided - US Health System Perspective	\$5,168	\$273	\$892

ICER: incremental cost-effectiveness ratio, LY: life year, QALY: quality-adjusted life year

*Incremental cost-effectiveness ratios are rounded to the nearest \$1,000; incremental cost-effectiveness ratios are rounded to the nearest \$10,000 when over \$1 million.

Sensitivity Analyses

However, our results were sensitive to a number of model parameters. We found that prophylactic drug acquisition costs, baseline attack rate, and the treatment effect (% mean reduction in attack frequency) in most cases had the largest impact on the incremental cost-effectiveness ratio (Figure ES1). Additionally, the probability that Haegarda and lanadelumab met cost-effectiveness thresholds from \$50,000 to \$500,000 per QALY ranged from 30% to 62%, and 3% to 14%, respectively. Cinryze did not meet a cost-effectiveness threshold up to \$500,000 in any simulation.

Figure ES1. One-Way Sensitivity Analysis for Long-Term Prophylactic Drugs for HAE 1/2

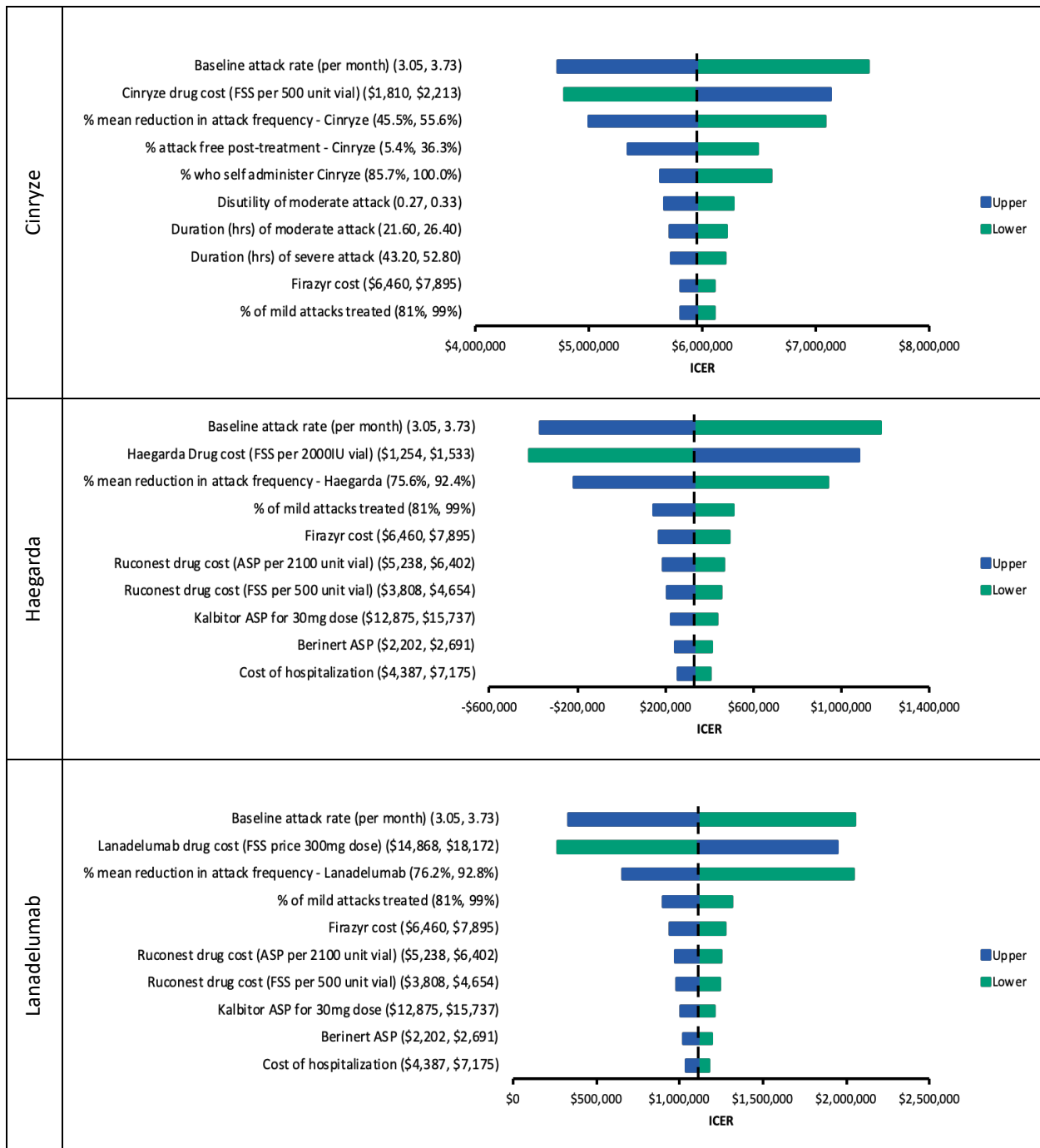

Scenario Analyses

Taking a modified societal perspective, we found that incremental cost-effectiveness ratios ranged from \$216,000 for HAE 1/2 patients receiving Haegarda for long-term prophylaxis to \$5,852,000 for patients receiving Cinryze.

For lanadelumab, package labeling suggests that patients who remain attack-free for six months on lanadelumab every two weeks may consider decreasing to an every four week dosing schedule. We modeled this reduced dosing frequency among all attack-free patients taking lanadelumab every two weeks, and found that at least 75% of patients would need to switch to every four week dosing for lanadelumab to be cost-effective at the \$150,000 willingness to pay threshold. Furthermore, lanadelumab would become dominant (i.e., lower costs and higher QALYs) over no prophylaxis from both the health system and modified societal perspectives if approximately 87% of patients who are attack free on every two week dosing switched to every four week dosing.

Threshold Analyses

We found that relatively small changes in the baseline monthly attack rate were required to reach the cost-effectiveness thresholds of \$50,000 to \$500,000 per QALY (Table ES7). Similarly, we calculated the threshold prices corresponding to incremental cost-effectiveness ratios of \$50,000 to \$500,000 per QALY and found that both Cinryze and lanadelumab would need to be priced substantially lower than the current net price per package to reach cost-effectiveness thresholds (Table ES8).

Table ES7. Results of Threshold Analysis on Baseline Attack Rate

	Attack Rate to Achieve \$50,000 per QALY	Attack Rate to Achieve \$100,000 per QALY	Attack Rate to Achieve \$150,000 per QALY	Attack Rate to Achieve \$250,000 per QALY	Attack Rate to Achieve \$500,000 per QALY
Cinryze	5.99	5.95	5.92	5.84	5.66
Haegarda	3.52	3.49	3.47	3.43	3.32
Lanadelumab	3.87	3.85	3.82	3.77	3.65

QALY: quality-adjusted life year

Table ES8. Resulting Prices for Long-Term Prophylaxis Medications to Reach Cost per QALY Thresholds

	List price	Net Price per Package	Price to Achieve \$50,000 per QALY	Price to Achieve \$100,000 per QALY	Price to Achieve \$150,000 per QALY	Price to Achieve \$200,000 per QALY	Price to Achieve \$300,000 per QALY	Price to Achieve \$500,000 per QALY
Cinryze (500 IU)	\$2,759	\$2,012	\$1,096	\$1,104	\$1,112	\$1,120	\$1,137	\$1,169
Haegarda (2,000 IU)	\$1,880	\$1,393	\$1,341	\$1,351	\$1,360	\$1,369	\$1,388	\$1,425
Lanadelumab (300 mg)	\$22,070	\$16,520	\$14,431	\$14,530	\$14,628	\$14,727	\$14,924	\$15,319

QALY: quality-adjusted life year

Model Validation

Model validation followed standard practices in the field. We tested all mathematical functions in the model to ensure they were consistent with the report (and supplemental Appendix materials). We also conducted sensitivity analyses with null and maximum input values. The model was producing findings consistent with expectations. Further, independent modelers tested the mathematical functions in the model as well as the specific inputs and corresponding outputs.

Summary and Comment

Prophylactic treatment for patients with HAE 1/2 improves health outcomes by reducing the number of acute attacks. In base case analyses, Cinryze (\$5,954,000 per QALY), Haegarda (\$328,000 per QALY), and lanadelumab (\$1,108,000 per QALY) all far exceeded cost-effectiveness thresholds of \$100,000 to \$150,000 per QALY.

The overall cost-effectiveness of prophylactic treatment is dependent upon the balance between the costs of therapies used for prophylaxis and the costs of on-demand treatment that can be avoided by reducing acute attacks. This effect is magnified by the high costs of both prophylactic and on-demand therapies and the fact that patients receive treatment over their remaining lifetime. The economic modeling results are therefore highly sensitive to assumptions made about variables such as the baseline rate of acute attacks and the likelihood that patients will switch dosing schedules over time for prophylactic therapy. For example, the cost-effectiveness of prophylactic treatment with Haegarda varied from \$50,000 per QALY for patients with 3.52 acute attacks per month to \$500,000 per QALY for patients with a baseline of 3.32 attacks per month. Similarly, despite a baseline cost-effectiveness for lanadelumab of more than \$1 million per QALY when administered every two weeks, if 86.7% of patients who are attack free for six months switch to every four week dosing, which the FDA label says “may be considered,” then prophylactic treatment with lanadelumab becomes dominant (improves outcomes and saves costs). Cinryze, however, appeared unlikely to be cost-effective at usual thresholds across a range of assumptions.

There are several important limitations to our analysis. Our estimates of long-term comparative clinical effectiveness of prophylaxis are uncertain due to a lack of data on the natural history of attack rates over patients’ lifetimes and by the small sample sizes and the short duration of the available clinical trials. Our analysis was also limited by inadequate data and a lack of clinical guideline standards by which to estimate the baseline attack rates for patient populations that will be considered for prophylactic therapy. Our base-case analysis was able to capture the potential of prophylaxis to reduce the severity of subsequent attacks only for Haegarda, because similar data were not available for the Cinryze or lanadelumab. We therefore ran scenario analyses that assumed Cinryze and lanadelumab had a similar impact on severity. The analysis revealed only modest impacts on the overall results. Finally, because US-specific data on utilities and HAE mortality were not available, we used estimates from European studies.

In summary, at current drug prices, prophylactic treatment for HAE 1/2 does not meet traditional cost-effectiveness thresholds within the health care system perspective under our base case assumptions. However, there is significant uncertainty in key model assumptions, demonstrated by widely varying cost-effectiveness findings in univariate and multivariable sensitivity analyses.

Potential Other Benefits and Contextual Considerations

Our reviews seek to provide information on potential other benefits offered by the intervention to the individual patient, caregivers, the delivery system, other patients, or the public that would not have been considered as part of the evidence on comparative clinical effectiveness. These elements are listed in the table below.

Potential Other Benefits

Table ES9. Potential Other Benefits

Other Benefits	Description
This intervention offers reduced complexity that will significantly improve patient outcomes.	The subcutaneous options for prophylaxis will decrease the burden and complexity of administration (including fewer complications due to repeated infusion therapy or use of ports), decrease administration costs, and increase convenience to patients. The biweekly or monthly dosing of lanadelumab will offer greater convenience to patients.
This intervention will reduce important health disparities across racial, ethnic, gender, socio-economic, or regional categories.	In areas where access to health care or access to on-demand therapy is limited, long-term prophylactic therapy could be potentially life-saving.
This intervention will significantly reduce caregiver or broader family burden.	The reduction in HAE attacks from long-term prophylaxis will decrease caregiver physical and emotional burden. Subcutaneous injections may decrease caregiver burden.
This intervention offers a novel mechanism of action or approach that will allow successful treatment of many patients for whom other available treatments have failed.	Lanadelumab offers a novel mechanism of action from C1-INHs that may benefit patients whose disease is not optimally controlled on C1-INH.
This intervention will have a significant impact on improving return to work and/or overall productivity.	The decrease in HAE attack rates with long-term prophylactic therapy is likely to decrease anxiety and stress about future attacks, allow for less restrictions on work and leisure activities, improve work or school productivity, and improve career advancement and educational attainment.
This intervention will have a significant positive impact outside of the family, including on schools and/or communities.	Reduction in HAE attacks may decrease absenteeism and impairment at work or school for caregivers, improving their educational achievement or career advancement. Schools and communities are likely to benefit from such improvements.

This intervention will have a significant impact on the entire “infrastructure” of care, including effects on screening for affected patients, on the sensitization of clinicians, and on the dissemination of understanding about the condition, that may revolutionize how patients are cared for in many ways that extend beyond the treatment itself.	New treatment options increase the visibility of HAE to clinicians, heightening their awareness of the disease, which may in turn lead to earlier diagnosis, fewer inappropriate therapies (e.g., unnecessary surgery for abdominal pain), and more appropriate treatment in the emergency department, saving patients years of suffering.
Other important benefits or disadvantages that should have an important role in judgments of the value of this intervention.	Patients report that the ability to self-administer therapy may lead to increased feelings of control over the disease, a greater ability to lead a normal life, and decreased burden on caregivers.

Contextual Considerations

Table ES10. Contextual Considerations

Contextual Consideration	Description
This intervention is intended for the care of individuals with a condition of particularly high severity in terms of impact on length of life and/or quality of life.	HAE is a potentially life-threatening disease that results in substantial decrement in quality of life due to disability from attacks as well as psychological effects of the uncertainty regarding the onset and pattern of attacks.
This intervention is intended for the care of individuals with a condition that represents a particularly high lifetime burden of illness.	Patients with HAE can have frequent, debilitating attacks that affect their quality of life over their lifetime.
This intervention is the first to offer any improvement for patients with this condition.	N/A
Compared to on-demand treatment there is significant uncertainty about the long-term risk of serious side effects of this intervention.	There are significant uncertainties about the long-term safety and efficacy of lanadelumab, a monoclonal antibody. New biologic therapies frequently are found to have safety concerns that were not detected in pre-approval trials.
Compared to on-demand treatment there is significant uncertainty about the magnitude or durability of the long-term benefits of this intervention.	The durability of effect from long-term prophylaxis has not been established; clinical trials ranged from 4-26 weeks of follow-up.
There are additional contextual considerations that should have an important role in judgments of the value of this intervention.	None.

Value-Based Benchmark Prices

Annual value-based benchmark prices of the drugs for prophylactic treatment of HAE 1/2 patients are presented in Table ES11. For Cinryze, price discounts of approximately 60% from the list price (WAC) would be required to reach the \$100,000 to \$150,000 per QALY threshold prices. Discounts

from the list price to reach the \$100,000 to \$150,000 per QALY threshold prices would be approximately 28% for Haegarda, and approximately 34% for lanadelumab.

Table ES11. Value-Based Benchmark Prices for HAE 1/2 Prophylactic Therapies

	List Price	Net Price	Price to Achieve \$100,000 per QALY	Price to Achieve \$150,000 per QALY	Discount from List Price to Reach Threshold Prices
Cinryze*	\$539,670	\$401,512	\$215,993	\$217,577	59.7% to 60.0%
Haegarda	\$509,792	\$377,786	\$366,280	\$368,802	27.7% to 28.2%
Lanadelumab	\$565,557	\$423,344	\$372,327	\$374,857	33.7% to 34.2%

QALY: quality-adjusted life year

*Weighted average of 95.2% self-administered and 4.8% physician-administered.

Potential Budget Impact

We used the cost-effectiveness model to estimate the potential total budgetary impact of lanadelumab in HAE 1/2 patients in the US, at the annual wholesale acquisition cost (WAC) of \$565,557, the net price of \$423,344, and the cost-effectiveness threshold prices at \$50,000, \$100,000, and \$150,000 per QALY.

The potential budget impact analysis included the population eligible for treatment: patients in the US with HAE 1/2 who are candidates for long-term prophylactic treatment. To estimate the size of the potential candidate population, we applied an estimate of one per 50,000 individuals with HAE 1/2⁴ to the size of the US population³³ to obtain an estimated US prevalence of 6,690 individuals. As not all patients with HAE 1/2 are considered candidates for long-term prophylactic treatment, we assumed that one-third were eligible for prophylaxis, resulting in approximately 2,230 patients, or 446 patients per year assuming equal uptake over five years. A detailed description of our methods in estimating budget impact, including the determination of eligible population, is available in Section 7.2 of the report.

Table ES12 illustrates the per-patient budget impact calculations for lanadelumab in eligible patients with HAE compared to a 49%/49%/2% mix of Haegarda/Cinryze/no long-term prophylaxis. The average potential budgetary impact at WAC was approximately \$96,100 per patient but was cost-saving at the net price and at the prices to reach \$150,000, \$100,000, and \$50,000 per QALY in this population (\$374,857, \$372,327, and \$369,798 per year, respectively).

Table ES12. Per-Patient Budget Impact Calculations Over a Five-Year Time Horizon for Lanadelumab in Eligible Patients with HAE

Average Annual per Patient Budget Impact					
	WAC	Net Price	\$150,000/QALY	\$100,000/QALY	\$50,000/QALY
Lanadelumab	\$620,338	\$478,464	\$430,092	\$427,569	\$425,045
Haegarda/Cinryze/No Long-Term Prophylaxis (49%/49%/2%)	\$524,192				
Difference	\$96,145	-\$45,729*	-\$94,100*	-\$96,624*	-\$99,147*

QALY: quality-adjusted life year

*Cost-saving.

The annual potential budgetary impact of treating the entire eligible population with lanadelumab did not exceed the \$991 million ICER budget impact threshold, reaching only 13% of the threshold at current WAC, and being cost-saving at other price levels, mainly due to the higher costs associated with prophylactic treatment with Cinryze in the comparator arm.

We also conducted a scenario analysis to explore the budget impact when a patient using no long-term prophylaxis switched to lanadelumab. Under this scenario, the average potential budgetary impacts when using the WAC and net price of lanadelumab were additional per-patient costs of approximately \$192,200 and \$50,360, respectively. The budget impact would be approximately \$1,980 per patient at the price to achieve \$150,000 per QALY, and cost-saving by approximately \$3,100 and \$540 per patient at the prices to achieve \$50,000 and \$100,000 per QALY, respectively.

California Technology Assessment Forum Votes

The California Technology Assessment Forum (CTAF) Panel deliberated on key questions raised by ICER’s report at a public meeting on October 25, 2018 in Oakland, California. The results of these votes are presented below, and additional information on the deliberation surrounding the votes can be found in the full report.

Patient Population for all questions: Patients with Type 1 and Type 2 Hereditary Angioedema (HAE 1/2) who are eligible for long-term prophylactic therapy.

- 1. Is the evidence adequate to distinguish the net health benefits between the C1-INHs Cinryze and Haegarda for long-term prophylactic therapy for HAE 1/2?**

Yes: 1 vote	No: 14 votes
-------------	--------------

2. Is the evidence adequate to demonstrate that the net health benefits of long-term prophylaxis with C1-INH for HAE 1/2 are superior to on-demand therapy only?

Yes: 14 votes	No: 1 vote
---------------	------------

3. Is the evidence adequate to demonstrate that the net health benefits of long-term prophylaxis with lanadelumab for HAE 1/2 are superior to on-demand therapy only?

Yes: 4 votes	No: 11 votes
--------------	--------------

4. Does treating HAE 1/2 patients with long-term prophylactic therapy offer one or more of the following potential “other benefits” versus on-demand treatment?

<i>Haegarda</i> offers reduced complexity that will significantly improve patient outcomes.	15/15
<i>Lanadelumab</i> offers reduced complexity that will significantly improve patient outcomes.	13/15
This intervention will reduce important health disparities across racial, ethnic, gender, socioeconomic, or regional categories.	0/15
This intervention will significantly reduce caregiver or broader family burden.	13/15
<i>Lanadelumab</i> offers a novel mechanism of action or approach that will allow successful treatment of many patients for whom other available treatments have failed.	7/15
This intervention will have a significant impact on improving patients’/caregivers’ ability to return to work or school and/or their overall productivity.	13/15
This intervention will have a significant positive impact outside the family, including on schools and/or communities.	4/15
This intervention will have a significant impact on the entire “infrastructure” of care, including effects on screening for affected patients, on the sensitization of clinicians, and on the dissemination of understanding about the condition, that may revolutionize how patients are cared for in many ways that extend beyond the treatment itself.	2/15
There are other important benefits or disadvantages that should have an important role in judgments of the value of this intervention.	2/15

5. Are any of the following contextual considerations important in assessing the long-term value for money of long-term prophylactic therapy for HAE 1/2?

This intervention is intended for the care of individuals with a condition of particularly high severity in terms of impact on length of life and/or quality of life.	11/15
This intervention is intended for the care of individuals with a condition that represents a particularly high lifetime burden of illness.	10/15
This intervention is the first to offer any improvement for patients with this condition.	0/15
Compared to on-demand treatment only, there is significant uncertainty about the long-term risk of serious side effects of using C1-INHs .	5/15
Compared to on-demand treatment only, there is significant uncertainty about the long-term risk of serious side effects of using lanadelumab .	14/15
Compared to on-demand treatment only, there is significant uncertainty about the magnitude or durability of the long-term benefits of using C1-INHs .	9/15
Compared to on-demand treatment only, there is significant uncertainty about the magnitude or durability of the long-term benefits of using lanadelumab .	15/15
There are additional contextual considerations that should have an important role in judgments of the value of this intervention.	0/15

6. Given the available evidence on comparative effectiveness and incremental cost effectiveness, and considering other benefits, disadvantages, and contextual considerations, what is the long-term value for money of long-term prophylaxis of HAE with Cinryze versus on-demand therapy?

Low: 14 votes	Intermediate: 1 vote	High: 0 votes
---------------	----------------------	---------------

7. Given the available evidence on comparative effectiveness and incremental cost effectiveness, and considering other benefits, disadvantages, and contextual considerations, what is the long-term value for money of long-term prophylaxis of HAE with Haegarda versus on-demand therapy?

Low: 7 votes	Intermediate: 7 votes	High: 1 vote
--------------	-----------------------	--------------

8. Given the available evidence on comparative effectiveness and incremental cost effectiveness, and considering other benefits, disadvantages, and contextual considerations, what is the long-term value for money of long-term prophylaxis of HAE with lanadelumab versus on-demand therapy?

Low: 13 votes	Intermediate: 2 votes	High: 0 vote
---------------	-----------------------	--------------

Key Policy Implications

Following its deliberation on the evidence, the CTAF Panel engaged in a moderated discussion with a policy roundtable about how best to apply the evidence on C1-INHs and lanadelumab for long-term prophylaxis of HAE 1/2 to policy and practice. The policy roundtable members included one patient representative, one clinical expert, a payer, and a representative from a manufacturer. The discussion reflected multiple perspectives and opinions, and therefore, none of the statements below should be taken as a consensus view held by all participants. A summary of key policy implications is presented below, organized by audience, and additional information can be found in Section 8 of the full report.

Payers

1. Payers seeking to negotiate better prices may consider giving all market share to subcutaneous treatments, due to their decreased burden complexity of administration.
2. Prior authorization criteria should be based on clinical evidence with input from clinical experts and patient groups. Options for specific elements of coverage criteria within insurance coverage policy are discussed below:

Potential Patient Eligibility Criteria

Diagnostic Criteria

- a. Patients with HAE 1/2 confirmed by laboratory diagnosis.* This would include measuring C1-INH, C4 protein levels, C1-INH functional levels, and C1q.
- b. Physician attestation based on family history or history of response to on-demand treatment.*

Indication for Long-Term Prophylaxis

- a. Attack frequency and severity.* There is currently no clinical consensus regarding disease or attack characteristics that would indicate a need for long-term prophylaxis; however, clinical guidelines recommend that the impact of attack frequency and severity on quality of life be incorporated into the decision-making process for long-term prophylaxis. A threshold of ≥ 2 attacks per month were used in clinical trials, but higher thresholds may improve the cost-effectiveness of treatments.
- b. Use of on-demand treatment.* Frequency or amount of on-demand treatment could be used as proxies for attack severity.

Potential Provider Criteria

- a. A requirement for specialty diagnosis for coverage of therapy.*

Potential Limitation on Duration or Amount of Medication

a. Coverage caps based on weight-based dosing. This is particularly relevant for Haegarda, which utilizes a weight-based dosing scheme. Cinryze and lanadelumab are typically administered in fixed doses.

3. Given that the cost effectiveness of lanadelumab can be vastly improved by switching attack-free patients from every two week to every four week dosing, payers should work with clinicians to encourage trial periods of the less frequent dosing if patients are attack-free after six months of therapy.

Manufacturers

4. Innovation that addresses unmet clinical need and produces overall cost savings in the health system is ideal and should be encouraged. However, treatments like Haegarda and lanadelumab can appear cost-saving at a very high price only because of the extremely high annual costs for on-demand treatment of many patients with HAE 1/2. In these situations, reasonable value-based pricing for new treatments requires consideration of a new paradigm for “shared savings” between innovators and society.

5. Manufacturers should ensure that developmental trials consider, whenever possible, adaptive designs that incorporate head-to-head comparison of drugs and standardized, universally recognized quality of life measures to capture a more comprehensive response to treatment. Such information can be then used in to improve patient/provider decision-making and payer evaluation of value.

Providers and Specialty Societies

6. There are currently no consensus criteria on when to consider starting long-term prophylaxis for patients with HAE 1/2. Specialists involved in the care of patients with HAE 1/2 should convene and work with patients to develop a consensus statement to guide policymakers and payers on the appropriate use of long-term prophylaxis for patients with HAE 1/2.

1. Introduction

1.1 Background

Background

Hereditary angioedema (HAE) is a rare autosomal dominant genetic disorder characterized by recurrent episodes of tissue swelling in various parts of the body, including the face, hands, feet, airways, and intestinal tract.¹ The disease affects approximately 1 in 50,000 individuals, with males and females equally affected, and has been reported in all races and ethnicities.^{4,5} Attacks can happen at any age after birth, and the mean age for a first attack is 10 years.³⁴ Diagnosis of HAE can be challenging, particularly in patients who do not have a family history of the disease. Patients report having an average delay of 8 to 10 years from the onset of symptoms until diagnosis.³⁵

Most cases of HAE are caused by mutations in the gene that codes for C1 inhibitor (C1 esterase inhibitor; C1-INH).² The mutations lead to either deficient C1-INH levels (HAE Type 1) or dysfunctional C1-INH (HAE Type 2). C1-INH plays an important role in the regulation of the kallikrein-kinin system, preventing the accumulation of bradykinin, which is a potent vasodilator. It is the dysfunction of the kallikrein-kinin pathway that leads to the development of HAE symptoms (Figure 1).³ During an acute attack, uncontrolled activation of factor XII and prekallikrein due to absolute or relative C1-INH deficiency leads to high levels of factor XIIa and kallikrein, which in turn results in an increase in bradykinin. High levels of bradykinin can lead to episodes of extreme dilation of blood vessels, resulting in leakage of plasma and tissue swelling. Tissue swelling can develop at any site in the body but is most commonly found under the skin (subcutaneous swelling, occurs in 91% of patients), under a mucous membrane such as in the bowel wall (submucosal swelling causing abdominal pain occurs in 74% of patients), and in the upper airway (laryngeal swelling occurring in 47% of patients).⁶ HAE Type 1 is five to six times more common than HAE Type 2.¹ Additionally, there is a third type of HAE where patients have normal C1-INH levels and function (HAE nC1-INH, also called HAE Type 3), thought to be caused by a mutation in the factor XII gene, which may also lead to elevated levels of bradykinin.³⁶ Although clinically patients with HAE Type 3 may present with similar features to patients with HAE 1 and 2, optimal treatment of HAE Type 3 has yet to be fully defined, as there are no placebo-controlled trials in this population.³⁷ Thus, our review will focus on the treatment of the two more common types of HAE.

Figure 1.1 Pathogenesis of HAE

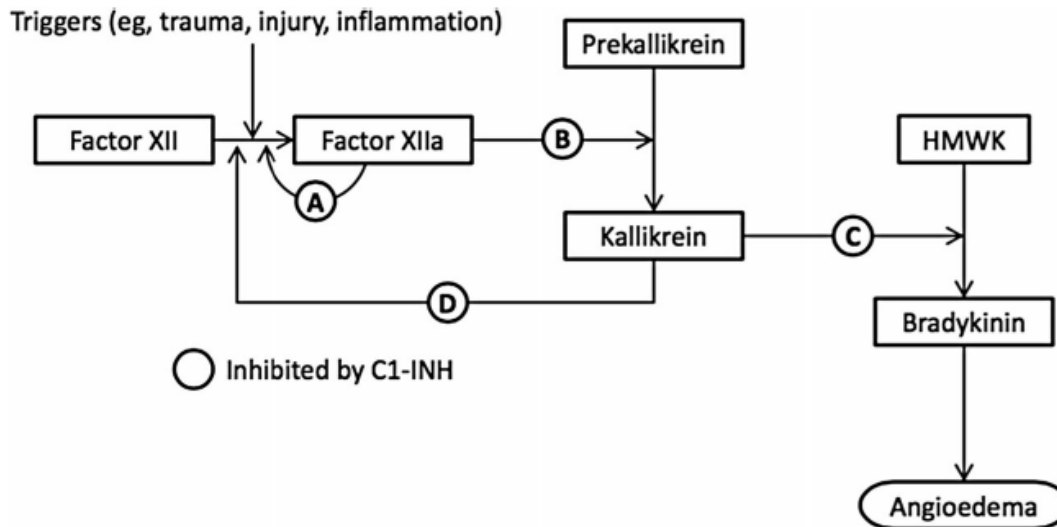

The figure shows the kallikrein-kinin pathway and the role of C1-INH in preventing overproduction of bradykinin. C1-INH is an important regulator in the cascade at points A-D. HMWK = high-molecular-weight-kininogen. See the corresponding citation for more information about this figure, which was first published in *Allergy & Immunology* in June 2018.³

HAE attacks can involve one or more sites on the body, and range in severity from mild to severe. Potential triggers for HAE attacks include mechanical trauma, mental stress, respiratory infections, and certain medications such as oral contraceptives and angiotensin-converting enzyme (ACE) inhibitors. However, many attacks occur without a known trigger. Episodes are usually self-limited, lasting on average between two to five days.⁸ Laryngeal edema, or swelling of the airways during an attack, is potentially life-threatening, with a 30% risk of death due to asphyxiation if untreated;⁷ however, with treatment, death is rare. Attack frequency is variable and can range from rare to once every three days.^{1,7} A survey of 143 US HAE patients found that 25% of patients reported having one or more attacks per week, 48% reported having one or more attacks per month, and 26% reported having fewer than one attack per month.⁹ However, this survey was retrospective, and attacks were self-reported. In a prospective cohort study of 227 Italian patients reporting data based on attack diaries, 3% of patients reported having more than 30 attacks per year, 18% of patients reported 11-30 attacks per year, and 79% of patients reported 10 or less attacks per year.¹⁰ The unpredictability of attack frequency and severity can result in significant anxiety for patients.²²

Management of HAE

Management of HAE consists of avoidance of triggers and drug treatment. Medications for HAE can be categorized into on-demand therapies, which are taken during an attack; short-term prophylaxis (i.e., premedication before a known precipitant for an attack, sometimes referred to as periprocedural prophylaxis); and long-term prophylaxis of attacks. International guidelines and consensus documents recommend that all attacks be considered for treatment, and that long-term

prophylaxis be considered in all patients for whom on-demand therapy is insufficient to minimize effects of the disease.^{13,19,38,39} Treatment for HAE is costly; medications for on-demand therapy range in cost from \$5,000 to more than \$12,000 per attack treated in the US, and treatment with medications for long-term prophylaxis may cost upwards of \$500,000 annually.¹¹

On-Demand Treatment for Acute Attacks

The goal of treatment for acute attacks is to minimize the severity of angioedema symptoms and resolve symptoms as quickly as possible. Treatments fall into three categories: C1-INH concentrates (plasma-derived [Berinert[®], CSL Behring GmbH] or recombinant [Ruconest[®], Pharming Group N.V.]), kallikrein inhibitor (ecallantide [Kalbitor[®], Shire Plc]), and bradykinin receptor antagonist (icatibant [Firazyr[®], Shire Plc]). Since treatment during an attack is effective in shortening attack duration,^{14,40,41} guidelines recommend that all attacks be considered for treatment.^{13,42}

Medications for acute treatment are delivered either via intravenous infusion or subcutaneous injection, and home and/or self-administration are preferred due to the unpredictability of attacks. Home administration of medication is associated with a reduction in time to symptom resolution, morbidity, mortality and treatment costs compared with administration in a clinic or hospital.¹²⁻¹⁵ Data from a 2013 survey of US physicians suggests that the majority of infusions are delivered in the home setting, either by patient self-administration or by a home nurse.¹⁷ Patient surveys further suggest that around 95% of patients have access to on-demand therapy at home,¹⁶ and that self-administration is associated with an improved quality of life due to the ability to more rapidly treat attacks, leading to shorter, less severe attacks and minimizing disruption to the patient's life.^{13,43} In a small minority of patients (around 5%) home treatment fails and there is a need to seek care in an emergency department for rebound symptoms.²¹

Short-Term Prophylaxis

To prevent potentially fatal laryngeal edema, clinical practice guidelines recommend short-term prophylaxis for any medical, surgical, or dental procedure that may trigger an attack, particularly those that involve manipulation of the airways.^{13,42} Medications for short-term prophylaxis are the same as those used for on-demand treatment.

Long-Term Prophylaxis

Long-term prophylaxis refers to the routine use of medication to reduce disease burden (i.e., prevent or reduce the frequency and severity of HAE attacks). Due to the unpredictability of HAE attacks and their potential detrimental effect on quality of life, guidelines from multiple organizations recommend individualized decisions between patients and physicians with regard to starting long-term prophylaxis.^{13,19,20} Factors that may play a role in the decision to initiate prophylaxis include overall disease burden (e.g., attack frequency and severity), impact of attacks on patient's quality of life (e.g., anxiety, depression, work or educational disruption, and ability to

perform activities of daily living), comorbidities, access to on-demand therapy and emergency medical care, and patient preference.³ In particular, prophylaxis should be considered for patients who will participate in activities associated with increased disease activity and for all severely symptomatic HAE patients.^{13,42} Since long-term prophylaxis could involve self-administration of intravenous or subcutaneous medications on a regular basis, there may be barriers to successful long-term treatment, including difficulty with self-administration and cost.⁴⁴⁻⁴⁶ Treatment may or may not need to be lifelong, depending on the patient's clinical course.

Three classes of drugs – C1-INHs, 17 alpha-alkylated androgens, and antifibrinolytics – are currently being used for long-term prophylaxis of HAE 1/2, and a monoclonal antibody, lanadelumab, was recently approved in the US for this indication. This review focuses on C1-INHs and lanadelumab (Table 1.1), as androgens are considered second-line therapy for long-term prophylaxis and antifibrinolytics are not recommended unless C1-INHs are not available and androgens are contraindicated.¹³

Table 1.1. Treatments for Long-Term Prophylaxis for HAE 1/2 Discussed in Report

Drug (Brand Name)	Manufacturer	US FDA Approval Date	Mechanism of Action	Method of Delivery	Approved Population
Plasma-Derived C1-INH (Cinryze)	Shire Plc	2008	C1-INH replacement	Intravenous	Ages 6 and older
Plasma-Derived C1-INH (Haegarda)	CSL Behring GmbH	2017	C1-INH replacement	Subcutaneous	Ages 12 and older
Lanadelumab (Takhzyro)	Shire Plc	2018	Kallikrein inhibitor	Subcutaneous	Ages 12 and older

C1 Inhibitors

C1-INHs can be used for long-term prophylaxis for HAE. Until recently, the only human plasma-derived C1-INH approved for long-term prophylaxis for adults and adolescents 12 years or older was Cinryze, which was approved in the US in 2008.⁴⁷ Cinryze requires intravenous administration every three to four days, and some patients may need higher doses to achieve a reduction in attacks. In June 2018, Cinryze was also approved for long-term prophylaxis in children ages 6 to 12. Ruconest, a recombinant form of C1-INH, was discussed in the draft version of this report, as it was under consideration by the US Food and Drug Administration (FDA) for long-term prophylaxis. However, the intravenous formulation is no longer under consideration for this indication; therefore, all discussion concerning Ruconest for long-term prophylaxis has now been removed.²⁵

Long-term use of intravenous infusions can lead to scarring of the veins, making future infusions more difficult; if infusion ports are required, infectious and thrombotic complications can occur as well. Thus, there has been interest in developing alternate methods of C1-INH delivery. In 2017, a

subcutaneous form of human-derived C1-INH, Haegarda® (CSL Behring GmbH), was approved for long-term prophylaxis for adults and adolescents.⁴⁸ The medication is taken twice weekly as a subcutaneous injection.

Lanadelumab

Lanadelumab (Shire Plc) is a newly developed monoclonal antibody targeting plasma kallikrein that was approved in August 2018 for long-term prophylaxis in HAE patients. By inhibiting the activity of kallikrein, this medication prevents the cleavage of high molecular weight kininogen and the release of bradykinin that leads to symptomatic HAE attacks.³⁰ It is designed to be administered subcutaneously once every two or four weeks.

Future Therapies

Treatments for HAE 1/2 have primarily focused on replacement of endogenous C1-INH. However, there are various other targets for inhibition of bradykinin formation that are candidates for drug development to prevent HAE attacks. Drugs targeting the inhibition of kallikrein via small molecules are under development (BCX7353, BioCryst Pharmaceuticals, Inc.).⁴⁹ Other potential drug targets include inhibiting factor XII (e.g., with a blocking antibody), inhibiting the cleavage of prekallikrein, and blocking the bradykinin-B2-receptor.⁴⁹ Additionally, as HAE 1/2 is caused by mutations in a gene coding for C1-INH, gene therapy may be a possibility in the future.

1.2 Scope of the Assessment

Overview

This report assesses both the comparative clinical effectiveness and economic impacts of long-term prophylaxis with C1-INHs and lanadelumab for patients with HAE 1/2. The assessment aims to systematically evaluate the existing evidence, taking uncertainty and patient-centered considerations into account. To that aim, the assessment is informed by two research components, a systematic review of the existing evidence and an economic evaluation, developed with input from a diverse group of stakeholders, including patients, clinicians, researchers, and manufacturers of the agents of focus in this review. Below, we present the review's scope in terms of the research questions, PICOTS (Population, Interventions, Comparisons, Outcomes, Timing, Setting, and Study Design) elements, and an analytic framework diagram.

Research Question

The following research questions were developed with input from clinical experts, patients, and other stakeholders:

- In patients with HAE 1/2, what is the comparative efficacy, safety, effectiveness, and economic impact of long-term prophylaxis with Cinryze, Haegarda, or lanadelumab versus no long-term prophylaxis?
- In patients with HAE 1/2, what is the comparative efficacy, safety, effectiveness, and economic impact among the different drugs for long-term prophylaxis (Cinryze, Haegarda, and lanadelumab)?

Populations

The review focused on patients with HAE 1/2.

Interventions

The following therapies were evaluated when used as prophylaxis:

- Intravenous plasma-derived C1-inhibitor (Cinryze)
- Subcutaneous plasma-derived C1-inhibitor (Haegarda)
- Lanadelumab

Comparators

We compared all the agents to no long-term prophylaxis. We assumed that all patients, whether or not they were receiving long-term prophylaxis, were treated for acute attacks. We considered comparing the agents to each other using network meta-analysis; however, available data did not permit these comparisons.

Outcomes

Table 1.2. Key Outcomes and Harms

Outcomes	Key Harms
HAE attacks	Thrombotic events
Quality of life	Injection site or infusion reactions
Impact of attacks on school or work	Complications related to having an infusion port
Depression and anxiety	Headache
Use of rescue medication	Hypersensitivity
Emergency department visits	Nasopharyngitis or upper respiratory tract infection
Mortality	Nausea or vomiting
	Dizziness
	Transmission of infectious disease for plasma-derived products (e.g., hepatitis, Creutzfeldt-Jakob Disease)
	Adverse events leading to discontinuation of therapy

Timing

Evidence on intervention effectiveness and harms were derived from studies of any duration.

Settings

All relevant settings were considered, with a focus on outpatient settings in the United States.

Analytic Framework

The analytic framework for this assessment is depicted in Figure 1.2.

Figure 1.2. Analytic Framework

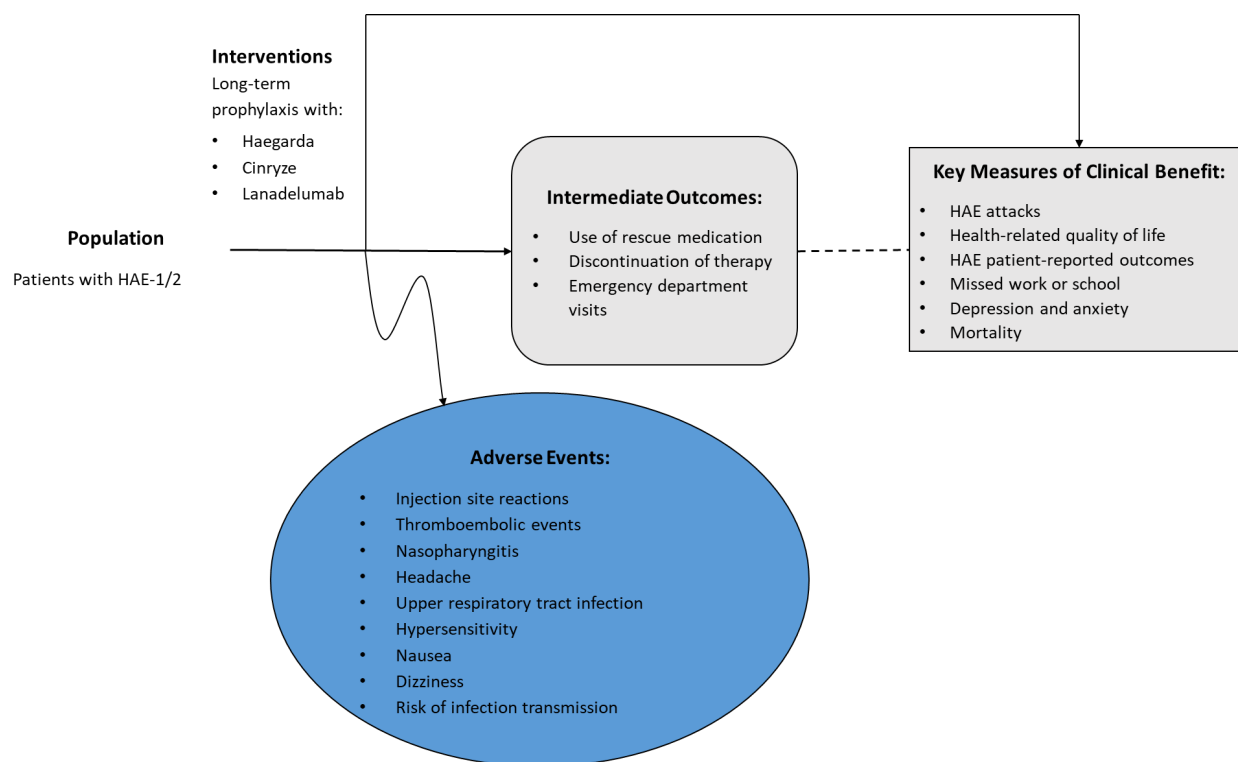

The diagram begins with the population of interest on the left. Actions, such as treatment, are depicted with solid arrows which link the population to outcomes. For example, a treatment may be associated with specific health outcomes. Outcomes are listed in the shaded boxes; those within the rounded boxes are intermediate outcomes (e.g., use of rescue medication), and those within the squared-off boxes are key measures of benefit (e.g., HAE attacks). The key measures of benefit are linked to intermediate outcomes via a dashed line, as the relationship between these two types of outcomes may not always be validated. Curved arrows lead to the adverse events of treatment which are listed within the blue ellipsis.⁵⁰

1.3 Definitions

Attack: This term is used to describe an acute episode of angioedema. In patients with HAE, the number and severity of attacks are key criteria for determining eligibility for long-term prophylaxis.

Plasma-derived C1 inhibitor: This medication is prepared by separating the protein of interest (in this case C1-INH) from human plasma, screening for the presence of viruses, and then purifying the remaining protein. There is a theoretical risk of developing antibodies to plasma-derived medications, transmission of human viruses, and the potential for supply issues due to the fact that production depends both on an adequate supply of human plasma and good manufacturing practices to purify the human plasma. For example, there was a shortage of Cinryze in 2017 due to manufacturing issues.⁵¹

Recombinant C1 inhibitor: This medication is derived from non-human plasma sources. The main advantages of recombinant C1-INH compared with plasma-derived C1-INH are the reliable supply chain, lack of risk of virus transmission, and the ability to scale production based on needs.

Quality of life scales

- **EuroQoL-5D (EQ-5D):** A standardized quality of life questionnaire developed by the EuroQoL group and frequently used as a measure of quality of life in clinical trials. The questionnaire asks about patient's self-rated health in five areas: mobility, self-care, usual activities, pain/discomfort, and anxiety/depression.
- **Short Form-36 (SF-36):** A standardized, patient-reported quality of life questionnaire developed by RAND Health. The questionnaire is used in studies examining patients' quality of life and consists of 36 questions asking about mental and physical health.
- **Hereditary Angioedema Quality of Life Questionnaire (HAE-QoL):** This is a recently developed patient-reported quality of life questionnaire specific to HAE patients. The HAE-QoL addresses seven relevant quality of life domains for adult patients with HAE: treatment difficulties, physical functioning and health, disease-related stigma, emotional role and social functioning, concern about offspring, perceived control over illness, and mental health. It has not been used in any trials to date.
- **Angioedema Quality of Life Questionnaire (AE-QoL):** A patient-reported tool used to assess health-related quality of life in patients with recurrent angioedema. It comprises of 17 items used to calculate four domain scores (functioning, fatigue/mood, fear/shame, and nutrition); higher scores reflect greater impairment in health-related quality of life.
- **Hospital Anxiety and Depression Scale (HADS):** The HADS is a 14-item self-assessment form that detects anxiety and depression. Seven items are related to anxiety and seven are related to depression. Each item is scored on a scale of 0 to 3 (3 indicates higher symptom frequencies) to generate anxiety or depression scores of 0 to 21. A score above 8 is a

generally-used cutoff indicating a possible diagnosis of anxiety or depression.⁵² The HADS is used for screening only and does not represent a clinical diagnosis.

- **Work Productivity and Activity Impairment (WPAI):** The WPAI is a self-administered instrument used to assess the impact of disease on productivity.

1.4 Insights Gained from Discussions with Patients and Patient Groups

HAE can have significant effects on patients' quality of life. Attacks can be debilitating and life-threatening, depending on the site and severity of the attack. Due to the unpredictability of attacks and the variability in attack frequency and severity, some patients describe high burdens from HAE on their daily lives including anxiety about potential attacks, the need to carry on-demand therapy, and the need to consider whether adequate medical care is accessible when planning activities. Patients also report that due to the unpredictability of attacks and the variable disability attacks cause, HAE can have a significant effect on work or school in terms of missed days for attacks and can hinder career or educational advancement. HAE not only affects patients but their caregivers as well. Caregivers, often parents of children with HAE, may also need to take time off work to care for an HAE patient.

Studies have shown that almost three-quarters of HAE patients noted that the disease had a significant impact on their quality of life, including anxiety (15% of patients) and depression (almost 40% of patients) related to their ability to carry out daily activities, fear of attacks, and concerns about transmission of the condition to their children.²¹⁻²³ Quality of life appears to be worse in patients reporting more than five attacks per year.²¹ Studies that have characterized patients' quality of life using validated scales such as the SF-36 and EQ-5D have shown significant decreases in quality of life scores similar to those of patients with Crohn's disease or severe asthma.²⁴

Insurance coverage issues for HAE medications were mentioned by patients as a barrier to obtaining treatment. Patients report needing to spend time navigating the insurance system and also needing to rely on manufacturer programs to ensure access to treatment while dealing with insurance issues. Anecdotally, some patients reported difficulty attaining insurance coverage for simultaneous on-demand and long-term prophylactic therapy due to some insurers' requirement that patients be symptomatic to obtain on-demand therapy. Finally, given the variation in patient response to medications, patient groups worried that any restrictions placed on medications would adversely affect patient outcomes.

1.5 Research, Development, and Manufacturing Costs

As described in ICER's modified framework for assessing value of treatments for ultra-rare diseases, ICER invited manufacturers to submit relevant information on research, development, and manufacturing costs that may impact pricing of a drug. For this report, no manufacturer submitted information on development or production costs that they believed would be an important factor in justifying the price of their products.

1.6. Potential Cost-Saving Measures in HAE

As described in its Final Value Assessment Framework, ICER will now include in its reports information on wasteful or lower-value services in the same clinical area that could be reduced or eliminated to create headroom in health care budgets for higher-value innovative services (for more information, see <https://icer-review.org/final-vaf-2017-2019/>). ICER encouraged all stakeholders to suggest services (including treatments and mechanisms of care) currently used for people with HAE that could be reduced, eliminated, or made more efficient. We have not received any suggestions for potential cost-saving measures but continue to seek such input.

2. Summary of Coverage Policies and Clinical Guidelines

2.1 Coverage Policies

To understand the insurance landscape for long-term prophylactic therapies for HAE, we reviewed publicly-available representative coverage policies for Cinryze and Haegarda from the Centers for Medicare and Medicaid Services (CMS), California Department of Health Care Services (DHCS), and from regional and national commercial insurers (Aetna, Anthem, Cigna, UnitedHealthcare [UHC], and Health Net). We also surveyed Blue Shield of California (BSCA) but were unable to locate a policy. At the time the revised Evidence Report was published, we were unable to locate publicly-available utilization management policies for lanadelumab, which was recently approved by the FDA. UHC's HAE policy specifies that lanadelumab can be obtained under a member's pharmacy benefit, but we were unable to locate a specific, corresponding utilization management policy.⁵³ As such, the following summaries refer only to Cinryze and Haegarda unless otherwise noted. We did not survey policies for periprocedural prophylaxis or acute treatment of HAE attacks.

We were unable to locate National Coverage Determinations (NCDs) or Local Coverage Determinations (LCDs) for any of the long-term prophylactic therapies. The policy from the California DHCS pertaining to Medi-Cal notes that C1-INHs are covered.⁵⁴

All private payers require a confirmed diagnosis of HAE and most require that a patient experience a minimum number of attacks per month. Aetna specifies that the patient must have a history of at least one attack per month, whereas Cigna notes that the patient must have at least two attacks per month.^{55,56} Health Net states that the patient must experience more than one severe event per month, or be disabled for more than five days per month, or have a history of previous airway compromise.⁵⁷ Anthem's policy is broader and stipulates that the patient must have a history of moderate or severe attacks, but it does not specify the number of attacks.⁵⁸

Prior authorization requirements and quantity limits were universal across private payers. Most payers also listed similar step therapy requirements in their utilization management policies, with Aetna and UHC being the only payers with slight differences. Aetna's policy requires that patients first attempt a treatment in the 17 alpha-alkylated androgen class (e.g., danazol and stanozolol) or antifibrinolytics (e.g., aminocaproic acid and tranexamic acid), and if these treatments are ineffective, not tolerated, or contraindicated, then the patient must attempt treatment with Haegarda before Cinryze.⁵⁵ UHC allows patients to access both Cinryze and Haegarda without step therapy.^{53,59,60} Anthem, Cigna, and Health Net listed comparable step therapy requirements for Cinryze and/or Haegarda, with patients being required to first attempt treatment with a therapy in the 17 alpha-alkylated androgen class or antifibrinolytics unless contraindicated.⁵⁶⁻⁵⁸ Aetna and

Cigna stated that Cinryze, Haegarda, and other C1-INHs for prophylaxis may not be used concomitantly. UHC further specified that Cinryze not be used concomitantly with lanadelumab.^{53,55-57}

A majority of the commercial payers included in our search cover Cinryze and Haegarda for long-term prophylaxis at the highest available formulary tier. Aetna covers both therapies, but categorizes Cinryze as a non-preferred specialty drug and Haegarda as a preferred specialty drug.⁶¹ Anthem covers both Cinryze and Haegarda, with both classified as non-preferred specialty drugs.⁶² Cigna does not cover Cinryze, but covers Haegarda as a non-preferred drug.⁶³ Cinryze is excluded from UHC's formulary, but Haegarda is covered as a "mid-range cost option" on the second out of three tiers.⁶⁰ Neither Cinryze nor Haegarda were listed on Health Net's California 3-Tier with Specialty Drug List.⁶⁴

2.2 Clinical Guidelines

We reviewed guidelines on treatment for HAE issued by major US and ex-US clinical societies, working groups, and health technology assessment organizations. Many of these guidelines included recommendations on the use of on-demand therapy and short-term prophylaxis, but for the purposes of this report, we have summarized only the guidance that relate to long-term prophylaxis. At the time this report was published, we were unable to locate any recommendations that pertained to long-term prophylaxis with Haegarda or lanadelumab, as all published guidelines were developed prior to FDA approval of these medications for long-term prophylaxis for adults and adolescents.

World Allergy Organization (WAO) in conjunction with the European Academy of Allergy and Clinical Immunology (EAACI)

The International WAO/EAACI Guideline for the Management of Hereditary Angioedema—The 2017 Revision and Update (2018)⁶⁵

In their 2017 guidelines, the WAO/EAACI recommended that long-term prophylaxis be considered for all patients with severe HAE symptoms. Long-term prophylaxis should be individualized to the patient and take into consideration disease activity, frequency and severity of attacks, quality of life, access to health care and emergency resources, and adequacy of on-demand treatment. The WAO recommended the use of twice-weekly intravenous plasma-derived C1-INH as a first-line treatment, with dosing and frequency to be adjusted for optimum efficacy, as plasma-derived C1-INH was the only drug approved for long-term prophylaxis at the time of the guideline consensus conference in June 2016. Androgens are recommended as second-line treatments, but their use should be monitored closely as they can cause serious side effects and drug-drug interactions. Antifibrinolytics are not recommended for long-term prophylaxis but may be used if C1-INHs are unavailable or androgens are contraindicated.

The WAO/EAACI recommends that the patient's treatment plan and use of long-term prophylactic therapies be reviewed and evaluated at least yearly to gauge their efficacy, safety, and dosing. The authors of the guidelines emphasized that HAE attacks may still occur even with the use of long-term prophylaxis and recommended that all patients on long-term prophylaxis also have a supply of on-demand medication, such as C1-INH concentrate, ecallantide, or icatibant. Further, the guidelines stated that all patients with HAE should be trained to self-administer therapies, as early treatment has been shown to decrease the severity and duration of attacks and self-administration facilitates long-term prophylaxis. Additionally, every patient should be considered for home therapy, as it has also been shown to decrease the severity and duration of attacks, reduce morbidity and disability, improve quality of life and productivity, and reduce costs.

The WAO/EAACI noted that long-term prophylaxis with C1-INHs is also the preferred treatment for pediatric patients with HAE. Androgens are not recommended for pediatric patients and therefore antifibrinolytics are the second-line long-term prophylactic treatment option in this population. Pediatric patients on long-term prophylaxis should also have a supply of on-demand medication in case an attack occurs. The WAO/EAACI considers C1-INHs safe and effective for long-term prophylaxis in pregnant or nursing women, but androgens are contraindicated.

Hereditary Angioedema Association (HAEA) Medical Advisory Board

US Hereditary Angioedema Association Medical Advisory Board 2013 Recommendations for the Management of Hereditary Angioedema due to C1 Inhibitor Deficiency (2013)³⁹

In their 2013 guidelines, the HAEA noted that the decision to use long-term prophylaxis should be individualized and reflect the needs of the patient. Attack frequency and severity, comorbidities, availability of emergency care, and patient preference should all be taken into consideration before beginning long-term prophylaxis. Patients on long-term prophylaxis should have their treatment reviewed periodically to evaluate continued efficacy, safety, and dosing, and should be trained to self-administer treatment.

Both androgens and C1-INHs are listed as effective options for long-term prophylaxis, but patients on androgens should be monitored for potential adverse effects. The HAEA states that patients should not be required to attempt treatment with androgens before receiving C1-INH. All patients on androgens or C1-INHs for long-term prophylaxis should also have a supply of on-demand treatment for acute attacks.

Hereditary Angioedema International Working Group (HAWK) under the patronage of EAACI

Evidence-Based Recommendations for the Therapeutic Management of Angioedema owing to Hereditary Deficiency: Consensus Report of an International Working Group (2012)⁶⁶

In their 2012 guidelines, the HAWK stated that patients using on-demand treatment who still have more than 12 attacks per year or more than 24 days per year with severe symptoms should be candidates for long-term prophylaxis. The HAWK stated that androgens, including danazol and stanozolol, and C1-INHs may be used for long-term prophylaxis. The HAWK recommends that all patients with HAE should have a supply of at least one on-demand medication in the event of an attack, such as a C1-INH concentrate or recombinant inhibitor (Ruconest), icatibant, and/or ecallantide.

International Consensus on the Diagnosis and Management of Pediatric Patients with Hereditary Angioedema with C1 Inhibitor Deficiency (2017)¹⁹

In their guidelines for pediatric patients with HAE, the HAWK stated that long-term prophylactic therapy should be considered for patients with a decreased quality of life due to repeated HAE attacks. The HAWK noted that long-term prophylactic treatment options for pediatric patients include antifibrinolytics, C1-INHs, and androgens, but that antifibrinolytics, such as tranexamic acid, are traditionally the preferred therapy in this population. If antifibrinolytics fail to suppress attacks, C1-INHs should be considered the second-line therapy over androgens, which have a less-favorable safety profile. The HAWK cautioned that the safety of C1-INHs in pediatric patients has not yet been formally established, but level III evidence from clinical trials suggests that the safety and efficacy is similar between pediatric and adult patients.

Joint Task Force (JTF) on Practice Parameters (American Academy of Allergy, Asthma, and Immunology and the American College of Allergy, Asthma, and Immunology)

A Focused Parameter Update: Hereditary Angioedema, Acquired C1 Inhibitor Deficiency, and Angiotensin-Converting Enzyme Inhibitor–Associated Angioedema (2013)⁶⁷

In their 2013 parameter update, the JTF states that patients whose symptoms are not adequately controlled with on-demand therapy should be considered for long-term prophylaxis. Additional factors including attack frequency, severity, and location, access to emergency care, comorbidities, cost, and patient preference should also be taken into consideration before a patient is started on long-term prophylaxis. Patients on long-term prophylaxis should be continually evaluated, as the need for prophylaxis can change over time. Therapies for long-term prophylaxis include C1-INHs and androgens. Patients receiving long-term prophylaxis should have a treatment plan in place in the event of a breakthrough attack.

3. Comparative Clinical Effectiveness

3.1 Overview

To inform our review of the comparative clinical effectiveness of prophylaxis with C1-INHs (Cinryze and Haegarda) and lanadelumab in patients with HAE 1/2, we abstracted evidence from available clinical studies of these agents, whether in published or unpublished form (e.g. conference abstracts or presentations, FDA review documents). The draft version of this report also included data on Ruconest for long-term prophylaxis; however, as this drug is no longer under consideration for US FDA approval this indication, it is not addressed in the final version of this report.

We focused on evidence of the efficacy, safety, and effectiveness of long-term prophylaxis with lanadelumab and the C1-INHs in comparison with no long-term prophylaxis in our target population of patients with HAE 1/2. We also examined the effect of long-term prophylaxis in children under 12 years old as data permitted. Due to key differences in study eligibility criteria, baseline characteristics of study populations, and outcome measurements, we were unable to compare the C1-INHs and lanadelumab to each other through direct or indirect quantitative assessment.

Our review focused on assessing the key clinical outcomes assessed in trials, including clinician-assessed and patient-reported outcomes as well as reported harms.

- Clinical outcomes
 - HAE attacks
 - Use of rescue medication
 - Quality of life
 - Impact of attacks on school or work
 - Depression and anxiety
 - Mortality

- Key harms
 - Thrombotic events
 - Injection site reactions
 - Adverse events (AEs) leading to discontinuation
 - Headache
 - Hypersensitivity
 - Nasopharyngitis or upper respiratory tract infection
 - Nausea or vomiting
 - Dizziness
 - Transmission of infectious disease for plasma-derived products (e.g., hepatitis, Creutzfeldt-Jakob disease)

When reviewing clinical evidence in ultra-rare populations, ICER acknowledges the challenges of study design, recruitment, and availability of data on long-term outcomes. As such, when possible we aim to add to our findings specific context regarding areas of challenges in study design.

3.2 Methods

Data Sources and Searches

Procedures for the systematic literature review assessing the evidence on Cinryze, Haegarda, and lanadelumab followed established best research methods.^{68,69} We conducted the review in accordance with the Preferred Reporting Items for Systematic Reviews and Meta-Analyses (PRISMA) guidelines. The PRISMA guidelines include a list of 27 checklist items, which are described further in Appendix A1.

We searched MEDLINE, EMBASE, Cochrane Database of Systematic Reviews, and Cochrane Central Register of Controlled Trials for relevant studies. The most recent search was conducted on September 24, 2018. We limited each search to English-language studies of human subjects and excluded articles indexed as guidelines, letters, editorials, narrative reviews, case reports, or news items. We included abstracts from conference proceedings identified from the systematic literature search. All search strategies were generated utilizing the Population, Intervention, Comparator, and Study Design elements described in Section 1.

To supplement the database searches, we performed a manual check of the reference lists of included trials and reviews and invited key stakeholders to share references germane to the scope of this project. Further details of the search algorithms, methods for study selection, quality assessment, and data extraction are available in Appendix Tables A2 and A3, Figure A1, and Table D1.

Study Selection

We included evidence from all relevant published clinical studies irrespective of whether they used a comparative study design. We did not restrict our search by study duration or study setting. We excluded studies that do not meet our PICOTS criteria defined in Section 1.2. Studies conducted in patients with HAE Type 3 or in patients taking only on-demand therapy or short-term prophylaxis before medical procedures were also excluded.

In recognition of the evolving evidence base for HAE, we supplemented our review of published studies with data from conference proceedings, regulatory documents, information submitted by manufacturers, and other grey literature that met ICER standards for review (for more information, see <http://icer-review.org/methodology/icers-methods/icer-value-assessmentframework/grey->

[literature-policy/](#)). We excluded abstracts which reported duplicative data available in published articles.

Data Synthesis and Statistical Analyses

Data on relevant outcomes were summarized in evidence tables (see Appendix Table D1) and are synthesized in the text below. Due to major differences in entry criteria, study populations, study design and outcome measurements we did not formally compare the C1-INHs and lanadelumab to each other through quantitative indirect assessment, and therefore we focused our attention on describing the comparisons made within the clinical trials of each agent.

Assessment of Level of Certainty in Evidence

We used the [ICER Evidence Rating Matrix](#) to evaluate the level of certainty in the available evidence of a net health benefit among each of the interventions of focus (see Appendix D). ICER does not change its approach to rating evidence for ultra-rare conditions (see Appendix Figure D1).⁷⁰

Assessment of Bias

As part of our quality assessment, we evaluated the evidence base for the presence of potential publication bias. Given the emerging nature of the evidence base for newer treatments, we performed an assessment of publication bias for Cinryze, Haegarda, and lanadelumab using the [clinicaltrials.gov](#) database of trials. We scanned the site to identify studies completed more than two years ago that would have met our inclusion criteria and for which no findings have been published. Any such studies may have provided qualitative evidence for use in ascertaining whether there was a biased representation of study results in the published literature. For this review, we did not find evidence of any study completed more than two years ago that that has not subsequently been published.

3.3 Results

Study Selection

Our literature search identified 1,211 potentially relevant references (see Appendix Figure A1), of which 19 references (seven publications and 12 conference abstracts) related to six trials met our inclusion criteria. Primary reasons for study exclusion included study populations outside of our scope (e.g., patients with HAE Type 3), interventions not of interest (e.g., Berinert, Ruconest), indications not of interest (e.g., use in treatment of acute attacks, or short-term prophylaxis) and study type (e.g., case series, Phase I studies). Details of all included studies are summarized in Appendix D and in the sections that follow.

Cinryze

Seven references (six publications and one conference abstract) relating to one Phase III randomized controlled trial (RCT), one Phase III dose ranging trial in pediatric population, and two open-label single-arm studies focused exclusively on the use of Cinryze as long-term prophylaxis in HAE 1/2.

Haegarda

Eight references (one publication and eight conference abstracts) relating to one Phase III RCT focused exclusively on the use of Haegarda as long-term prophylaxis in HAE 1/2.

Lanadelumab

Four references (all conference abstracts) relating to one Phase III randomized controlled trial (RCT), focused exclusively on the use of lanadelumab as long-term prophylaxis in HAE 1/2.

Comparability of Evidence Across Key Trials of C1 Inhibitors and with Lanadelumab

We identified three key trials for this review, one for each drug.^{26,29,30} As noted above, key differences in entry criteria, study populations, study design and outcome measurements did not allow us to compare the C1-INHs to each other or to lanadelumab through quantitative indirect assessment. Although all three key studies recruited patients who had HAE 1/2, other eligibility criteria, such as age of patients and baseline frequency of HAE attack varied across trials. Furthermore, all studies were designed to measure the rate of HAE attacks during treatment period as the primary outcome. However, assessment of HAE attacks varied amongst the trials; this measurement was investigator based in two trials, while it was based on participant reports in one trial. In addition, the duration of treatment and length of trials also varied. Finally, two out of the three key trials used a placebo-controlled crossover design, while one study used a placebo-controlled parallel-arm design. These differences are summarized in Table 3.1. Further details about the characteristics of each trial are summarized in the section below.

Table 3.1. Trial Characteristics of Key Studies of C1-INHs and Lanadelumab for Long-Term Prophylaxis of HAE 1/2

	Cinryze (Zuraw 2010)	Haegarda (COMPACT)	Lanadelumab (HELP)
Eligibility Criteria	Age ≥ 6 years ≥ 2 attacks/month	Age ≥ 12 years ≥ 2 attacks/ month requiring immediate medical attention	Age ≥ 12 years ≥ 1 attack/month
Study Design	Phase III, cross-over, RCT	Phase III, cross-over, RCT	Phase III, parallel-arm, RCT
Outcome Measurement	Subject-reported indication of swelling at any location following a report of no swelling on the previous day	Investigator-confirmed HAE attacks	Investigator-confirmed HAE attacks
Treatment Duration	12 weeks	16 weeks	26 weeks

Quality of Individual Studies

Of the six identified trials, we did not assign a quality rating to the two trials that have not yet been published (HELP and Aygören-Pürsün 2018). All the remaining four trials were all judged to be of fair quality using criteria from the US Preventive Services Task Force (USPSTF) (see Appendix E).⁷¹ Trials of fair-quality studies reported slight imbalances in baseline characteristics, showed some differences in follow-up between trial arms, used less reliable measurement instruments to assess outcomes, did not use intention to treat analysis as the main outcome, and not all potential confounders were addressed. We did not assign a quality rating to references that were obtained from grey literature sources (e.g., conference proceedings).

Trial Characteristics

Cinryze

Data to inform our assessment of Cinryze in patients with HAE 1/2 were mainly derived from four trials: one Phase III RCT (Zuraw 2010), one Phase III dose ranging trial in a pediatric population, and two open-label, single-arm studies.^{26-28,72} The Phase III, crossover RCT was identified as the key trial for Cinryze. In this trial, Cinryze was compared to placebo in preventing HAE attacks in patients with HAE 1/2.²⁶ The study consisted of two 12-week treatment periods, and 22 participants were randomly assigned to receive either 1,000 IU Cinryze or placebo intravenously (every three to four days) during the first treatment period and then crossed over to the treatment that was not received during the first period.²⁶ All patients were required to be six years or older with a history of two or more HAE attack per month, and were allowed to continue stable doses of any prophylactic androgen or antifibrinolytic drugs therapy they were on in the 30 days before the study commenced.²⁶ The primary outcome was the number of HAE attacks during each treatment period identified from daily diary recording of symptoms by patients. An attack was defined as patient-reported indication of swelling at any location following a report of no swelling on the

previous day.⁷³ Other secondary outcomes assessed include average severity of attacks, average duration of attacks, number of doses of rescue medication used and duration of swelling.²⁶

The Phase III trial in pediatric patients is an ongoing, randomized, multicenter, dose-ranging crossover study (N=12). Patients in this trial were required to be between the ages of 6 and 12 years, with HAE 1/2 and a monthly average attack rate of at least one (classified as moderate, severe, or needing acute treatment) in a three-month period.²⁷ The trial included a 12-week baseline observation period to confirm the baseline attack frequency, after which patients were randomly assigned to 500 IU or 1,000 IU of Cinryze in a crossover fashion. The primary outcome was the number of HAE attacks per month during each treatment period.²⁷

The other two Cinryze trials were open-label trials (Zuraw 2012 [N=146]; Bernstein 2015 [N=20]).^{28,72} Both trials enrolled patients who had a history of at least one HAE attack per month. One of the studies assessed the frequency of HAE attacks compared to historical attacks and long-term safety,²⁸ while the other one focused primarily on safety of escalating the dose of Cinryze.⁷²

Haegarda

Data to inform our assessment of the clinical effectiveness of Haegarda were mainly drawn from one published Phase III trial (COMPACT).²⁹ COMPACT was a 32-week, multicenter, crossover, placebo-controlled trial that consisted of two 16-week treatment periods following a two-week run in period.²⁹ The trial enrolled 90 patients with HAE 1/2, and participants were required to be 12 years or older with at least two HAE attacks requiring immediate treatment, medical attention, causing clinically significant functional impairment during any consecutive four-week period (or at least one attack during the two-week run-in period).²⁹ Participants could continue stable doses of prophylactic androgen or antifibrinolytic therapy they were on for the duration of the study. Participants were randomized into four groups to receive either one of the two doses of Haegarda (40 IU/kg or 60 IU/kg) administered subcutaneously during the first 16-week treatment period and followed by placebo in the second treatment period (or placebo first followed by Haegarda).²⁹ Patients who had more than 12 attacks in any four-week consecutive period were allowed to either move on to the next treatment period or stopped the trial based on the investigator's discretion.²⁹ The primary outcome was the number of investigator-confirmed HAE attacks during each treatment period. Secondary outcomes were the percentage of patients who had a clinical response (defined as greater than 50% reduction in number of HAE attack vs. placebo) and the number of times that rescue medication was used.

Lanadelumab

Data to inform our assessment of lanadelumab in patients with HAE 1/2 were drawn from one unpublished trial (HELP Study).³⁰ HELP was a 26-week, Phase III, multicenter, parallel-arm, RCT with four-week run in period.³⁰ The trial enrolled 125 patients with HAE 1/2, and participants were

required to be 12 years or older with at least one investigator confirmed HAE attack over a four-week period during the run-in period.³⁰ All patients were required to be off all long-term HAE prophylaxis for a minimum of two weeks before study entry.³⁰ Participants were randomized to receive one of three doses of lanadelumab (300 mg every two weeks, 300 mg every four weeks, 150 mg every four weeks) subcutaneously or placebo over 26 weeks.³⁰ The primary outcome in the HELP study was the number of investigator-confirmed HAE attacks over 26 weeks.³⁰ An HAE attack was defined in the trial as a discrete episode during which the participant progressed from no angioedema to symptoms of angioedema.⁷⁴

Table 3.2. Key Trial Characteristics for Pivotal Trials for HAE Long-Term Prophylaxis Drugs

Drug/Key Trials	Treatment Arms	Patient Characteristics	Follow Up	Primary Outcomes
Cinryze (Zuraw 2010) Phase III, Crossover, RCT	1,000 IU Cinryze Placebo	Number of patients = 22 Mean age: 34.5 years Female: 86% Baseline attack/month: NR Baseline androgen therapy: 14%	Two 12-week periods	Patient-reported HAE attack rates
Haegarda (COMPACT) Phase III, Crossover, RCT	Haegarda (40 IU/kg or 60 IU/kg) Placebo (high or low volume)	Number of patients = 90 Mean age: 39.6 years Female: 67% Baseline attack/month: 3.3 Baseline androgen therapy: 21%	Two 16-week periods	Investigator-confirmed HAE attack rates
Lanadelumab (HELP) Phase III, Parallel-Arm, RCT	Lanadelumab 300 mg q2wks Lanadelumab 300 mg q4wks Lanadelumab 150 mg q4wks Placebo	Number of patients = 125 Mean age: 41 years Female: 64% Baseline attack/month: 3.5 Baseline androgen therapy: NR	26 weeks	Investigator-confirmed HAE attack rates

Clinical Benefits

HAE Attacks

Cinryze

Results from one RCT showed that prophylaxis with Cinryze significantly reduced the frequency, severity, and duration of HAE attacks in patients six years of age and older when compared to no

prophylaxis. Two additional trials also reported significant improvement with Cinryze prophylaxis when compared to baseline period.

The primary outcome in the Phase III RCT (Zuraw 2010) was the total number of patient-reported HAE attacks during the treatment periods.²⁶ The mean normalized rate of HAE attack for all participants during the two 12-week crossover periods was 6.26 for Cinryze and 12.73 for placebo (mean difference: 6.47; 95% confidence interval [CI]: 4.21 – 8.73; $p < 0.001$).²⁶ Monthly attack rate was not reported; however, based on the data presented in the manuscript, we estimated it to be 2.09 per month while on Cinryze, and 4.24 per month while on placebo, representing about a 50% reduction in frequency of HAE attacks while on Cinryze compared to placebo. The mean score for severity of HAE attacks assessed by the patients (on a 3-point scale, 1 indicates mild attack and 3 indicates severe attack) was significantly lower with Cinryze compared to placebo (1.9 [standard deviation (SD): 0.4] vs. 1.2 [SD: 0.9]).²⁶ The total duration of HAE attacks and days of swelling were also significantly shorter with Cinryze than with placebo (see Table 3.3). In addition, only half of the patients on Cinryze ($n=11$) required rescue medication for attacks, compared with all 22 patients requiring rescue medication use in the placebo group. Average number of uses of rescue medication during the trial was also lower with Cinryze than placebo (4.7 vs. 15.4).²⁶

A subgroup analysis was conducted in participants younger than 18 years old. In total, there were four children enrolled (aged 9-17 years). Similar to the overall population, there was about a 50% reduction in the number of HAE attacks occurring among the children while on Cinryze compared to when they were on placebo (mean number of attacks over 12 weeks: 7.0 vs. 13.0; SD and p-value not reported).⁷⁵

In a separate trial assessing 500 IU and 1,000 IU doses of Cinryze in an exclusively pediatric population (Aygören-Pürsün 2018), the monthly mean HAE attack rate among patients was 1.15 (SD: 1.53) on 500 IU of Cinryze and 0.74 (SD: 1.35) attacks on 1,000 IU of Cinryze, representing 71% and 85% reductions, respectively, compared to the mean baseline attack rate of 3.7 (SD: 3.2) attacks per month.²⁷ The cumulative attack severity (sum of the 3-point severity score on each attack) was reduced during the 12-week period patients were on 500 IU and 1,000 IU of Cinryze compared to the 12-week baseline period (2.01 and 1.36 vs. 7.19).²⁷ Similarly, there was a reduction in the number of attacks requiring rescue medication while patients were on Cinryze prophylaxis compared to baseline period (mean number of attacks requiring rescue treatment: 0.44 and 0.15 vs. 3.25).²⁷

In the single-arm open-label extension study by Zuraw et al. (Zuraw 2012) conducted in 146 participants greater than one year old, with follow-up of up to 2.6 years, there was a statistically-significant reduction in the average monthly HAE attack rate of patients on Cinryze prophylaxis (mean: 0.47 ± 0.8 ; median: 0.19, interquartile range: 0-0.64) when compared to the average historical attack rates (mean: 4.7 ± 5.2 ; median: 3, IQR: 2-4).²⁸

Table 3.3. Cinryze Pivotal Trial (Zuraw 2010): Clinical Outcomes

Clinical Outcomes	Cinryze	Placebo
Total HAE Attacks		
Mean HAE Attack Rate Over 12 Weeks	6.26*	12.73
Mean HAE Attack/Month (Estimated)	2.09	4.24
Percentage Reduction in Total HAE Attack vs. Placebo (Estimated)	50.5%	--
Additional Outcomes Related to HAE Attacks		
Mean (SD) Severity of HAE Attack†	1.2* (0.9)	1.9 (0.4)
Mean (SD) Duration of HAE Attack, Days	2.1* (1.1)	3.4 (1.4)
Mean (SD) Duration of Swelling, Days	10.1* (10.7)	29.6 (16.9)
Mean Number of Rescue Therapy	4.7* (8.7)	15.4 (8.4)

*p<0.001.

†Based on a 3-point scale [1- mild, 2-moderate, 3-severe].

Haegarda

Results from one RCT showed that prophylaxis with Haegarda significantly reduced the frequency, severity, and duration of HAE attacks in patients 12 years and older when compared to no prophylaxis.

The primary outcome in the COMPACT trial was the total number of investigator-confirmed HAE attacks during the treatment periods.²⁹ The rate of HAE attacks was significantly reduced when patients were on twice weekly subcutaneous doses of Haegarda (40 IU/kg or 60 IU/kg) compared to their corresponding placebo group (1.19 vs. 3.61 attacks/month when using 40 IU/kg and 0.52 vs. 4.03 attacks/month when using 60 IU/kg; both p<0.001).²⁹ The mean reduction in HAE attacks versus placebo was estimated to be 55% in the 40 IU group, and 84% in the 60 IU group (median reduction was 89% and 95%, respectively).²⁹ All secondary outcomes were also in favor of Haegarda. In total, 76% of patients on 40 IU Haegarda and 90% of patients on 60 IU Haegarda achieved 50% reduction in HAE attacks versus placebo.²⁹ In addition, more patients on Haegarda prophylaxis were attack free over the duration of the study (38%-40%) compared to those on placebo (9%). Haegarda also resulted in a significant reduction in the severity of HAE attacks (on a 3-point scale, with 1 indicating mild attack and 3 representing severe attack) compared to placebo (40 IU group: 1.8 [0.6] vs. 2.0 [0.5]; 60 IU group: 1.6 [0.6] vs. 1.9 [0.5]).²⁹ Similarly, the total duration of HAE attacks was significantly shorter and use of rescue medication was significantly reduced with Haegarda compared with placebo (see Table 3.4).

Table 3.4. Haegarda Pivotal Trial (COMPACT): Clinical Outcomes

Clinical Outcomes	40 IU/kg Haegarda Group		60 IU/kg Haegarda Group	
	Haegarda	Placebo	Haegarda	Placebo
Total HAE Attacks				
Number of HAE Attack/Month, Mean	1.2* (0.5 - 1.9)	3.6 (3.0 - 4.3)	0.5* (0.0 – 1.0)	4.0 (3.5 – 4.6)
Percentage Reduction in Total HAE Attack vs. Placebo	55%	---	84%	---
Additional Outcomes Related to HAE Attacks				
Number of Rescue Therapy/Month, Mean	1.1 (-1.4 – 3.7)	5.6 (3.1 - 8)	0.3 (-0.3 – 1.0)	3.9 (3.2 - 4.6)
Severity of HAE Attack, Mean†	1.8 (0.6)	2 (0.5)	1.6 (0.6)	1.9 (0.5)
Number of Days of HAE Attack/Month, Mean	1.6 (2.6)	7.0 (5.8)	1.6 (4.4)	7.5 (5.6)

*p<0.001.

†Based on a 3-point scale [1- mild, 2-moderate, 3-severe].

Lanadelumab

Results from one RCT showed that prophylaxis with lanadelumab significantly reduced the frequency and severity of HAE attacks in patients 12 years and older when compared to no prophylaxis.

The primary outcome in the HELP trial was the total number of investigator-confirmed HAE attacks over 26 weeks.³⁰ The number of investigator-confirmed HAE attacks requiring acute treatment, and the number of moderate or severe investigator-confirmed HAE attacks were reported as secondary outcomes. The total mean HAE attack rate was significantly lower for all patients on all three lanadelumab doses (300 mg q2wks, 300 mg q4wks, and 150 mg q4wks) when compared to those on placebo (0.26, 0.53, and 0.48 attacks per month vs. 1.97 attacks per month; all p<0.001), resulting in a 73% to 87% reduction in the frequency of HAE attacks (see Table 3.5).³⁰ More patients on lanadelumab prophylaxis were attack-free over the duration of the study (39%-44%) compared to those on placebo (2%).³⁰ In addition, patients on all three lanadelumab doses showed a statistically-significantly lower rate of attacks requiring acute treatment compared to those on placebo (0.21, 0.42, and 0.31 attacks per month vs. 1.64 attacks per month; all p<0.001), resulting in 74% to 87% reduction in the frequency of HAE attacks requiring rescue medication (see Table 3.5).³⁰ Similarly, significant differences in favor of lanadelumab prophylaxis compared to placebo were observed in the rates of investigator-confirmed moderate or severe HAE attacks (see Table 3.5).

We also identified an exploratory analysis that assessed the efficacy of lanadelumab by baseline attack frequency in the HELP trial.⁷⁶ Irrespective of baseline attack rate, the monthly attack rates was significantly reduced among patients on lanadelumab relative to placebo: less than two baseline attacks (N = 12; 51% to 93% reduction vs. placebo; all p<0.05); two to less than three baseline attacks (N = 22; 77% to 91% reduction vs. placebo; all p<0.001); baseline attack rate of

three or more (N = 65; 70% to 86% reduction vs. placebo; all p<0.001).⁷⁶ In addition, we identified another exploratory analysis on the HELP trial that assessed the impact of prior use of long-term prophylaxis. About half of all participants in the trial previously used C1-INHs as long-term prophylaxis, and the reduction in the number of attack on lanadelumab versus placebo was similar in magnitude to those who had not received prior long-term prophylaxis (74%-83% vs. 76%-87%).⁷⁷

Table 3.5. Lanadelumab Pivotal Trial (HELP): Clinical Outcomes

Clinical Outcomes	Lanadelumab 300 mg q2wks	Lanadelumab 300 mg q4wks	Lanadelumab 150 mg q4wks	Placebo
Total HAE Attacks				
Mean Rate of Attack (Attacks/4 Weeks)	0.26*	0.53*	0.48*	1.97
Percentage Reduction in Total HAE Attack vs. Placebo (95% CI)	87 (93, 76)	73 (82, 60)	76 (85, 62)	--
Additional Outcomes Related to HAE Attacks				
Percentage Reduction in Attacks Requiring Acute Treatment vs. Placebo (95% CI)	87 (94, 75)	74 (84, 59)	81 (89, 66)	--
Percentage Reduction in Moderate or Severe Attacks vs. Placebo (95% CI)	83 (92, 67)	73 (84, 55)	71 (83, 50)	--

*p<0.001.

Health-Related Quality of Life and Other Outcomes

Effects of prophylaxis on health-related quality of life were inconsistent in the trials. We found no mortality data for any of the drugs.

Cinryze

The 36-item short form survey (SF-36), which is used to assess the health-related quality of life of patients, was measured as a secondary outcome in the Phase III RCT by Zuraw et al. (Zuraw 2010).⁷⁸ The SF-36 questionnaire is only valid for patients aged 18 years and older, therefore, three patients in the trial who were younger than 18 years old were not eligible to complete the form. Higher scores in the SF-36 form are indicative of better health related quality of life. The mean SF-36 on both the physical component (PCS) and mental component (MCS) at the end of the placebo period were similar to or lower than baseline (PCS: 37 ± 11.6 vs. 36.4 ± 10.2; MCS: 45 ± 16.1 vs. 49.9 ± 10.0), while the scores at the end of the Cinryze period were generally greater (PCS: 43.9 ± 12.8 vs. 36.4 ± 10.2; MCS: 54 ± 7.8 vs. 49.9 ± 10.0).⁷⁸ However, statistical significance was not reported.⁷⁸ We did not identify any data specifically related to impact of Cinryze on school or work, depression and anxiety, or mortality.

Haegarda

One abstract reported exploratory analyses on patient-reported outcome measures in the COMPACT trial using the European Quality of Life-5 Dimensions Questionnaire (EQ-5D), Hospital Anxiety and Depression Scale (HADS), and Work Productivity and the Activity Impairment Questionnaire (WPAI).⁷⁹ There was no meaningful difference observed on EQ-5D, HADS or WPAI subscale of absenteeism (health-related absenteeism) while patients were on Haegarda compared with placebo. However, prophylaxis with Haegarda resulted in a clinically-meaningful improvement compared with placebo on other subscales of WPAI: presenteeism (-15.86 [-25.21 to -6.52]), work productivity loss (-9.97 [-30.84 to -9.10]), and activity impairment (-19.83 [-27.28 to -11.88]).⁷⁹ We did not identify any data specifically related to impact of Haegarda on mortality.

Lanadelumab

The angioedema quality of life questionnaire (AE-QoL) is a specific patient-reported tool used to assess health-related quality of life in patients with recurrent angioedema. It was measured as a secondary outcome in the HELP trial. A change of six points in the AE-QoL has been previously defined as the minimum clinically important difference.⁸⁰ Reduction was observed in the AE-QoL score for all arms of the trial during the study period, however, patients treated with lanadelumab experienced greater reductions in AE-QoL total scores and all domain scores compared with placebo (-19.47 (±18.56) vs. -4.71 (±18.64); p<0.01). In addition, higher cumulative proportions of patients in the three lanadelumab treatment arms (300 mg q2wks, 300 mg q4wks, and 150 mg q4wks) achieved the minimum clinically-important difference value of six points in AE-QoL total score (63%, 65%, and 81% respectively vs. 37% with placebo; all p<0.05).⁸¹

We did not identify any data specifically related to impact of lanadelumab on school or work, depression and anxiety, or mortality.

Harms

Serious adverse events and adverse events leading to trial discontinuation were rare and generally similar between trial arms. Mild infections, headaches, hypersensitivity, dizziness, and injection site reactions were the most common side effects noted during the trial periods. Long-term safety data related to prophylaxis use were identified only for Cinryze.

The majority of the AEs reported in the randomized controlled trials of C1-INHs and lanadelumab were mild or moderate (see Table 3.6). Serious AEs, deaths, and AEs leading to trial discontinuation were rare and generally similar between trial arms. The most commonly-reported AEs included mild infections (upper respiratory tract infection, nasopharyngitis, sinusitis), headache, hypersensitivity, and dizziness. In addition, injection site reactions, which occurred in 31% of patients on Haegarda in the COMPACT trial, and 60% of patients on lanadelumab in the HELP trial were the most commonly reported AE in the trials of drugs administered subcutaneously.^{29,30}

In addition, we identified a study that assessed the safety of escalating doses of Cinryze (Bernstein 2014).⁷² Although the RCT of Cinryze assessed a dose of 1,000 IU every three or four days, the FDA label states that doses of up to 2,500 IU (not exceeding 100 IU/kg) every three or four days may be considered based on individual patient response.⁸² In Bernstein 2014, the safety of escalating the dose of Cinryze up to 2,500 IU was assessed in 20 patients over a 12 week-period.⁷² Of the 20 patients who initiated treatment with 1,500 IU of Cinryze in the trial, 13 escalated to 2,000 IU and 12 escalated to 2,500 IU based on treatment response.⁷² Overall, Cinryze was well-tolerated at all dose levels, and the majority of identified AEs were mild to moderate and unrelated to the study.⁷² There were two cases of AEs in two patients that were considered by the investigators to be related to the study drug (blood clot in the port and muscle spasm); both were mild and resolved without complication.⁷²

Long-term safety data related to prophylaxis use were identified only for Cinryze (Zuraw 2012). The patterns of AEs reported in this long-term, single-arm, open label extension study were similar to those reported during the randomized controlled trial period. Investigators found no cases of discontinuation due to AEs among the 146 patients on 1,000 IU of Cinryze for a period of 2.6 years.²⁸ Thromboembolic events were observed in five patients with underlying risk factors for thrombotic events and all were deemed not to be related to the use of Cinryze.²⁸ In addition, there were two deaths which the investigators considered not to be related to the use of Cinryze.²⁸

Table 3.6. Adverse Events of Cinryze, Haegarda and Lanadelumab

	Any AE	Related AE	SAE	Related SAE	Discontinue Due to AE	Injection Site Reaction	Hypersensitivity	URTI	Headache
Cinryze (Zuraw 2010)²⁶									
Cinryze	20 (87)	3 (14)	0	0	0	NR	1 (8)	NR	NR
Placebo	1 (4)	0	2 (8)	0	0	NR	0	NR	NR
Haegarda (COMPACT)²⁹									
Haegarda	59 (69)	29 (34)	1 (1)	0	2 (2)	27 (31)	5 (6)	6 (7)	NR
Placebo	57 (66)	22 (26)	2 (2)	1 (1)	1 (1)	21 (24)	1 (1)	6 (7)	NR
Lanadelumab (HELP)³⁰									
Lanadelumab	76 (91)	NR	NR	0	NR	50 (60)	NR	20 (24)	17 (20)
Placebo	31 (76)	NR	NR	0	NR	13 (32)	NR	11 (27)	8 (20)

NR: not reported, AE: adverse event, SAE: serious adverse event, URTI: upper respiratory tract infection

Controversies and Uncertainties

Although trials of long-term prophylaxis with C1-INHs and lanadelumab showed benefits in reducing the frequency of HAE attacks with few harms, the evidence base is limited. We identified only three randomized controlled trials meeting our inclusion criteria, one of each drug of interest in our review, and the study populations were small. This is to be expected with an ultra-rare disease. In two of the three trials (Cinryze and Haegarda trials) there was no washout period despite the crossover design and so carryover effects during periods of active treatment are possible. In the

trials of C1-INHs, patients could remain on androgen prophylaxis, but subgroup analyses were not reported for these patients.

The trials were of short duration, assessing outcomes by four to 26 weeks, leaving questions about the durability of effect of the interventions and long-term safety. Although we have fewer concerns about the safety profile of C1-INHs, given longer experience with their use in both acute treatment and prophylaxis,^{16,28,72,83} we have substantially less information on lanadelumab, which works through a different mechanism of action. Longer-term studies are ongoing (NCT02741596) and additional data will be needed to demonstrate long-term safety.

We did not identify any trial comparing any of the drugs of interest to each other. Network meta-analysis was not deemed feasible due to the limited number of available studies and major differences in the study design, inclusion criteria and populations. The primary outcome, frequency of HAE attacks, was not consistently defined or identified across trials, making inter-trial comparisons difficult. The Cinryze trial used patient-reported swelling as indication of HAE attacks, while the trials of Haegarda and lanadelumab used investigator-confirmed HAE attacks. It is unclear if there was a follow-up confirmation of reported HAE attacks by the investigators in the Cinryze trial. Furthermore, there is no general agreement on whether attacks occurring within 48 hours of each other should be considered as a single attack or separate attacks. In addition, the baseline frequency of HAE attacks varied across trials. There were also differences across trials in patient age, study duration, and the reported secondary clinical outcomes (e.g., use of rescue medication, severity of attacks). As such, our review focused on describing the comparisons made within the clinical trials of each agent (i.e., comparing the benefits and harms of C1-INHs and lanadelumab to placebo).

We found very limited evidence on patient-reported outcomes from the clinical trials. We heard from many stakeholders that HAE can have significant effects on patients' quality of life. Due to the unpredictability of attacks, and the variability in attack frequency and severity, patients describe anxiety in their daily lives, the need to carry on-demand therapy at all times, hindered career or educational advancement, and a high burden on caregivers. However, quality of life measures were infrequently and inconsistently measured across trials, and no trials to date have used the disease-specific HAE-QoL as an assessment of quality of life. We found even less evidence on impact of long-term prophylaxis on school or work, depression, and anxiety.

There is limited or no data on some important patient subgroups, including children younger than age 12 and pregnant or lactating women.

Finally, it is uncertain how, if at all, the results found in this report generalize to patients with HAE not due to deficient C1-INH (Type 1) or dysfunctional C1-INH (Type 2). We have heard that there is substantial uncertainty as to whether HAE patients with normal C1-INH (HAE Type 3) benefit from prophylaxis with C1-INHs.

3.4 Summary and Comment

Results from clinical trials suggested that the drugs currently approved or under consideration for long-term prophylactic treatment of HAE 1/2 provide clinical benefits to many patients in terms of reduction of the number and severity of HAE attacks compared with no long-term prophylaxis. No SAEs were seen during the short duration of the trials. However, limitations to the evidence base that should be noted include:

- Small trial populations due to the ultra-rare status of the disease
- Short follow-up during the trials (four to 26 weeks), such that data on durability of effect and long-term safety are lacking
- Lack of consistently-defined and -reported outcomes making comparisons across trials difficult
- Limited data on quality of life and other patient-reported outcomes
- Limited data in some populations, including children and pregnant or lactating women
- Lack of head-to-head trials of the drugs

Figure 3.1. ICER Evidence Rating Matrix

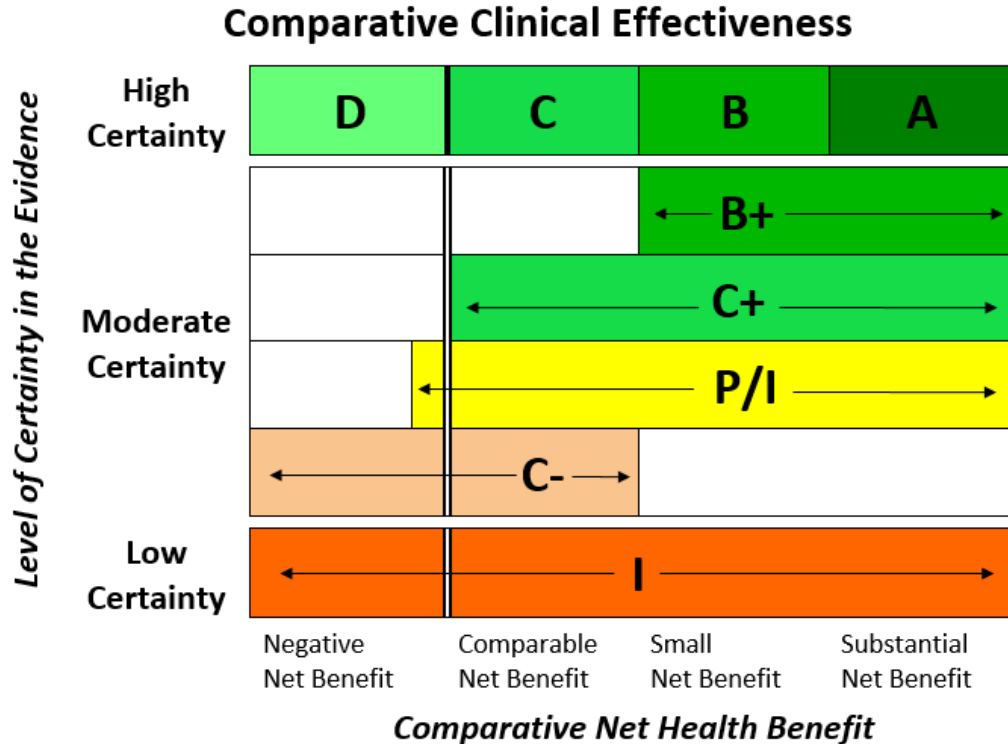

- A = "Superior" - High certainty of a substantial (moderate-large) net health benefit*
- B = "Incremental" - High certainty of a small net health benefit*
- C = "Comparable" - High certainty of a comparable net health benefit*
- D = "Negative" - High certainty of an inferior net health benefit*
- B+ = "Incremental or Better" - Moderate certainty of a small or substantial net health benefit, with high certainty of at least a small net health benefit*
- C+ = "Comparable or Better" - Moderate certainty of a comparable, small, or substantial net health benefit, with high certainty of at least a comparable net health benefit*
- P/I = "Promising but Inconclusive" - Moderate certainty of a comparable, small, or substantial net health benefit, and a small (but nonzero) likelihood of a negative net health benefit*
- C- = "Comparable or Inferior" - Moderate certainty that the point estimate for comparative net health benefit is either comparable or inferior*
- I = "Insufficient" - Any situation in which the level of certainty in the evidence is low*

Despite these limitations, the pivotal studies of C1-INHs show that they are effective in reducing the number of HAE attacks without significant adverse effects when compared to no prophylaxis. Because some C1-INHs (Berinert and Ruconest) have also been used for years for on-demand therapy, there are some long-term safety data that are reassuring. Thus, for patients with HAE 1/2 who are eligible for long-term prophylaxis, we rated the evidence for both the C1-INHs (Cinryze and Haegarda) as demonstrating a high certainty of substantial net health benefit compared with no prophylaxis ("A").

For lanadelumab, which targets a different pathway than the C1-INHs, the results of the pivotal trial are promising in terms of clinical efficacy for reducing HAE attacks compared to no prophylaxis. However, new biologic therapies frequently are found to have safety concerns in the years after they are introduced that were not detected in pre-approval trials.³¹ Without long-term safety data

available, we rated the evidence for lanadelumab as promising but inconclusive (“P/I”), demonstrating a moderate certainty of a comparable or substantial net health benefit, and a small (but non-zero) likelihood of a negative net health benefit.

Table 3.7. ICER Evidence Ratings of HAE Drugs for Long-Term Prophylaxis Compared with No Prophylaxis

Drug	Evidence Rating
Cinryze	A
Haegarda	A
Lanadelumab	P/I

While we cannot preclude differences in efficacy and safety among the C1-INHs given that there are differences in formulation (plasma-derived vs. recombinant medication) and delivery (intravenous vs. subcutaneous), we were unable to compare any of the agents to each other due to the lack of head-to-head trials, and differences in the trial population. As such, we determined the evidence to be insufficient (“I”) to judge the net health benefits of each C1-INH compared to one another and lanadelumab.

4. Long-Term Cost Effectiveness

4.1 Overview

The primary aim of this analysis was to estimate the cost effectiveness of lanadelumab and two C1-INHs (Cinryze and Haegarda) for long-term prophylaxis against acute attacks in patients with HAE 1/2. The model structure for this assessment is described below. The model was developed in Microsoft Excel.

We estimated the expected direct and indirect costs for each attack, expected disutility for each attack, expected probability of death per attack, and the expected duration with symptoms per attack.

Each model cycle lasted one month. For each intervention, we calculated the number of attacks in each cycle, the probability of death given the number of attacks in each cycle, patient survival, time spent “attack free,” quality-adjusted survival, and health care costs. Outcomes were summed over a lifetime horizon for each intervention. Differences in survival, quality-adjusted survival, and costs between each prophylactic therapy and no prophylaxis were used to calculate incremental cost-effectiveness ratios.

Model outcomes of interest included:

- By intervention:
 - Total health care costs (undiscounted and discounted)
 - Direct health care costs (undiscounted and discounted)
 - Indirect health care costs (undiscounted and discounted)
 - Number of attacks
 - Life years (undiscounted and discounted)
 - QALYs (undiscounted and discounted)
- Pairwise comparisons:
 - Incremental cost-effectiveness ratios (cost per attack avoided, cost per life-year gained, and cost per QALY gained) of each prophylactic therapy versus no long-term prophylaxis

4.2 Methods

Model Structure

We developed a Markov model with two health states: “alive with HAE” and “dead” (Figure 4.1). The model used one-month cycles over a lifetime horizon. Transitions from the “alive with HAE”

state to “dead” were based on background mortality from US life tables and HAE-specific mortality. Within the “alive with HAE” health state, we tracked health-related quality of life, number of acute attacks and time spent in acute attack. For each attack, we tracked the severity of attack, anatomical location of the attack for severe attacks (i.e., laryngeal and non-laryngeal), mortality from asphyxiation due to laryngeal attack, and attack-specific disutility, as well as treatment patterns (setting and drugs), emergency department (ED) visits, hospitalizations, and associated costs (Figure 4.2). These outcomes were tracked over time for persons receiving long-term prophylaxis with lanadelumab and the C1-INHs, and those not receiving long-term prophylaxis.

The base-case analysis used a US health care system perspective (i.e., focusing on direct medical care costs only) with a 3% discount rate for both costs and health outcomes. ICER’s modified value assessment framework for ultra-rare conditions calls for consideration of a co-base-case analysis taking a societal perspective when those costs are large in relation to health care costs. As the societal costs of HAE 1/2 are small in relation to health care costs, we have included this analysis as a scenario.

Figure 4.1. Model Framework

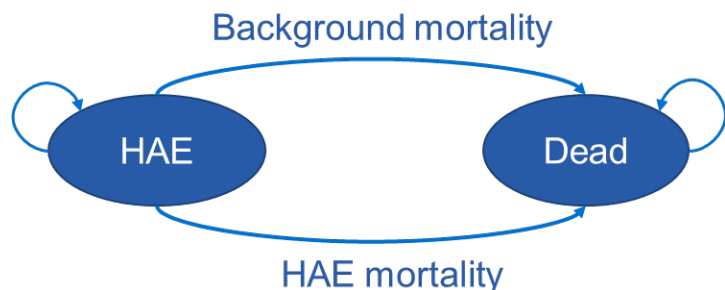
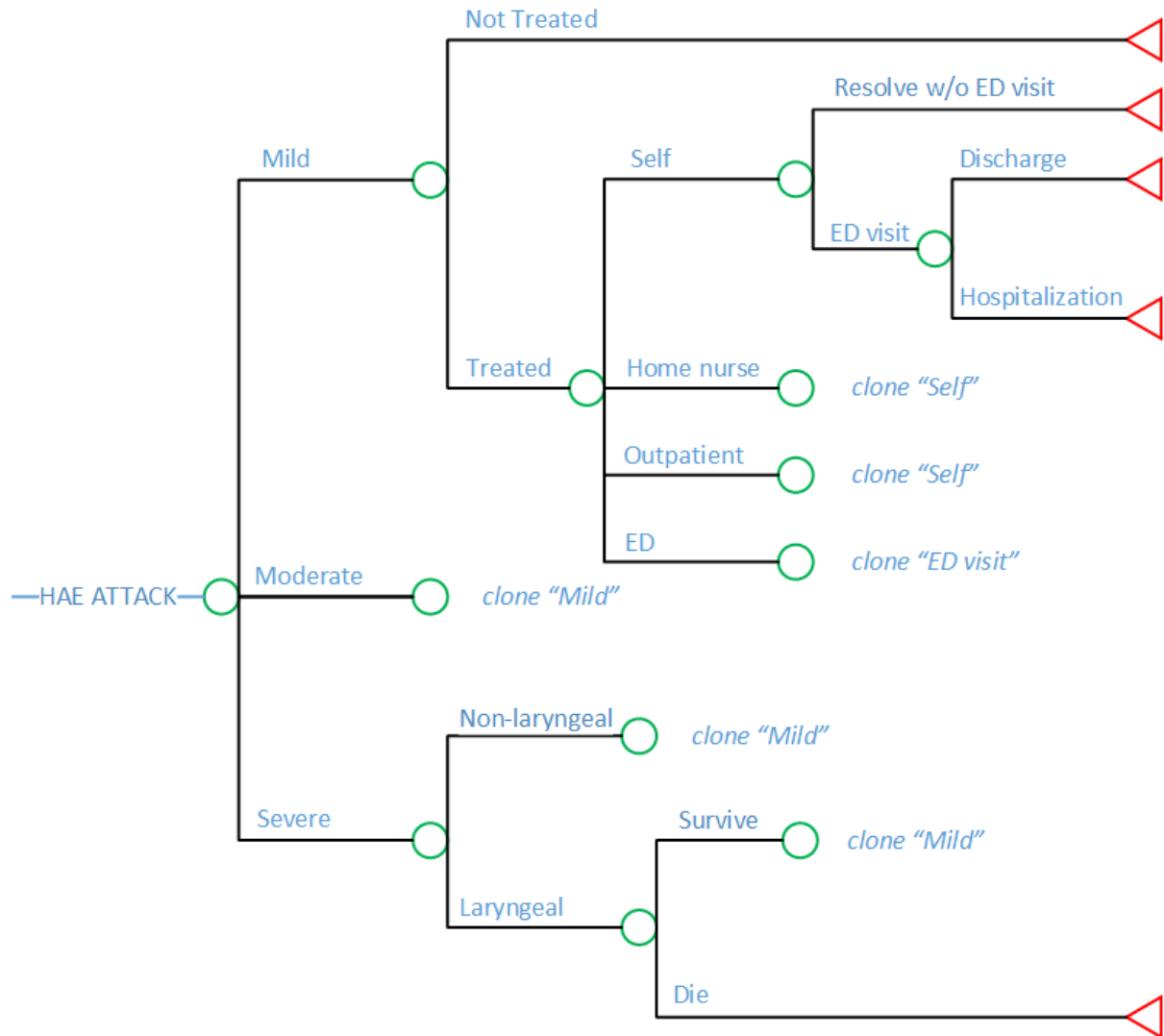

Figure 4.2. HAE Attack Pathway



Legend: This figure reflects how payoffs (i.e., costs and utilities) associated with the different HAE attack events and outcomes are weighted. Green circles are chance nodes. Red triangles are terminal nodes. “Clone” refers to structural replication of a previously described branch of the decision tree (i.e., not replication of probabilities). “ED” refers to emergency department.

Target Population

The population for this analysis consisted of patients in the US with HAE 1/2 who are candidates for long-term prophylactic treatment. The baseline age, gender, and attack frequency used in the model reflected the weighted average of these baseline characteristics across the three pivotal clinical trials for the interventions;^{29,30,41} the baseline weight for males and females was obtained from Centers for Disease Control and Prevention (CDC) anthropometric reference data (Table 4.1).⁸⁴

Table 4.1. Baseline Values for Patient Population

Variable	Value	Source
Age in Years (Mean)	39.6	Banerji et al. 2017, Longhurst et al. 2017, Zuraw et al. 2010 ^{29,30,41}
Gender (% Female)	68.4%	Banerji et al. 2017, Longhurst et al. 2017, Zuraw et al. 2010 ^{29,30,41}
Weight, Females (kg)	76.4 (SD: 30.93)	Fryar et al. 2016 ⁸⁴
Weight, Male (kg)	88.8 (SD: 31.11)	Fryar et al. 2016 ⁸⁴
Baseline Attack Frequency (per Month)	3.39	Banerji et al. 2017, Longhurst et al. 2017, Zuraw et al. 2010 ^{29,30,41}

SD: standard deviation

Treatment Strategies

Interventions

The interventions assessed in this model were:

- Cinryze (C-INH, intravenous injection [human])
- Haegarda (C1-INH, subcutaneous injection [human])
- Lanadelumab

Comparators

The comparator was no long-term prophylaxis. Patients in all intervention and comparator groups could receive on-demand treatment for acute attacks.

Key Model Characteristics and Assumptions

Table 4.2. Key Model Assumptions

Assumption	Rationale
HAE-specific mortality results only from asphyxiation following a laryngeal attack; other anatomical locations for acute attacks do not result in death or permanent disability.	Death from HAE attacks primarily results from asphyxiation following a laryngeal attack. ⁸⁵ We found no evidence that HAE attacks result in permanent disability.
Death due to asphyxiation following a laryngeal attack occurs quickly following the attack; we will assume that these persons do not receive on-demand treatment.	The mean (standard deviation) duration of a fatal laryngeal attack is 4.5 (3.6) hours. ⁸⁵ In Bork et al., 2008, ⁸⁵ whether on-demand therapy had been administered to persons who died following a laryngeal attack was unclear.
All non-fatal moderate and severe acute attacks are treated (varied in sensitivity analysis).	Treatment guidelines and empirical data suggest that moderate and severe attacks are treated. ⁸
Only (and all) severe attacks are treated in the ED.	Treatment guidelines and empirical data suggest that severe attacks are typically treated in the ED. ⁸
Non-severe attacks do not result in ED visits or hospitalizations.	Treatment guidelines and empirical data suggest that non-severe attacks are not typically treated in the ED nor do they result in hospitalizations. ⁸
Mild and moderate attacks last one day; severe attacks last two days. Untreated attacks last an extra day.	Data on the duration of attacks by severity is limited. One study in Italy suggests that there is no difference in the mean duration between mild and moderate attacks, but a trend towards an increased duration of severe attacks. Untreated attacks lasted longer than treated attacks. ⁸⁶
Patients do not discontinue prophylactic therapies over their lifetime.	There is no indication that attack rate declines with age.
Adverse events (AEs) related to these drugs do not lead to substantial incremental costs or disutilities.	There were no serious/treatment-related AEs attributable to the prophylactic therapies in the clinical trials.
We did not model short-term prophylaxis for dental procedures or other episodes.	There is limited data to inform the frequency and or timing of short-term prophylaxis.

Model Inputs

Clinical Inputs

Severity and Anatomical Location of Acute Attacks

Data on the severity and anatomical location of acute attacks were drawn from the Berinert Patient Registry (Table 2 in Riedl 2016¹⁸), ignoring the attacks of unknown intensity. The registry was a multicenter, observational study that was conducted between 2010 and 2014 at 30 US and seven European sites to obtain prospective and retrospective safety and usage data on patients receiving

Berinert. We back-calculated the probability of a laryngeal attack conditional on it being severe as 11.5% in order to match the overall proportion of laryngeal attacks in the Berinert Patient Registry, which was 2.0%.

Table 4.3. Baseline Values for Attack Characteristics

Variable	Value	Source
Severity of Attack (%)		Riedl 2016 ¹⁸
Mild	36.6%	
Moderate	46.2%	
Severe	17.2%	
Severe Attacks that are Laryngeal (%)	11.5%	Riedl 2016 ¹⁸

Treatment Patterns, ED Visits, and Hospitalizations for Acute Attacks

We derived the treatment patterns for acute HAE attacks using data from a survey of US physicians (Figure 7 in Riedl et al., 2015, excluding EDs and hospitals).¹⁷ Specifically, we estimate that 21%, 65%, and 14% of non-severe acute attacks were treated at the physician’s office/outpatient urgent care center, by the patient at home, and by a home nurse, respectively. We assumed that all severe attacks would be treated in the ED setting and that 40.9% of ED visits would result in a hospitalization.⁸⁷

Duration of Acute Attacks

The model assumed that mild and moderate attacks lasted one day, and severe attacks lasted two days. Untreated attacks would last an extra day.⁸⁶ We applied a mean (standard deviation) duration of a fatal laryngeal attack of 4.5 (3.6) hours.⁸⁵

Treatment Effects

Prophylactic therapies reduce the frequency of acute attacks. We obtained treatment effects, measured as the percent reduction in the number of attacks, from the pivotal trials of each of the prophylactic therapies (Table 4.4).

Table 4.4. Treatment Effect Estimates on the Number of Attacks

Drug	Treatment Effect (% Reduction in Number of Attacks)	Source
Cinryze	50.5%	Zuraw et al., 2010 ⁴¹
Haegarda	84.0%	Longhurst et al., 2017 ²⁹
Lanadelumab	86.9%	Banerji et al., 2017 ³⁰

The COMPACT study showed that Haegarda may alter the distribution of attack severity. To account for this change in severity distribution, we calculated multinomial logit estimates of the effect of Haegarda prophylaxis using aggregate data on the distribution of attack severity comparing patients receiving Haegarda and those receiving placebo (Table 4.5).

Table 4.5. Treatment Effect Estimates on the Severity of Attacks for Haegarda

	Placebo, Number of Attacks (%)	Treated, Number of Attacks (%)	Multinomial Logit Estimates	
			Constant, estimate (standard error)	Treated, estimate (standard error)
Mild	123 (26%)	30 (42%)	-	-
Moderate	243 (52%)	34 (48%)	0.68 (0.11)	-0.56 (0.27)
Severe	106 (22%)	7 (10%)	-0.15 (0.13)	-1.31 (0.44)

To apply this treatment effect, we re-calibrated the constant in the multinomial logit estimates to reflect the baseline (no prophylaxis) severity distribution in our model, applied the treatment effect, and calculated the new distribution of severity of attacks in patients who received prophylaxis. In our base-case analysis, we applied this treatment effect only to Haegarda. Analogous data were not available for Cinryze and lanadelumab; however, we explore the potential impact of a similar effect for both in scenario analyses.

Mortality Due to HAE Attacks

We assumed that only laryngeal attacks could be fatal. In a cohort of approximately 1,000 patients diagnosed with HAE 1/2 in Italy, followed between 1973-2013, there were five deaths from asphyxiation due to laryngeal attack in patients who receive on-demand therapy.³⁵ We used these data to estimate the monthly probability of death from a laryngeal attack as 0.0022%, assuming a constant annual rate of inclusion in the cohort, and that approximately 2% (17.2% times 11.5%) of acute attacks were laryngeal (Table 4.3).

Utilities

Our approach to modelling the utility benefits of long-term prophylaxis accounted for a proportion of patients who never experience acute attacks when on long-term prophylaxis (Tables 4.6 and 4.7). Utility estimates were derived from a study in Sweden that utilized the EuroQoL 5D (EQ-5D) to ascertain health-related quality of life among HAE patients experiencing acute attacks.³² Patients completed EQ-5D-5L (five-level) for both the attack-free state (EQ-5D today), and the last HAE attack (EQ-5D attack), and authors collected data on age, sex, and other variables such as attack location and severity. Patient EQ-5D-5L scores were valued using a community-based sample, with the UK crosswalk value set from the EQ5D-3L to the EQ5D-5L used to derive the utility scores. The estimated mean \pm standard error EQ-5D today (i.e., “attack free”) utility score was 0.825 ± 0.207 . Increasing attack frequency (-0.0043 per attack, $p < 0.001$) and greater age (-0.02205 per 10 years of

age, $p < 0.001$) had significant influences on the EQ-5D today score. We used these estimates to construct a baseline utility function that was dependent on age and number of attacks.

$$U_{today} = 0.825 - 0.02205 * age - 0.0043 * \#attacks$$

The estimates from this function were used as the baseline utility for patients who experience acute attacks. For patients who are completely attack-free, the “number of attacks” term ($\#attacks$) was set to 0, such that utility was only a decreasing function of age.

The difference between the EQ-5D today and EQ-5D attack scores of the latest attack were 0.070 for mild, 0.369 for moderate, and 0.486 for severe attacks (Figure 2 in Nordenfelt et al., 2014).³² We used these as the disutilities associated with mild, moderate, and severe attacks, respectively.

Table 4.6. Proportion Attack-Free on Prophylaxis

Drug	% Attack Free*	Source
Cinryze	18.2%	Zuraw et al., 2010 ⁴¹
Haegarda	40.0%	Longhurst et al., 2017 ²⁹
Lanadelumab	44.0%	Banerji et al., 2017 ³⁰

*Values in this column represent the trial-reported proportion of patients who were attack free.

Table 4.7. Utility Estimates and Functions

	Utility Value	Source
EQ-5D Today Utility*	$U_{today} = 0.825 - 0.02205 * age - 0.0043 * \#attacks$	Nordenfelt et al. ³²
EQ-5D Attack Disutility		
Mild	-0.070	Nordenfelt et al. ³²
Moderate	-0.369	Nordenfelt et al. ³²
Severe	-0.486	Nordenfelt et al. ³²

* $\#attacks$ = the mean attacks per month. For the proportion who are attack-free, $\#attacks = 0$; for the proportion of patients experiencing attacks, $\#attacks$ is upweighted to reflect the mean number of attacks in that subset.

Drug/Therapy Utilization

We assumed that prophylactic therapies were taken on a life-long basis. We also assumed that during treatment with on-demand therapy for acute attacks, doses of prophylactic therapy were delayed. The duration of delay was equal to the mean length of an acute attack, totaled over the mean number of attacks in a cycle. The dosing regimens and schedules are shown in Table 4.8.

Table 4.8. Drug Utilization Parameters

Drug	Dosing
Cinryze	1,000 IU twice a week
Haegarda	60 IU/kg twice a week
Lanadelumab	300 mg every two weeks

Adverse Events

We did not include adverse events in our model because there were no serious or clinically relevant adverse events attributable to any of the prophylactic therapies in the clinical trials.

Cost Inputs

Where necessary, all costs were inflated to 2018 US dollars. Health care costs were inflated using the Personal Health Care (PHC) index up to 2016,⁸⁸ and the Personal Consumption Expenditure (PCE) price index from 2016 to 2018.⁸⁹ Non-health care costs were inflated using the general Consumer Price Index.⁹⁰

Prophylactic Drug Acquisition Costs

Prophylactic drug cost inputs are shown in Table 4.9. We used the Federal Supply Schedule (FSS) price (Big 4 prices where available or FSS price where the Big 4 price was not available) per dose unit for subcutaneously administered drugs and self-administered doses of intravenously administered drugs. For non-self-administered doses of intravenous drugs, because the drug is not being dispensed directly to the patient, we used the average sales price (ASP) plus a 9% markup representing the mean markup for units administered in physicians' office, home infusion, and hospital outpatient settings (Table 4.9).

Table 4.9. Prophylactic Drug Cost Inputs

Intervention	Administration	Unit	Big 4 or FSS Price per Package/Dose*	ASP per Unit/Dose†
Cinryze	IV	500 IU	\$2,012	\$3,049
Haegarda	SC	2,000 IU	\$1,393	-
Haegarda	SC	3,000 IU	\$2,090	-
Lanadelumab	SC	300 mg	\$16,520	-

*Big 4 or Federal Supply Schedule price as of October 1, 2018.

†Average Sales Price as of June 13, 2018, plus 9% markup for units administered in physicians' office, home infusion, and hospital outpatient settings.

For Haegarda, which is dosed according to weight, we used gender-specific weight distributions (i.e., mean and standard deviation) to calculate the average number of 2,000 IU and 3,000 IU vials, accounting for wastage and selecting the vial combination with minimum cost from all possible vial combinations

Administration and Monitoring Costs for Prophylactic Drugs

For lanadelumab and Haegarda, which are administered subcutaneously, only the first dose was assumed to be administered in a clinic. We applied the cost of a physician office visit of \$80 (CPT 99214) and the cost of subcutaneous administration of \$20.88 (CPT code 96372). No additional

training costs were included as these were assumed to be covered by the drug manufacturers.⁹¹ Subsequent doses were self-administered.

For Cinryze, which is administered intravenously, we assumed that the costs of training for self-administration are covered by the drug manufacturer,^{92,93} and therefore excluded any costs for training. Based on data from the Berinert registry, we estimated that 95% of patients would self-administer their IV therapies.¹⁸ For the 5% who cannot or choose not to self-administer, we applied a physician visit and drug administration costs in each cycle of the model.

Health Care Utilization Costs for On-Demand Treatment

Direct costs of acute attacks included drug costs, costs of a home nurse (\$177), and physician office administration of on-demand treatment (\$262) from Graham et al., 2017,⁹⁴ and costs of ED visits (\$1,479, 95% CI: \$1,028-\$1,929) and hospitalizations (\$4,760, 95% CI: \$3,612-\$5,907) from Zilberberg et al.^{87,95}

Therapeutic options for on-demand treatment of acute attacks were Berinert (20 IU/kg), ecallantide (Kalbitor 30 mg), icatibant (Firazyr 30 mg), and Ruconest (50 IU/kg). We computed the average costs per attack in each treatment setting as the cost of these drugs (Table 4.10) weighted by the proportion of attacks treated with each drug in each treatment setting. Estimates of the proportion of attacks requiring an extra dose for each drug were 1.9% for Berinert,¹⁰ 12% for Kalbitor,⁹⁶ 12.7% for Firazyr,¹⁰ and 6.6% for Ruconest.^{97,98} We assumed that equal proportions of attacks were treated with each drug in each treatment setting, noting that Kalbitor is not approved for home or self-administration.

Table 4.10. Parameters for Costs of On-Demand Treatment for Acute Attacks

	Berinert	Kalbitor	Firazyr	Ruconest
Dose Schedule	20 IU/kg	30 mg	30 mg	50 IU/kg
FSS per Dose*	\$4,174	\$11,174	\$7,178	\$10,112
ASP per Dose†	\$9,807	\$15,594	\$7,178	\$15,164
% Requiring Extra Dose	1.9%	12.0%	12.7%	6.6%

*Federal Supply Schedule or Big 4 price as of September 15, 2018.

†Average sales price as of June 13, 2018, plus 9% markup for administration in physicians' office, home infusion, and hospital outpatient settings.

In Bork et al., 2012⁸⁵, 31% of patients with fatal laryngeal attacks did not receive any emergency life-saving care. We assumed that these patients died before arriving at the ED. Of the remainder (69%), 40% received an emergency cricothyrotomy and intubation was attempted in the rest. Artificial respiration was attempted in 40% of patients following a cricothyrotomy (50% for more than 96 hours) and 27% of those who were intubated (25% for more than 96 hours). Based on these proportions, in addition to the cost of an ED visit, we applied costs of a cricothyrotomy of

\$347 (CPT 31605), costs of intubation of \$146 (CPT 31500), and artificial respiration costs of \$14,809 for less than 96 hours (DRG 208) and \$32,709 for more than 96 hours (DRG 207).

Adverse Event Costs

There were no serious or clinically-relevant AEs attributable to any of the prophylactic therapies in the clinical trials.

Productivity Costs

Indirect costs (including missed work, child care, and travel) for acute attacks (by severity) were obtained from Wilson et al., 2010⁹⁹: \$959 for mild, \$4,048 for moderate, and \$6,656 for severe attacks, after adjustment for the mean number of attacks (26.9).

Sensitivity Analyses

We conducted one-way sensitivity analyses to identify the key drivers of model outcomes, using available measures of parameter uncertainty (i.e., standard errors) or reasonable ranges for each input described in the model inputs section.

Probabilistic sensitivity analyses were performed by jointly varying all model parameters over 5,000 simulations, then calculating 95% credible range estimates for each model outcome. We used normal distributions for age and weight, beta distributions for binary proportions and utilities, Dirichlet distribution for multinomial categorical variables, gamma distributions for costs, and log-normal distributions for the baseline attack rate and percentage mean reductions in the attack rate. We calculated the probability that each intervention would be cost-effective relative to no prophylaxis at willingness-to-pay (WTP) thresholds of \$50,000, \$100,000, \$150,000, \$200,000, and \$250,000 per QALY.

Scenario Analyses

We conducted a number of scenario analyses. First, we estimated costs, outcomes, and incremental cost-effectiveness ratios from a modified societal perspective (i.e., including direct and indirect costs). We varied the baseline attack rate from one to ten attacks per month, holding all other parameters constant to examine the impact on the incremental cost-effectiveness ratios. We estimated, for each intervention, the baseline attack rate that would yield incremental cost-effectiveness ratios in line with the following WTP thresholds: \$50,000, \$100,000, \$150,000, \$250,000, and \$500,000 per QALY gained.

Additionally, we performed threshold analyses by systematically altering the price of the interventions to estimate the maximum prices that would correspond to WTP thresholds of \$50,000, \$100,000, \$150,000, \$200,000, \$300,000, and \$500,000 per QALY. We also estimated

incremental cost effectiveness ratios applying wholesale acquisition costs (WAC) for all drugs in all administration settings.

Data on the impact of Cinryze and lanadelumab on severity were either not available or were in a format that would not allow us to consistently apply them to the baseline distribution of severity in the model. However, we performed scenario analyses in which we assumed that these drugs had effects on severity equivalent to that observed with Haegarda.

Lanadelumab's label states that "a dosing interval of 300 mg every 4 weeks is also effective and may be considered if the patient is well-controlled (e.g., attack free) for more than 6 months."¹⁰⁰ We performed a scenario analysis modeling reduction in the dosing frequency to every four weeks in patients who were attack free on lanadelumab for six months. In the HELP study, 44% of patients on the every two week regimen and 31% of patients on the every four week regimen achieved attack-free status. Therefore, at six months and beyond, we assumed monthly dosing would be attempted in 44% of patients, with only 31% (70% of the patients who attempted dose frequency reduction) remaining attack free and on every four week dosing. We also performed a threshold analysis to calculate the proportion of patients attack free on every two week dosing that would need to successfully switch to every four week dosing in order to achieve incremental cost-effectiveness thresholds of \$150,000, \$100,000, and \$50,000 per QALY, and for lanadelumab to become dominant.

Model Validation

We used several approaches to validate the model. First, we provided preliminary methods and results to manufacturers and clinical experts. Based on feedback from these groups, we refined the data inputs used in the model as needed. Second, we varied model input parameters to evaluate face validity of changes in results. We verified the model calculations using internal reviewers.

4.3 Results

Base Case Results

The base-case results are shown in Tables 4.11 and 4.12. The average total lifetime direct costs for no prophylaxis was \$9,953,000. This included \$9,205,000 in on-demand drug costs for acute treatment and \$748,000 in other acute treatment costs (including administration costs, ED visits, hospitalizations, and emergency procedures for those with laryngeal attacks). The average lifetime direct costs for patients receiving prophylaxis ranged from \$10,343,000 for patients receiving Haegarda to \$14,396,000 for patients receiving Cinryze. Prophylactic drug costs ranged from \$8,897,000 (Haegarda) to \$9,970,000 (lanadelumab). On-demand drug costs for acute treatment ranged from \$1,206,000 for patients receiving lanadelumab to \$4,557,000 for patients receiving

Cinryze), and other acute treatment costs ranged from \$55,000 for patients receiving Haegarda to \$370,000 for patients receiving Cinryze.

Lifetime QALYs were 17.47 without prophylaxis and ranged from 18.21 for patients receiving Cinryze to 18.66 for patients receiving lanadelumab with prophylaxis leading to incremental cost-effectiveness ratios ranging from \$328,000 for patients receiving Haegarda to \$5,954,000/QALY for patients receiving Cinryze from a US health system perspective. Patients were estimated to experience 1,703 acute attacks over a lifetime without long-term prophylaxis, and between 223 for patients receiving lanadelumab and 843 for patients receiving Cinryze, leading to incremental costs per attack avoided between \$273 for patients receiving Haegarda and \$5,168 for patients receiving Cinryze.

Table 4.11. Results for the Base-Case Analysis

	No Prophylaxis	Cinryze	Haegarda	Lanadelumab
Total Costs – US Health System Perspective	\$9,953,000	\$14,396,000	\$10,343,000	\$11,274,000
Prophylaxis Drug Costs	\$0	\$9,469,000	\$8,897,000	\$9,970,000
Acute Treatment Costs	\$9,953,000	\$4,927,000	\$1,446,000	\$1,304,000
Acute Treatment Costs (Drugs)	\$9,205,000	\$4,557,000	\$1,391,000	\$1,206,000
Acute Treatment Costs (Other services)	\$748,000	\$370,000	\$55,000	\$98,000
LYs	23.55	23.55	23.55	23.55
QALYs	17.47	18.21	18.65	18.66
# of Attacks	1,703	843	273	223

*Costs are rounded to the nearest \$1,000.

Table 4.12. Incremental Results versus No Prophylaxis for the Base-Case Analysis

	Cinryze	Haegarda	Lanadelumab
Total Costs – US Health System Perspective	\$4,443,000	\$390,000	\$1,321,000
Prophylaxis Drug Costs	\$9,469,000	\$8,897,000	\$9,970,000
Acute Treatment Costs	-\$5,026,000	-\$8,507,000	-\$8,648,000
Acute Treatment Costs (Drugs)	-\$4,648,000	-\$7,814,000	-\$7,999,000
Acute Treatment Costs (Other Services)	-\$378,000	-\$693,000	-\$650,000
LYs Gained	0.00	0.00	0.00
QALYs Gained	0.75	1.19	1.19
# of Attacks Avoided	860	1,430	1,480
ICER – US Health System Perspective	\$5,954,000	\$328,000	\$1,108,000
\$/Attack Avoided - US Health System Perspective	\$5,168	\$273	\$892

*Incremental cost-effectiveness ratios are rounded to the nearest \$1,000; incremental cost-effectiveness ratios are rounded to the nearest \$10,000 when over \$1 million.

Sensitivity Analysis Results

To demonstrate effects of uncertainty on both costs and health outcomes, we varied input parameters using available measures of parameter uncertainty (i.e., standard errors) or reasonable ranges to evaluate changes in cost per additional QALY for all model input parameters. We found that prophylactic drug acquisition costs, baseline attack rate, and the treatment effect (% mean reduction in attack frequency) in most cases had the largest impact on the incremental cost-effectiveness ratio (Figure 4.3).

Figure 4.3. Tornado Diagrams for One-Way Sensitivity Analyses of Prophylactic Interventions versus No Prophylaxis from the US Health System Perspective Showing the Top 10 Influential Variables on the Incremental Cost-Effectiveness Ratio

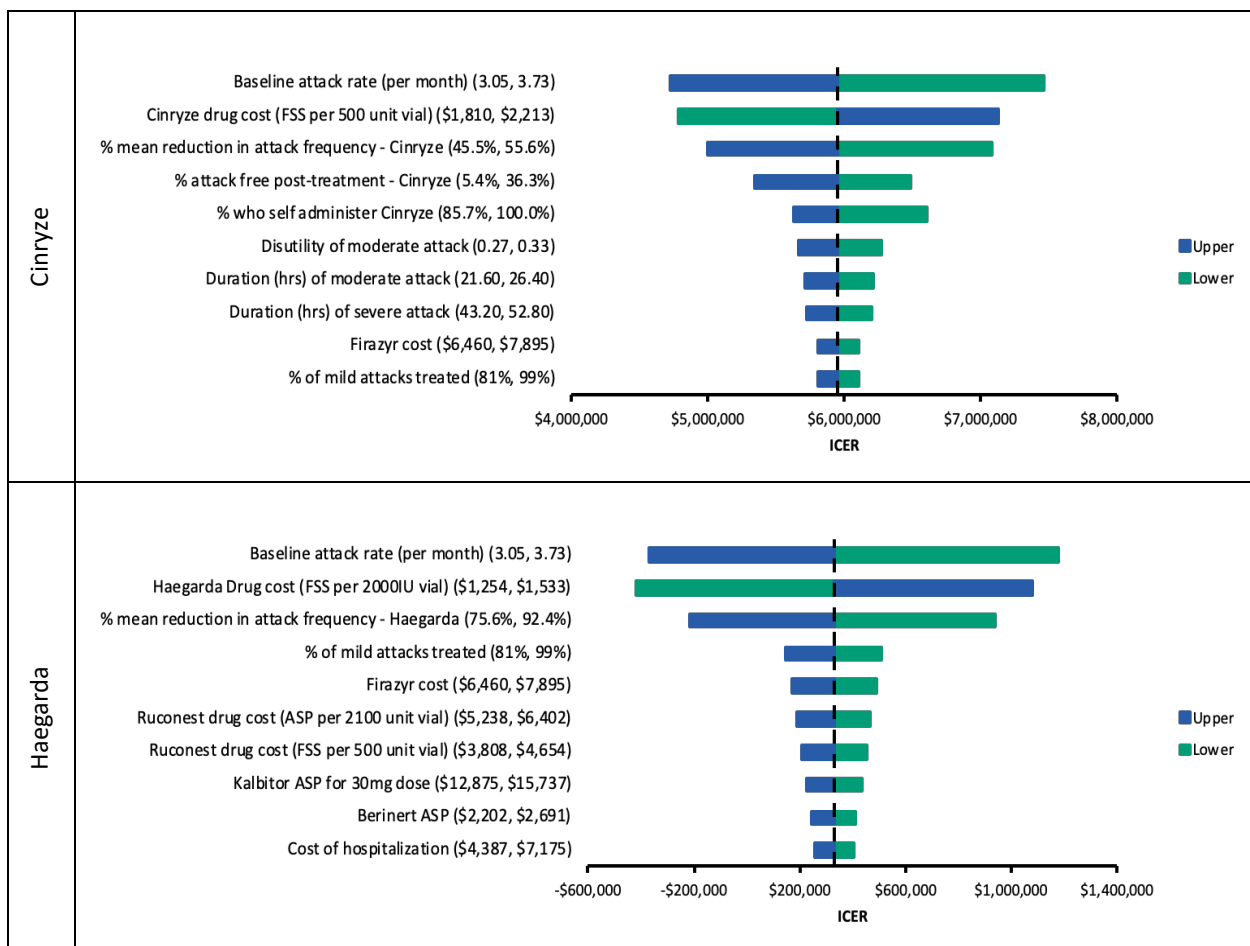

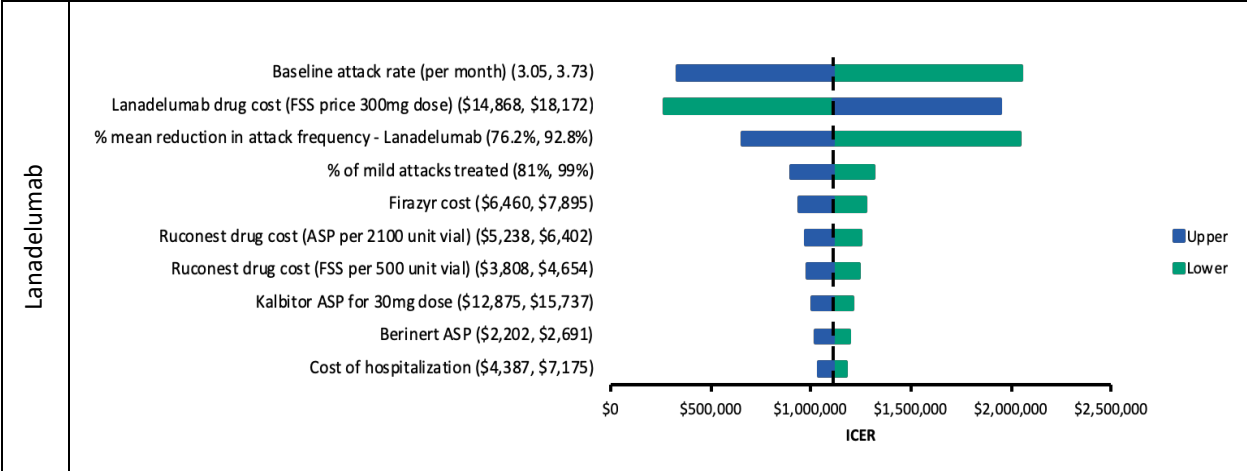

Results of the probabilistic sensitivity analysis are shown in Table 4.13 and Appendix Figure E1. Over 5,000 Monte Carlo simulations, the probability that Haegarda and lanadelumab met cost-effectiveness thresholds from \$50,000 to \$500,000 per QALY ranged from 30% to 62%, and 3% to 14%, respectively.

Table 4.13. Probabilistic Sensitivity Analysis Results: Proportion of Simulations in which Prophylaxis was Cost-Effective from the US Health Care Sector Perspective at Different Willingness-to-Pay Thresholds

	Cost-Effective at \$50,000 per QALY	Cost-Effective at \$100,000 per QALY	Cost-Effective at \$150,000 per QALY	Cost-Effective at \$250,000 per QALY	Cost-Effective at \$500,000 per QALY
Cinryze	0%	0%	0%	0%	0%
Haegarda	30%	33%	36%	43%	62%
Lanadelumab	3%	4%	5%	6%	14%

Scenario Analyses Results

Modified Societal Perspective

Detailed results from analyses taking a modified societal perspective can be found in Appendix Tables E2 and E3. The average lifetime indirect cost for no prophylaxis was \$151,000; and indirect costs associated with prophylaxis ranged from \$18,000 for patients receiving Haegarda to \$75,000 for patients receiving Cinryze. Incremental cost-effectiveness ratios ranged from \$216,000 for patients receiving Haegarda to \$5,852,000 for patients receiving Cinryze. Incremental costs per attack avoided ranged from \$180 for patients receiving Haegarda to \$5,079 for patients receiving Cinryze.

Threshold Analysis on Baseline Attack Rate

The impact of changes in baseline monthly attack rate on incremental cost-effectiveness ratios for each intervention are shown in Figure 4.4 and Table 4.14. The baseline monthly attack rates that would be required to reach cost-effectiveness thresholds of \$50,000 to \$500,000 per QALY ranged between 5.99 to 5.66 for Cinryze, 3.52 to 3.31 for Haegarda, and 3.87 to 3.65 for lanadelumab.

Table 4.14. Results of Threshold Analysis on Baseline Attack Rate

	Attack Rate to Achieve \$50,000 per QALY	Attack Rate to Achieve \$100,000 per QALY	Attack Rate to Achieve \$150,000 per QALY	Attack Rate to Achieve \$250,000 per QALY	Attack Rate to Achieve \$500,000 per QALY
Cinryze	5.99	5.95	5.92	5.84	5.66
Haegarda	3.52	3.49	3.47	3.43	3.32
Lanadelumab	3.87	3.85	3.82	3.77	3.65

Figure 4.4. Impact of Baseline Attack Rate on Incremental Cost-Effectiveness Ratios of Prophylactic Interventions versus No Prophylaxis from the US Health System Perspective

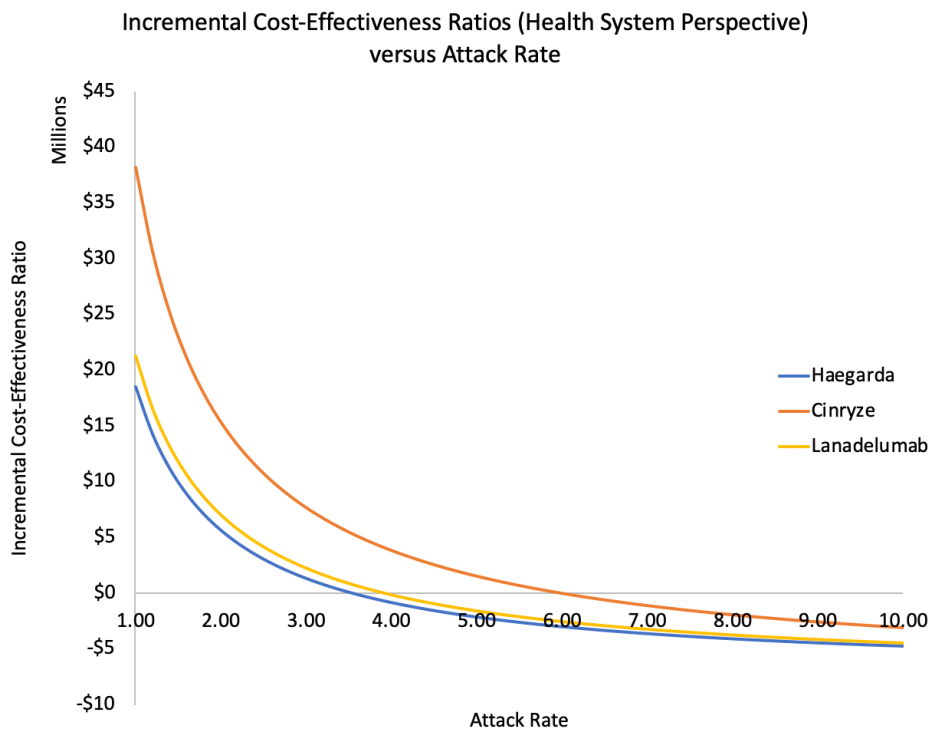

Effects on Attack Severity

When we assumed that other Cinryze and lanadelumab had similar effects on attack severity as Haegarda, we found that total direct costs were \$13,991,000 and \$11,166,000 for Cinryze and

lanadelumab, respectively. Total QALYs were 18.33 and 18.68, resulting in incremental cost-effectiveness ratios of \$4,646,000 and \$1,000,000 per QALY from a health care system perspective for Cinryze and lanadelumab, respectively.

Threshold Analysis on Prices

Threshold prices corresponding to cost per QALY thresholds ranging from \$50,000 to \$500,000 are shown in Table 4.15. The prices ranged from \$1,096 to \$1,169 for 500 units of Cinryze, \$1,341 to \$1,425 for 2,000 units of Haegarda, and \$14,431 to \$15,319 for 300 mg of lanadelumab.

Table 4.15. Threshold Analysis Results

	List price	Net Price per Package	Price to Achieve \$50,000 per QALY	Price to Achieve \$100,000 per QALY	Price to Achieve \$150,000 per QALY	Price to Achieve \$200,000 per QALY	Price to Achieve \$300,000 per QALY	Price to Achieve \$500,000 per QALY
Cinryze (500 IU)	\$2,759	\$2,012	\$1,096	\$1,104	\$1,112	\$1,120	\$1,137	\$1,169
Haegarda (2,000 IU)	\$1,880	\$1,393	\$1,341	\$1,351	\$1,360	\$1,369	\$1,388	\$1,425
Lanadelumab (300 mg)	\$22,070	\$16,520	\$14,431	\$14,530	\$14,628	\$14,727	\$14,924	\$15,319

Incremental Cost-Effectiveness Ratios at Wholesale Acquisition Costs

Detailed results from analyses applying the WAC can be found in Appendix Tables E4 and E5. The average lifetime direct cost for no prophylaxis was \$12,515,000. Direct costs associated with prophylaxis ranged from \$13,898,000 for patients receiving Haegarda to \$18,863,000 for patients receiving Cinryze. Incremental cost-effectiveness ratios ranged from \$1,165,000 for patients receiving Haegarda to \$8,507,000 for patients receiving Cinryze. Incremental costs per attack avoided ranged from \$967 for patients receiving Haegarda to \$7,383 for patients receiving Cinryze.

Reduced Dosing Frequency among Attack-Free Patients on Lanadelumab

In the scenario analysis in which every four week dosing of lanadelumab was attempted in all attack free patients who were on every two week dosing, the total direct costs were \$9,751,000, with \$8,447,000 in prophylaxis drug costs, \$1,304,000 in acute treatment costs (\$1,206,000 in on-demand drug costs and \$98,000 in other acute treatment costs), and \$20,000 in indirect costs. QALYs were 18.66 and patients were expected to experience 223 attacks. Lanadelumab would be dominant (i.e., lower costs and higher QALYs) over no prophylaxis from both health system and modified societal perspectives. The threshold proportion of patients switching to every four week dosing to achieve incremental cost-effectiveness thresholds of \$150,000, \$100,000, \$50,000 per

QALY, and for lanadelumab to become dominant, were 75.0%, 78.9%, 82.8% and 86.7% respectively.

Model Validation

Model validation followed standard practices in the field. We tested all mathematical functions in the model to ensure they were consistent with the report (and supplemental Appendix materials). We also conducted sensitivity analyses with null and maximum input values. The model was producing findings consistent with expectations. Further, independent modelers tested the mathematical functions in the model as well as the specific inputs and corresponding outputs.

Prior Published Evidence on Costs and Cost-Effectiveness

We identified one prior cost-effectiveness model of long-term prophylaxis in HAE patients with ≥ 2 attacks per month, from a US third party payer perspective.^{94,101} Results from this manufacturer-funded model comparing Haegarda to Cinryze have only been presented at two conferences in 2017, so a detailed comparison to the present analysis is difficult. The model by Graham et al. estimated that Haegarda would result in 89% fewer attacks and be cost-saving compared to Cinryze over a one-year time horizon. While our analysis did not directly compare these drugs to each other (only to no prophylaxis), we did estimate more attacks avoided and lower total health care costs for Haegarda than for Cinryze over a lifetime horizon. However, we could not directly compare the results from this analysis to those from ours, given the different time horizons and comparators involved. Full results for no prophylaxis were not presented in the Graham et al. posters. Other economic models of HAE from a UK,¹⁰² Polish,¹⁰³ and Brazilian¹⁰⁴ perspective have been concerned with treatments for acute attacks rather than for prophylaxis, and had much shorter time horizons (e.g., the duration of an acute attack or one year).

4.4 Summary and Comment

Limitations

There are several important limitations to our analysis. Our estimates of long-term comparative clinical effectiveness of prophylaxis are uncertain due to a lack of data on the natural history of attack rates over patients' lifetimes and by the small sample sizes and the short duration of the available clinical trials. Our analysis was also limited by inadequate data and a lack of clinical guideline standards by which to estimate the baseline attack rates for patient populations that will be considered for prophylactic therapy. Our base-case analysis was able to capture the potential of prophylaxis to reduce the severity of subsequent attacks only for Haegarda, because similar data were not available for the Cinryze or lanadelumab. We therefore ran scenario analyses that assumed Cinryze and lanadelumab had a similar impact on severity. The analysis revealed only

modest impacts on the overall results. Finally, because US-specific data on utilities and HAE mortality were not available, we used estimates from European studies.

Conclusions

Prophylactic treatment for patients with HAE 1/2 improves health outcomes by reducing the number of acute attacks. In the base case analyses, Cinryze (\$5,954,000 per QALY), Haegarda (\$328,000 per QALY), and lanadelumab (\$1,108,000 per QALY) all far exceeded cost-effectiveness thresholds of \$100,000 to \$150,000 per QALY.

The overall cost-effectiveness of prophylactic treatment is dependent upon the balance between the costs of therapies used for prophylaxis and the costs of on-demand treatment that can be avoided by reducing acute attacks. This effect is magnified by the high costs of both prophylactic and on-demand therapies and the fact that patients receive treatment over their remaining lifetime. The economic modeling results are therefore highly sensitive to assumptions made about variables such as the baseline rate of acute attacks and the likelihood that patients will switch dosing schedules over time for prophylactic therapy. For example, the cost-effectiveness of prophylactic treatment with Haegarda varied from \$50,000 per QALY for patients with 3.52 acute attacks per month to \$500,000 per QALY for patients with a baseline of 3.32 attacks per month. Similarly, despite a baseline cost-effectiveness for lanadelumab of more than \$1 million per QALY when administered every two weeks, if 86.7% of patients who are attack free for six months switch to every four week dosing, which the FDA label says “may be considered,” then prophylactic treatment with lanadelumab becomes dominant (improves outcomes and saves costs). Cinryze, however, appeared unlikely to be cost-effective at usual thresholds across a range of assumptions.

In summary, at current drug prices, prophylactic treatment for HAE 1/2 does not meet traditional cost-effectiveness thresholds within the health care system perspective under our base case assumptions. However, there is significant uncertainty in key model assumptions, demonstrated by widely varying cost-effectiveness findings in univariate and multivariable sensitivity analyses.

5. Potential Other Benefits and Contextual Considerations

Our reviews seek to provide information on potential other benefits offered by the intervention to the individual patient, caregivers, the delivery system, other patients, or the public that would not have been considered as part of the evidence on comparative clinical effectiveness. These general elements are listed in the table below, and the subsequent text provides detail about the elements that are applicable to the comparison of C1-INHs and lanadelumab for long-term prophylactic therapy to on-demand therapy only.

Table 5.1. Potential Other Benefits or Contextual Considerations

Potential Other Benefits
This intervention offers reduced complexity that will significantly improve patient outcomes.
This intervention will reduce important health disparities across racial, ethnic, gender, socio-economic, or regional categories.
This intervention will significantly reduce caregiver or broader family burden.
This intervention offers a novel mechanism of action or approach that will allow successful treatment of many patients for whom other available treatments have failed.
This intervention will have a significant impact on improving return to work and/or overall productivity.
This intervention will have a significant positive impact outside the family, including on schools and/or communities.
This intervention will have a significant impact on the entire “infrastructure” of care, including effects on screening for affected patients, on the sensitization of clinicians, and on the dissemination of understanding about the condition, that may revolutionize how patients are cared for in many ways that extend beyond the treatment itself.
Other important benefits or disadvantages that should have an important role in judgments of the value of this intervention.
Contextual Considerations
This intervention is intended for the care of individuals with a condition of particularly high severity in terms of impact on length of life and/or quality of life.
This intervention is intended for the care of individuals with a condition that represents a particularly high lifetime burden of illness.
This intervention is the first to offer any improvement for patients with this condition.
Compared to on-demand treatment only, there is significant uncertainty about the long-term risk of serious side effects of this intervention.
Compared to on-demand treatment only, there is significant uncertainty about the magnitude or durability of the long-term benefits of this intervention.
There are additional contextual considerations that should have an important role in judgments of the value of this intervention.

5.1 Potential Other Benefits

Based on ICER's adaptation of the value framework for rare diseases, use of C1-INHs and lanadelumab for long-term prophylaxis of HAE 1/2 have a number of potential other benefits.

- The availability of effective drugs for long-term prophylaxis of HAE attacks may result in benefits not only for patients, but for caregivers and society, as discussed below.
 - HAE patients face significant uncertainty regarding the onset and pattern of acute attacks. The decrease in attack rate – and, in some cases, the virtual elimination of acute attacks – is likely to decrease anxiety and stress about future attacks, allow for more freedom in planning events and travel, less restriction on participating in sports, hobbies, or social activities, improve work and school productivity and improve career advancement/educational attainment. Caregivers will also have less emotional burden.^{22,23}
 - HAE attacks impair both patients' and caregivers' ability to work or go to school and their productivity. Reduction in acute HAE attacks may decrease absenteeism and impairment at work and could increase the patient or caregiver's ability to find and maintain employment and improve the chances of career advancement. For patients who are in school, less missed school could lead to higher levels of educational attainment. Schools and communities are likely to benefit from such improvements.²²
- The subcutaneous options for prophylaxis (Haegarda and lanadelumab) may decrease the burden and complexity of administration, including those associated with on-demand intravenous therapy for acute attacks (e.g., fewer complications due to repeated infusion therapy or use of ports). Patients report that the ability to self-administer therapy may lead to increased feelings of control over the disease, a greater ability to lead a normal life, and a decreased burden on caregivers.
- In areas where access to health care or access to on-demand therapy is limited, long-term prophylactic therapy could potentially be life-saving.
- Lanadelumab offers a novel mechanism of action from C1-INHs and may benefit patients whose disease is not optimally controlled on C1-INHs.

5.2 Contextual Considerations

There are a number of contextual considerations relevant to patients with HAE 1/2 who are treated with long-term prophylactic therapy:

- HAE is a lifelong disease that is potentially life-threatening and results in substantial decrement in quality of life.

- The availability of effective therapies to decrease acute attacks may result in increased awareness of the disease, which in turn may result in increased efforts to accurately diagnose HAE earlier in the disease course, saving patients years of suffering.
- There are significant uncertainties about the long-term safety and efficacy of lanadelumab, a monoclonal antibody inhibiting plasma kallikrein that has the potential to affect angiogenesis, for example, compared with C1-INHs, which replace a physiologic deficiency. New biologic therapies frequently are found to have safety concerns in the years after they are introduced that were not detected in pre-approval trials.³¹

6. Value-Based Price Benchmarks

Annual value-based benchmark prices of the drugs for prophylactic treatment of HAE 1/2 patients are presented in Table 6.1. As noted in the ICER methods document (<https://icer-review.org/material/final-vaf-2017-2019/>), the value-based benchmark price for a therapy is defined as the price range that would achieve incremental cost-effectiveness ratios between \$100,000 and \$150,000 per QALY gained. For Cinryze, price discounts of approximately 60% from the list price (WAC) would be required to reach the \$100,000 to \$150,000 per QALY threshold prices. Discounts from the list price to reach the \$100,000 to \$150,000 per QALY threshold prices would be approximately 28% for Haegarda, and approximately 34% for lanadelumab.

Table 6.1. Value-Based Benchmark Prices for HAE 1/2 Prophylactic Therapies

	List Price	Net Price	Price to Achieve \$100,000 per QALY	Price to Achieve \$150,000 per QALY	Discount from List Price to Reach Threshold Prices
Cinryze*	\$539,670	\$401,512	\$215,993	\$217,577	59.7% to 60.0%
Haegarda	\$509,792	\$377,786	\$366,280	\$368,802	27.7% to 28.2%
Lanadelumab	\$565,557	\$423,344	\$372,327	\$374,857	33.7% to 34.2%

QALY: quality-adjusted life year

*Weighted average of 95.2% self-administered and 4.8% physician-administered.

7. Potential Budget Impact

7.1 Overview

We used the cost-effectiveness model to estimate the potential total budgetary impact of lanadelumab in HAE 1/2 patients in the US, at the annual wholesale acquisition cost (WAC) of \$565,557, the net price of \$423,344, and the cost-effectiveness threshold prices at \$50,000, \$100,000, and \$150,000 per QALY.

7.2 Methods

We used results from the same model employed for the cost-effectiveness analyses to estimate total potential budget impact. Potential budget impact was defined as the total differential cost of using each new therapy rather than relevant existing therapy for the treated population, calculated as differential health care costs (including drug costs) minus any offsets in these costs from averted health care events. All costs were undiscounted and estimated over a five-year time horizon. The five-year timeframe was of primary interest, given the potential for cost offsets to accrue over time and to allow a more realistic impact on the number of patients treated with the new therapy.

The potential budget impact analysis included the candidate population eligible for treatment: patients in the US with HAE 1/2 who are candidates for long-term prophylactic treatment. To estimate the size of the potential candidate population, we used an estimate of one per 50,000 individuals with HAE 1/2 in the US population.⁴ Then, we estimated the size of the US population for years 2018 to 2022 using population projection data published by the US Census Bureau.³³ When applied to the US population in the next five years, it would put the US prevalence at 6,690 individuals. In recognition of the fact that not all patients with HAE 1/2 are considered candidates for long-term prophylactic treatment, we assumed that only one-third of the patients were eligible for prophylaxis based on expert opinion, resulting in approximately 2,230 patients eligible for prophylactic treatment. We assumed equal uptake over five years, which translated to 446 patients initiating treatment each year.

ICER's methods for estimating potential budget impact are described in detail elsewhere and have recently been updated.¹⁰⁵ The intent of our revised approach to budgetary impact is to document the percentage of patients that could be treated at selected prices without crossing a budget impact threshold that is aligned with overall growth in the US economy.

Briefly, we evaluate a new drug that would take market share from one or more drugs and calculate the blended budget impact associated with displacing use of existing therapies with the new intervention. In this analysis, we assumed that most of the patients currently eligible for prophylaxis would be using the prophylactic treatments which are already on the market (i.e.,

Haegarda and Cinryze). A recent survey of HAE patients reported that 2% of the patients who had tried prophylaxis were very dissatisfied with that treatment. We therefore assumed that 2% of patients initiating treatment with lanadelumab would not be on long-term prophylaxis.⁹ We assumed that the other 98% of patients taking a new prophylactic treatment (i.e., lanadelumab) would consist equally of patients who would otherwise have taken either Haegarda (49%) or Cinryze (49%).

Using this approach to estimate potential budget impact, we then compared our estimates to an updated budget impact threshold that represents a potential trigger for policy mechanisms to improve affordability, such as changes to pricing, payment, or patient eligibility. As described in ICER’s methods presentation (<https://icer-review.org/methodology/icers-methods/icer-value-assessment-framework/>), this threshold is based on an underlying assumption that health care costs should not grow much faster than growth in the overall national economy. From this foundational assumption, our potential budget impact threshold is derived using an estimate of growth in US gross domestic product (GDP) +1%, the average number of new drug approvals by the FDA over the most recent two-year period, and the contribution of spending on retail and facility-based drugs to total health care spending. Calculations are performed as shown in Table 7.1.

For 2018-19, therefore, the five-year annualized potential budget impact threshold that should trigger policy actions to manage access and affordability is calculated to total approximately \$991 million per year for new drugs.

7.3 Results

Table 7.1 illustrates the per-patient budget impact calculations for lanadelumab in eligible patients with HAE compared to a 49%/49%/2% mix of Haegarda/Cinryze/no long-term prophylaxis. Potential budget impact is presented based on the WAC price of lanadelumab (\$565,557 per year), the net price (\$423,344 per year), and the prices to reach \$150,000, \$100,000, and \$50,000 per QALY in this population (\$374,857, \$372,327, and \$369,798 per year, respectively).

Table 7.1. Per-Patient Budget Impact Calculations Over a Five-Year Time Horizon for Lanadelumab in Eligible Patients with HAE

Average Annual per Patient Budget Impact					
	WAC	Net Price	\$150,000/QALY	\$100,000/QALY	\$50,000/QALY
Lanadelumab	\$620,338	\$478,464	\$430,092	\$427,569	\$425,045
Haegarda/Cinryze/No Long-Term Prophylaxis (49%/49%/2%)	\$524,192				
Difference	\$96,145	-\$45,729*	-\$94,100*	-\$96,624*	-\$99,147*

QALY: quality-adjusted life year

*Cost-saving.

The average potential budgetary impact when using the WAC of lanadelumab was an additional per-patient cost of approximately \$96,100. Lanadelumab at the net price would produce cost savings of approximately \$45,700. In addition, the budget impact would be cost-saving by approximately \$94,100 to \$99,100 as the cost-effectiveness threshold prices for the drug ranged from the annual price of \$374,857 to achieve \$150,000 per QALY to the annual price of \$369,798 to achieve a \$50,000 per QALY cost-effectiveness threshold.

The annual potential budgetary impact of treating the entire eligible population with lanadelumab over five years did not exceed the \$991 million ICER budget impact threshold at any price level, reaching only 13% of the threshold at current WAC (Table 7.2), largely due to the relatively small number of patients eligible for treatment. Furthermore, lanadelumab, compared to a 49%/49%/2% mix of Haegarda/Cinryze/no long-term prophylaxis, was cost-saving in all cases except at WAC, mainly due to the higher costs associated with prophylactic treatment with Cinryze in the comparator arm.

Table 7.2. Estimated Annualized Potential Budget Impact (BI) of Lanadelumab Treatment Using Different Prices Over a Five-Year Time Horizon, Assuming 446 Eligible Patients per Year

	Lanadelumab: Percent of Threshold
WAC	13%
Net Price	-6.2%*
\$150,000 per QALY Threshold Price	-12.7%*
\$100,000 per QALY Threshold Price	-13.0%*
\$50,000 per QALY Threshold Price	-13.4%*

*Cost-saving.

We also conducted a scenario analysis to explore the budget impact when a patient using no long-term prophylaxis switched to lanadelumab. Under this scenario, the average potential budgetary impacts when using the WAC and net price of lanadelumab were additional per-patient costs of approximately \$192,200 and \$50,350, respectively (Table 7.3). The budget impact would be approximately \$1,980 per patient at the price to achieve \$150,000 per QALY, and cost-saving by approximately \$3,100 and \$540 per patient at the prices to achieve \$50,000 and \$100,000 per QALY, respectively.

Table 7.3. Scenario Analysis: Per-Patient Budget Impact Calculations Over a Five-Year Time Horizon for Switch from No Prophylaxis to Lanadelumab in Eligible Patients with HAE

Average Annual per Patient Budget Impact					
	WAC	Net Price	\$150,000/QALY	\$100,000/QALY	\$50,000/QALY
Lanadelumab	\$620,338	\$478,464	\$430,092	\$427,569	\$425,045
No Long-Term Prophylaxis	\$428,111				
Difference	\$192,226	\$50,352	\$1,981	-\$543*	-\$3,066*

QALY: quality-adjusted life year

*Cost-saving.

8. Summary of the Votes and Considerations for Policy

8.1 About the CTAF Process

During CTAF public meetings, the CTAF Panel deliberates and votes on key questions related to the systematic review of the clinical evidence, an economic analysis of the applications of treatments under examination, and the supplementary information presented. Panel members are not preselected based on the topic being addressed and are intentionally selected to represent a range of expertise and diverse perspectives.

Acknowledging that any judgment of evidence is strengthened by real-life clinical and patient perspectives, subject matter experts are recruited for each meeting topic and provide input to CTAF Panel members before the meeting to help clarify their understanding of the different interventions being analyzed in the evidence review. The same clinical experts serve as a resource to the CTAF Panel during their deliberation and help to shape recommendations on ways the evidence can apply to policy and practice.

After the CTAF Panel votes, a policy roundtable discussion is held with the CTAF Panel, clinical experts, patient advocates, payers, and when feasible, manufacturers. The goal of this discussion is to bring stakeholders together to apply the evidence to guide patient education, clinical practice, and coverage, and public policies. Participants on policy roundtables are selected for their expertise on the specific meeting topic, are different for each meeting, and do not vote on any questions.

At the October 25, 2018 meeting, the CTAF Panel discussed issues regarding the application of the available evidence to help patients, clinicians, and payers address important questions related to the use of C1-INH and lanadelumab for long-term prophylaxis for HAE. Following the evidence presentation and public comments (public comments from the meeting can be accessed at <https://www.youtube.com/watch?v=i35Ky1vIOk8>, starting at 01:24:00), the CTAF Panel voted on key questions concerning the comparative clinical effectiveness, comparative value, and other benefits and contextual considerations related to C1-INH and lanadelumab for long-term prophylaxis for HAE. These questions are developed by the ICER research team for each assessment to ensure that the questions are framed to address the issues that are most important in applying the evidence to support clinical practice, medical policy decisions, and patient decision-making. The voting results are presented below, along with specific considerations mentioned by CTAF Panel members during the voting process.

In its deliberations and votes related to value, the CTAF Panel considered the individual patient benefits, and incremental costs to achieve such benefits, from a given intervention over the long

term. There are four elements to consider when deliberating on long-term value for money (see Figure 8.1 below):

1. Comparative clinical effectiveness is a judgment of the overall difference in clinical outcomes between two interventions (or between an intervention and placebo), tempered by the level of certainty possible given the strengths and weaknesses of the body of evidence. CTAF uses the ICER Evidence Rating Matrix as its conceptual framework for considering comparative clinical effectiveness.
2. Estimated incremental cost-effectiveness is the average incremental cost per patient of one intervention compared to another to achieve a desired “health gain,” such as an additional stroke prevented, case of cancer diagnosed, or gain of a year of life. Alternative interventions are compared in terms of cost per unit of effectiveness, and the resulting comparison is presented as a cost-effectiveness ratio. Relative certainty in the cost and outcome estimates continues to be a consideration. As a measure of cost-effectiveness, the CTAF voting panel follows common academic and health technology assessment standards by using cost per quality-adjusted life year (QALY), with formal voting on “long-term value for money” when the base case incremental cost-effectiveness ratio is between \$50,000 per QALY and \$175,000 per QALY. For reviews of ultra-rare conditions, CTAF votes on “long-term value for money” regardless of whether the base-case incremental cost-effectiveness ratio is within the same range.
3. Other benefits refer to any significant benefits or disadvantages offered by the intervention to the individual patient, caregivers, the delivery system, other patients, or the public that would not have been considered as part of the evidence on comparative clinical effectiveness. Examples of other benefits include better access to treatment centers, mechanisms of treatment delivery that require fewer visits to the clinician’s office, treatments that reduce disparities across various patient groups, and new potential mechanisms of action for treating clinical conditions that have demonstrated low rates of response to currently available therapies. Other disadvantages could include increased burden of treatment on patients or their caregivers. For each intervention evaluated, it will be open to discussion whether other benefits or disadvantages such as these are important enough to factor into the overall judgment of long-term value for money. There is no quantitative measure for other benefits or disadvantages.
4. Contextual considerations include ethical, legal, or other issues (but not cost) that influence the relative priority of illnesses and interventions. Examples of contextual considerations include whether there are currently any existing treatments for the condition, whether the condition severely affects quality of life or not, and whether there is significant uncertainty about the magnitude of benefit or risk of an intervention over the long term. There is no quantitative measure for contextual considerations.

Figure 8.1. Conceptual Structure of Long-Term Value for Money

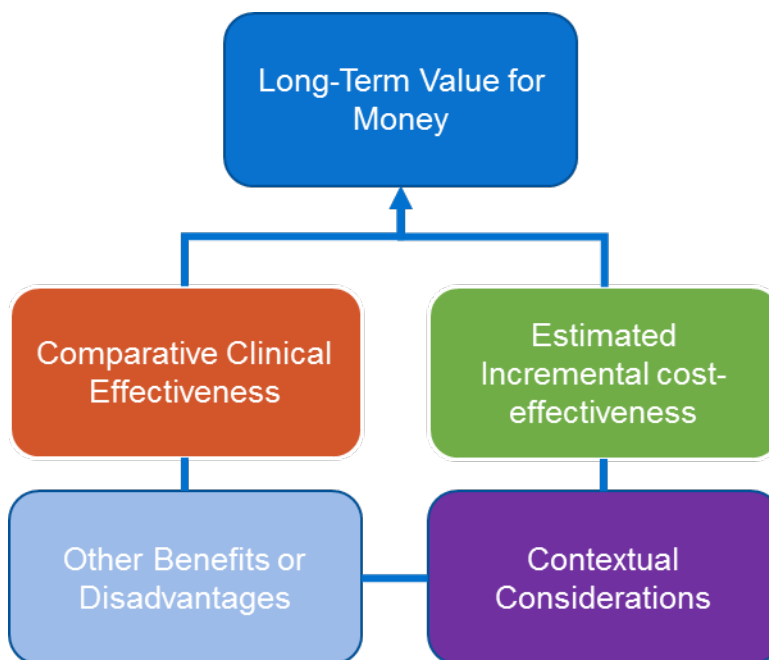

8.2 Voting Results

Patient Population for all questions: Patients with Type 1 and Type 2 Hereditary Angioedema (HAE 1/2) who are eligible for long-term prophylactic therapy.

1. Is the evidence adequate to distinguish the net health benefits between the C1-INHs Cinryze and Haegarda for long-term prophylactic therapy for HAE 1/2?

Yes: 1 vote	No: 14 votes
-------------	--------------

A majority of the Panel voted that the evidence was inadequate to distinguish the net health benefits between Cinryze and Haegarda. Panelists who voted in the negative emphasized that the lack of head-to-head trials precluded their ability to distinguish between the agents. Panelists also cited variation within the clinical trials, including study design, entry criteria, and outcomes measures, which prevented indirect comparisons between the two C1-INHs.

2. Is the evidence adequate to demonstrate that the net health benefits of long-term prophylaxis with C1-INHs for HAE 1/2 are superior to on-demand therapy only?

Yes: 14 votes	No: 1 vote
---------------	------------

A majority of the Panel determined that the evidence was adequate to demonstrate that the net health benefits of long-term prophylaxis with C1-INHs are superior to on-demand therapy only. Although the Panelists who voted in majority judged the evidence to be sufficient, they raised concerns about the lack of long-term data and the small number of patients in the trials. Ultimately, the Panelists noted that these concerns were offset by substantial decreases in attack frequency and severity and the substantial proportion of patients that reached an attack-free state using C1-INHs. The Panelist who voted in the negative cited the lack of long-term data and suggested that some patients with lower baseline attack rates may be better maintained with on-demand therapy only.

3. Is the evidence adequate to demonstrate that the net health benefits of long-term prophylaxis with lanadelumab for HAE 1/2 are superior to on-demand therapy only?

Yes: 4 votes	No: 11 votes
--------------	--------------

A majority of the Panel judged the evidence was inadequate to demonstrate a superior net health benefit of lanadelumab versus on-demand therapy only. The Panelists who voted in the negative cited the lack of data, the small number of patients in the trials, and the unknown long-term risks of inhibiting the kallikrein pathway as the primary justifications for their votes. The four panelists who voted in the affirmative noted that they did so cautiously. These panelists stressed the need for further studies, but stated that they were swayed by the substantial decrease in number of attacks. One panelist who voted in the affirmative also emphasized that the small number of patients in the studies was characteristic of trials for treatments for rare diseases.

4. Does treating HAE 1/2 patients with long-term prophylactic therapy offer one or more of the following potential “other benefits” versus on-demand treatment?

Haegarda offers reduced complexity that will significantly improve patient outcomes.	15/15
Lanadelumab offers reduced complexity that will significantly improve patient outcomes.	13/15
This intervention will reduce important health disparities across racial, ethnic, gender, socioeconomic, or regional categories.	0/15
This intervention will significantly reduce caregiver or broader family burden.	13/15
Lanadelumab offers a novel mechanism of action or approach that will allow successful treatment of many patients for whom other available treatments have failed.	7/15
This intervention will have a significant impact on improving patients'/caregivers' ability to return to work or school and/or their overall productivity.	13/15

This intervention will have a significant positive impact outside the family, including on schools and/or communities.	4/15
This intervention will have a significant impact on the entire “infrastructure” of care, including effects on screening for affected patients, on the sensitization of clinicians, and on the dissemination of understanding about the condition, that may revolutionize how patients are cared for in many ways that extend beyond the treatment itself.	2/15
There are other important benefits or disadvantages that should have an important role in judgments of the value of this intervention.	2/15

A majority of the Panel felt that Haegarda and lanadelumab offer reduced complexity that will significantly improve patient outcomes. These Panelists emphasized that subcutaneous injections are typically easier for patients to administer and may facilitate better adherence than intravenous infusions. Additionally, most Panelists judged that long-term prophylactic therapy will reduce caregiver or family burden by decreasing the anxiety that stems from the unpredictability and recurrent nature of attacks. Similarly, because long-term prophylaxis has been shown to decrease the frequency and severity of attacks, a majority of Panelists also determined that these treatments may positively impact a patient’s ability to return to work or school. Other Panelists noted there may be disadvantages of treatment, including the lack of data on the potential long-term harms of Haegarda and lanadelumab, and the possibility of vein scarring with Cinryze.

5. Are any of the following contextual considerations important in assessing the long-term value for money of long-term prophylactic therapy for HAE 1/2?

This intervention is intended for the care of individuals with a condition of particularly high severity in terms of impact on length of life and/or quality of life.	11/15
This intervention is intended for the care of individuals with a condition that represents a particularly high lifetime burden of illness.	10/15
This intervention is the first to offer any improvement for patients with this condition.	0/15
Compared to on-demand treatment only, there is significant uncertainty about the long-term risk of serious side effects of using C1-INHs .	5/15
Compared to on-demand treatment only, there is significant uncertainty about the long-term risk of serious side effects of using lanadelumab .	14/15
Compared to on-demand treatment only, there is significant uncertainty about the magnitude or durability of the long-term benefits of using C1-INHs .	9/15
Compared to on-demand treatment only, there is significant uncertainty about the magnitude or durability of the long-term benefits of using lanadelumab .	15/15
There are additional contextual considerations that should have an important role in judgments of the value of this intervention.	0/15

A majority of the Panel considered HAE to represent a condition of high severity with a high lifetime burden of illness. However, a majority of Panelists also noted the considerable uncertainty about the long-term risk of serious side effects of both lanadelumab and C1-INHs, due to the lack of long-

term data. These concerns were especially pronounced for lanadelumab, which utilizes a different mechanism of action (kallikrein inhibition). Panelists also voiced concerns about the magnitude and durability of the long-term benefits of especially lanadelumab and Haegarda, which are newer agents with only short studies that included a small number of patients.

6. Given the available evidence on comparative effectiveness and incremental cost-effectiveness, and consider other benefits, disadvantages, and contextual considerations, what is the long-term value for money of long-term prophylaxis of HAE with Cinryze versus on-demand therapy?

Low: 14 votes	Intermediate: 1 vote	High: 0 votes
---------------	----------------------	---------------

A majority of the Panel judged the long-term value for money to be “low” for treatment with Cinryze versus on-demand therapy. Although many Panelists recognized that Cinryze may offer a net health benefit, they were ultimately swayed by the high incremental cost-effectiveness ratios versus on-demand therapy only. The Panelists in the majority also argued that intravenous administration was disadvantageous compared to subcutaneous therapies, which offer reduced complexity and potentially better adherence. Other Panelists voiced concern about the lack of long-term safety data and uncertainty regarding long-term benefit, both of which factored into their ultimate judgment of the value for money to be “low.”

7. Given the available evidence on comparative effectiveness and incremental cost-effectiveness, and considering other benefits, disadvantages, and contextual considerations, what is the long-term value for money of long-term prophylaxis of HAE with Haegarda versus on-demand therapy?

Low: 7 votes	Intermediate: 7 votes	High: 1 vote
--------------	-----------------------	--------------

The Panel was evenly split between “low” and “intermediate” value for money of treatment with Haegarda versus on-demand therapy. The Panelists who determined the value for money to be “low” acknowledged that the treatment offers a large net health benefit, but also emphasized the substantially high cost of treatment. Many Panelists who voted low highlighted the uncertainty surrounding the model, noting that small changes to the model, including baseline attack rate, have a large impact on Haegarda’s cost effectiveness. Many Panelists noted that with a higher baseline attack rate (closer to four attacks per month), the treatment would fall well within commonly-cited cost-effectiveness ranges.

The Panelists who voted “intermediate” emphasized Haegarda’s superior clinical effectiveness, but recognized the high cost of treatment. Some Panelists who voted intermediate also noted similar concerns about the model uncertainty and the lack of long-term safety data. However, these Panelists were persuaded by numerous other benefits, including subcutaneous delivery. Further,

these Panelists stressed that the considerable decrease in attack frequency and severity will have a substantial positive impact on patients and families.

8. Given the available evidence on comparative effectiveness and incremental cost-effectiveness, and considering other benefits, disadvantages, and contextual considerations, what is the long-term value for money of long-term prophylaxis of HAE with lanadelumab versus on-demand therapy?

Low: 13 votes	Intermediate: 2 votes	High: 0 vote
---------------	-----------------------	--------------

A majority of the Panel determined the long-term value for money to be “low” for treatment with lanadelumab versus on-demand therapy. Most Panelists determined the comparative clinical effectiveness of treatment to be “promising but inconclusive” due to the lack of long-term data on safety and harms, especially considering the high rate of post-marketing safety issues associated with monoclonal antibodies. Additionally, the Panel emphasized the high cost of lanadelumab, noting that the treatment exceeds traditional cost-effectiveness thresholds. Although the majority acknowledged some benefits of treatment, including subcutaneous delivery, less frequent dosing, and mechanism of action, they were ultimately persuaded to vote “low” due to the lack of long-term data.

8.3 Roundtable Discussion and Key Policy Implications

Following its deliberation on the evidence, the CTAF Panel engaged in a moderated discussion with a policy roundtable about how best to apply the evidence on C1-INH and lanadelumab for long-term prophylaxis of patients with HAE 1/2 to policy and practice. The policy roundtable members included one patient representative, one clinical expert, a payer, and a representative from a manufacturer. The discussion reflected multiple perspectives and opinions, and therefore, none of the statements below should be taken as a consensus view held by all participants. The names of the Policy Roundtable participants are shown in Table 8.1, and conflict of interest disclosures for all meeting participants can be found in Appendix G.

Table 8.1. Policy Roundtable Members

Policy Roundtable
Debra Bensen-Kennedy, MD Vice President, Medical Affairs CSL Behring
Marco Cicardi, MD Professor of Medicine Università degli Studi di Milano, Italy
April Kunze, PharmD Senior Director, Formulary Development and Trend Management Strategy Prime Therapeutics
Stephanie Smith Patient Advocate

The roundtable discussion was facilitated by Dr. Steven Pearson, MD, MSc, President of ICER. The main themes and recommendations from the discussion are organized by audience and summarized below.

Payers

1. Payers seeking to negotiate better prices may consider giving all market share to subcutaneous treatments.

Two subcutaneous treatments, Haegarda and lanadelumab, are currently available for use as long-term prophylaxis for HAE 1/2. Subcutaneously administered drugs reduce the burden and complexity of administration compared with intravenous drugs, including fewer complications like vein scarring due to repeat intravenous infusions, decreased administration costs, and increased convenience to patients. Patients report that the ability to self-administer therapy may have additional benefits including increased feeling of control over their disease, a greater ability to lead a normal life, and decreased burden on caregivers. For those reasons, it is expected that the vast majority of patients will prefer subcutaneous therapy, and payers could consider coverage policies that favor subcutaneous therapy in order to negotiate deeper discounts for these therapies.

2. Prior authorization criteria should be based on clinical evidence with input from clinical experts and patient groups. Options for specific elements of coverage criteria within insurance coverage policy are discussed below:

Potential Patient Eligibility Criteria

Diagnostic Criteria

a. Patients with HAE 1/2 confirmed by laboratory diagnosis

The diagnosis of HAE 1/2 can be established in multiple ways. Payers could consider requiring lab-confirmed diagnosis of HAE 1/2, which would include measuring C1-INH, C4 protein levels, C1-INH functional levels, and C1q (see Table 8.2).

Table 8.2. Laboratory Diagnosis of HAE 1/2

Laboratory test	Results
Serum C4	Low (< 50% normal)
C1-INH protein	HAE 1: Low (< 50% normal) HAE 2: Normal or high
C1-INH function	Low (< 50% normal)
C1q	Normal

Source: Adapted from Henao et al. Diagnosis and screening of patients with hereditary angioedema in primary care. *Ther Clin Risk Manag.* 2016;12:701-711.¹⁰⁶

b. Physician attestation based on family history or history of response to on-demand treatment

Some payers may wish to write coverage criteria that focus on clinician attestation or on a set of diagnostic criteria that could include a family history of HAE 1/2 that was successfully treated with on-demand therapy, for example, or recurrent angioedema with or without a family history that fails to respond to antihistamines, glucocorticoids, or epinephrine, but does respond to on-demand therapies. Payers should note that since onset of the disease can be in early childhood, confirmatory tests may not be immediately available to the prescribing physician and thus requiring laboratory confirmation may lead to repeat testing. Furthermore, incorrect handling of blood samples can lead to decay of functional C1-INH, which may produce equivocal results on the C1-INH function test. Additionally, patients already on long-term prophylaxis would need to stop treatment and endure a washout period that may be risky in order for the diagnostic testing to be accurate. Thus, patients who are already being successfully treated with long-term prophylaxis for HAE 1/2 should not be required to be retested.

Indication for Long-Term Prophylaxis

a. Attack frequency and severity

Currently, there are no authoritative guidelines for HAE 1/2 that identify disease or attack characteristics that would indicate a need for long-term prophylaxis. Given the high cost of

the current therapies, payers may wish to consider thresholds for starting long-term prophylaxis that may include attack frequency, attack severity, and/or amount of on-demand therapy used.

For attack frequency, a threshold of ≥ 2 attacks per month is in line with the eligibility criteria used in pivotal clinical trials. Based on our cost-effectiveness analyses, thresholds set at 3.8 attacks per month or above could lead to these therapies meeting cost-effectiveness thresholds or, if attack rates are high enough, potentially becoming cost-saving. For example, at a baseline monthly attack rate of 4, both Haegarda and lanadelumab are cost-effective at the \$50,000 willingness-to-pay threshold. Note that the attack rate for cost-effectiveness varies for each drug, and clinical experts may object to thresholds above 2 attacks per month given the lack of justification from consensus guidelines.

The therapies used for long-term prophylaxis all reduced severity of attacks; however, there are no data on a threshold of attack severity for which long-term prophylaxis would be indicated. Nevertheless, guidelines recommend that the impact of attack severity on patient quality of life be incorporated into decision making about whether to begin long-term prophylaxis.

b. Use of on-demand treatment

Frequency or amount of on-demand treatment could be used as proxies for attack severity. Use of on-demand treatment may be a more sensitive indicator of patients who would benefit from long-term prophylaxis, as patients who require a higher level of on-demand therapy likely have more severe disease.

A potential unintended consequence of requiring certain thresholds for coverage of long-term prophylaxis is that patients and doctors may increase treatment above whatever threshold is set in order to qualify for coverage of prophylactic treatment. For example, on-demand therapy is recommended for all moderate to severe attacks, but some mild attacks may not require drug treatment. However, patients who would prefer to be on prophylactic therapy may choose to treat a mild attack with on-demand therapy that they would not otherwise have treated if not attempting to reach a treatment threshold. Similarly, doctors may choose to prescribe or refill on-demand therapy to reach a volume threshold that may trigger eligibility for long-term prophylaxis. Additionally, there may be adverse selection by patients if there is variation in payer thresholds – payers with lower thresholds may see more patients with HAE, particularly in the individual marketplace.

Potential Provider Criteria

a. A requirement for specialty diagnosis for coverage of therapy

Since HAE is an ultra-rare disease, payers may wish to consider requiring diagnosis by an HAE specialist, as that provider would be most likely order the appropriate testing to confirm the diagnosis of HAE 1/2. However, consideration should be given to the fact that in the US, multiple specialties (e.g., allergy-immunology, otolaryngology, pulmonology) may treat patients with HAE, and primary care physicians (including internal medicine, family medicine, and pediatrics) may do the bulk of management for patients with HAE 1/2 after diagnosis is established or in areas where specialists are not readily accessible.

Potential Limitation on Duration or Amount of Medication

a. Coverage caps based on weight-based dosing

Given the high cost of the therapies for HAE 1/2, payers may wish to consider a coverage cap based on weight-based dosing. This is particularly relevant for Haegarda, which uses a weight-based dosing scheme. Although Cinryze dosing is not generally weight-based (a fixed dose of 1,000-2,500 units per dose is recommended), the package labeling lists 100 units/kg as a maximum dosage. Dosing for lanadelumab is also fixed.

3. Given that the cost effectiveness of lanadelumab can be vastly improved by switching attack-free patients from every two week to every four week dosing, payers should work with clinicians to encourage trial periods of the less frequent dosing if patients are attack-free after six months of therapy.

Our economic analysis found that switching approximately 87% of eligible attack-free patients to every four week dosing of lanadelumab resulted in cost-savings over on-demand therapy only. Some percentage of patients will not be able to remain attack-free on the less frequent dosing; however, given the potential cost savings, payers should incentivize clinicians and patients to try less frequent dosing when clinically appropriate.

Manufacturers

4. Innovation that addresses unmet clinical need and produces overall cost savings in the health system is ideal and should be encouraged. However, treatments like Haegarda and lanadelumab can appear cost-saving at a very high price only because of the extremely high annual costs for on-demand treatment of many patients with HAE 1/2. In these situations, reasonable value-based pricing for new treatments requires consideration of a new paradigm for “shared savings” between innovators and society.

Long-term prophylactic therapies for HAE 1/2 cost more than \$30,000 per month, with annual costs around \$400,000, and incremental cost-effectiveness ratios well over the \$150,000 willingness-to-pay threshold that is usually thought of as the upper bound for cost-effective interventions. An estimated 70% of the 6,500 patients in the US with HAE 1/2 reported being treated with long-term prophylaxis, and thus estimated total annual costs for the drugs are near \$2 billion.

Despite these high costs, the ICER economic evaluation found several scenarios where Haegarda and lanadelumab could be cost-saving, particularly in patients with high attack rates or with less-frequent dosing of lanadelumab. However, Haegarda and lanadelumab are considered cost-saving in those scenarios because they reduce the need for on-demand therapy, which itself is very expensive. Still, both Haegarda and lanadelumab are very expensive interventions, with lifetime costs of \$8-10 million per patient.

Is it “fair” for the developers and manufacturers of Haegarda and lanadelumab to realize several billion dollars per year in revenue while potentially saving the health system significant amounts as well? Many would say yes and would highlight the importance of substantial rewards being needed to encourage further innovation of this kind. But what if a one-time cure for HAE 1/2 becomes available for this same group of patients who can have \$10-15 million lifetime health costs? Should the innovator seek a price that captures most of these downstream savings? It seems clear that pricing at that level would prove unaffordable to health systems in the short term, even with an ultra-rare disease like HAE, but a deeper question arises about whether and how the downstream savings should be shared between innovators and society. Given that society has been expending resources for many years to provide extremely high cost therapies to patients who require them, as well as providing funding for research on new therapies, there needs to be consideration of how to reward innovators appropriately while returning considerable savings to the health system and society at large. How this concept of “shared savings” should operate for an ultra-rare disease such as HAE will be an important issue for policy discussions that should occur very soon in the US. ICER intends to convene leaders from the life science and payer communities to begin discussion of this issue in the near future.

5. Manufacturers should ensure that developmental trials consider, whenever possible, adaptive designs that incorporate head-to-head comparison of drugs and standardized, universally recognized quality of life measures to capture a more comprehensive response to treatment. Such information can be then used in to improve patient/provider decision-making and payer evaluation of value.

The current evidence base for treatments for long-term prophylaxis consists of very small placebo-controlled trials with no head-to-head comparisons of treatments, and inconsistent quality of life and patient-reported outcomes. Because for trials for ultra-rare diseases are small, parallel arm trials that include head-to-head comparisons between treatments may not be feasible. However, use of adaptive trial designs that initially includes a placebo component but then moved to compare active therapies could provide better information to guide clinical decision-making and medical policy. Additionally, quality of life and patient-reported outcomes are not consistently included in pivotal trials. Collection of such data, particularly with standardized, universally known measures such as the EQ-5D, would capture more comprehensive understanding of patient response to treatment, as well as facilitate inclusions of these outcomes in the economic modeling.

Providers and Specialty Societies

6. There are currently no consensus criteria on when to consider starting long-term prophylaxis for patients with HAE 1/2. Specialists involved in the care of patients with HAE 1/2 should convene and work with patients to develop a consensus statement to guide policymakers and payers on the appropriate use of long-term prophylaxis for patients with HAE 1/2.

Long-term prophylaxis for HAE 1/2 is a new treatment paradigm, and treatment is with high-cost medications. Thus, guidelines to direct clinicians, patients, and payers on the appropriate indications for long-term prophylaxis are needed. However, because HAE 1/2 is an ultra-rare disease and patients are cared for by a variety of specialties, including allergy/immunology, otolaryngology, pulmonology, internal medicine and pediatrics, no specialty society has taken the lead in developing guidelines for long-term prophylaxis. There is significant disagreement within the provider community on when to switch from on-demand therapy to long-term prophylaxis, and none of the existing clinical trials addresses this question. Number and severity of attacks was suggested as potential criteria, as well as the amount of on-demand therapy being used (e.g., when the amount of on-demand therapy used nears or exceeds the amount used for long-term prophylaxis, it would be reasonable to consider switching to long-term prophylaxis). In the US, most patients are treated by allergists-immunologists, and thus Allergy/Immunology specialty societies such as the American Academy of Allergy, Asthma, and Immunology (AAAAI) should consider leading guideline development.

This is the first ICER review of C1-INHs and lanadelumab for HAE 1/2.

References

1. Zuraw BL. Clinical practice. Hereditary angioedema. *The New England journal of medicine*. 2008;359(10):1027-1036.
2. Germenis AE, Speletas M. Genetics of Hereditary Angioedema Revisited. *Clin Rev Allergy Immunol*. 2016;51(2):170-182.
3. Henry Li H, Riedl M, Kashkin J. Update on the use of C1-esterase inhibitor replacement therapy in the acute and prophylactic treatment of hereditary angioedema. *Clinic Rev Allerg Immunol*. 2018.
4. Lumry WR. Overview of epidemiology, pathophysiology, and disease progression in hereditary angioedema. *Am J Manag Care*. 2013;19(7 Suppl):s103-110.
5. Nzeako UC, Frigas E, Tremaine WJ. Hereditary angioedema: a broad review for clinicians. *Archives of internal medicine*. 2001;161(20):2417-2429.
6. Agostoni A, Cicardi M. Hereditary and acquired C1-inhibitor deficiency: biological and clinical characteristics in 235 patients. *Medicine (Baltimore)*. 1992;71(4):206-215.
7. Bork K, Meng G, Staubach P, Hardt J. Hereditary angioedema: new findings concerning symptoms, affected organs, and course. *Am J Med*. 2006;119(3):267-274.
8. Cicardi M, Zuraw B. Hereditary angioedema: Treatment of acute attacks. *Uptodate*. 2018. <https://www.uptodate.com/contents/hereditary-angioedema-treatment-of-acute-attacks>. Accessed June 28 2018.
9. Banerji A, Li Y, Busse P, et al. Hereditary angioedema from the patient's perspective: A follow-up patient survey. *Allergy Asthma Proc*. 2018;39(3):212-223.
10. Zanichelli A, Mansi M, Azin GM, et al. Efficacy of on-demand treatment in reducing morbidity in patients with hereditary angioedema due to C1 inhibitor deficiency. *Allergy*. 2015;70(12):1553-1558.
11. Lumry WR. Hereditary Angioedema: The Economics of Treatment of an Orphan Disease. *Front Med (Lausanne)*. 2018;5:22.
12. Otani IM, Lumry WR, Hurwitz S, et al. Subcutaneous Icatibant for the Treatment of Hereditary Angioedema Attacks: Comparison of Home Self-Administration with Administration at a Medical Facility. *J Allergy Clin Immunol Pract*. 2017;5(2):442-447 e441.
13. Maurer M, Magerl M, Ansotegui I, et al. The international WAO/EAACI guideline for the management of hereditary angioedema-The 2017 revision and update. *Allergy*. 2018.
14. Longhurst HJ, Farkas H, Craig T, et al. HAE international home therapy consensus document. *Allergy Asthma Clin Immunol*. 2010;6(1):22.
15. Blasco AJ, Lazaro P, Caballero T, Guilarte M. Social costs of icatibant self-administration vs. health professional-administration in the treatment of hereditary angioedema in Spain. *Health Econ Rev*. 2013;3(1):2.
16. Busse P, Bygum A, Edelman J, et al. Safety of C1-esterase inhibitor in acute and prophylactic therapy of hereditary angioedema: findings from the ongoing international Berinert patient registry. *J Allergy Clin Immunol Pract*. 2015;3(2):213-219.
17. Riedl MA, Banerji A, Gower R. Current medical management of hereditary angioedema: follow-up survey of US physicians. *J Allergy Clin Immunol Pract*. 2015;3(2):220-227.
18. Riedl MA, Bygum A, Lumry W, et al. Safety and Usage of C1-Inhibitor in Hereditary Angioedema: Berinert Registry Data. *J Allergy Clin Immunol Pract*. 2016;4(5):963-971.

19. Farkas H, Martinez-Saguer I, Bork K, et al. International consensus on the diagnosis and management of pediatric patients with hereditary angioedema with C1 inhibitor deficiency. *Allergy*. 2017;72(2):300-313.
20. Betschel S, Badiou J, Binkley K, et al. Canadian hereditary angioedema guideline. *Allergy Asthma Clin Immunol*. 2014;10(1):50.
21. Banerji A, Busse P, Christiansen SC, et al. Current state of hereditary angioedema management: a patient survey. *Allergy Asthma Proc*. 2015;36(3):213-217.
22. Caballero T, Aygoren-Pursun E, Bygum A, et al. The humanistic burden of hereditary angioedema: results from the Burden of Illness Study in Europe. *Allergy Asthma Proc*. 2014;35(1):47-53.
23. Bygum A, Aygoren-Pursun E, Beusterien K, et al. Burden of Illness in Hereditary Angioedema: A Conceptual Model. *Acta Derm Venereol*. 2015;95(6):706-710.
24. Lumry WR, Castaldo AJ, Vernon MK, Blaustein MB, Wilson DA, Horn PT. The humanistic burden of hereditary angioedema: Impact on health-related quality of life, productivity, and depression. *Allergy Asthma Proc*. 2010;31(5):407-414.
25. Pharming Group N.V. Pharming Receives Complete Response Letter from FDA. 2018; <https://www.pharming.com/pharming-receives-complete-response-letter-from-fda/>. Accessed October 11, 2018.
26. Zuraw BL, Busse PJ, White M, et al. Nanofiltered C1 inhibitor concentrate for treatment of hereditary angioedema. *New England Journal of Medicine*. 2010;363(6):513-522.
27. Aygören-Pürsün E, Soteres DF, Nieto-Martinez S, et al. Cinryze is efficacious for hereditary angioedema (HAE) attack prevention in pediatric patients: Final phase 3 efficacy and safety results. *Journal of Allergy and Clinical Immunology*. 2018;141(2):AB46.
28. Zuraw BL, Kalfus I. Safety and efficacy of prophylactic nanofiltered C1-inhibitor in hereditary angioedema. *American Journal of Medicine*. 2012;125(9):938.e931-937.
29. Longhurst H, Cicardi M, Craig T, et al. Prevention of Hereditary Angioedema Attacks with a Subcutaneous C1 Inhibitor. Paper presented at: New England journal of medicine 2017.
30. Banerji A, Riedl M, Bernstein J, et al. Lanadelumab for prevention of attacks in hereditary angioedema: Results from the phase 3 help study. *Annals of Allergy, Asthma and Immunology*. 2017;119(5):S5.
31. Downing NS, Shah ND, Aminawung JA, et al. Postmarket Safety Events Among Novel Therapeutics Approved by the US Food and Drug Administration Between 2001 and 2010. *Jama*. 2017;317(18):1854-1863.
32. Nordenfelt P, Dawson S, Wahlgren CF, Lindfors A, Mallbris L, Bjorkander J. Quantifying the burden of disease and perceived health state in patients with hereditary angioedema in Sweden. *Allergy Asthma Proc*. 2014;35(2):185-190.
33. U.S. Census Bureau. Table 1. Projections of the Population and Components of Change for the United States: 2015 to 2060. In. Washington, DC: U.S. Census Bureau; 2014.
34. Bygum A. Hereditary angio-oedema in Denmark: a nationwide survey. *Br J Dermatol*. 2009;161(5):1153-1158.
35. Zanichelli A, Arcoletto F, Barca MP, et al. A nationwide survey of hereditary angioedema due to C1 inhibitor deficiency in Italy. *Orphanet J Rare Dis*. 2015;10:11.
36. Bork K, Barnstedt SE, Koch P, Traupe H. Hereditary angioedema with normal C1-inhibitor activity in women. *Lancet (London, England)*. 2000;356(9225):213-217.
37. Bork K, Wulff K, Witzke G, Hardt J. Treatment for hereditary angioedema with normal C1-INH and specific mutations in the F12 gene (HAE-FXII). *Allergy*. 2017;72(2):320-324.

38. Cicardi M, Bork K, Caballero T, et al. Evidence-based recommendations for the therapeutic management of angioedema owing to hereditary C1 inhibitor deficiency: consensus report of an International Working Group. *Allergy*. 2012;67(2):147-157.
39. Zuraw BL, Banerji A, Bernstein JA, et al. US Hereditary Angioedema Association Medical Advisory Board 2013 recommendations for the management of hereditary angioedema due to C1 inhibitor deficiency. *J Allergy Clin Immunol Pract*. 2013;1(5):458-467.
40. Levy RJ, Lumry WR, McNeil DL, et al. EDEMA4: a phase 3, double-blind study of subcutaneous ecallantide treatment for acute attacks of hereditary angioedema. *Ann Allergy Asthma Immunol*. 2010;104(6):523-529.
41. Zuraw BL, Busse PJ, White M, et al. Nanofiltered C1 inhibitor concentrate for treatment of hereditary angioedema. *The New England journal of medicine*. 2010;363(6):513-522.
42. Farkas H, Martinez-Saguer I, Bork K, et al. International consensus on the diagnosis and management of pediatric patients with hereditary angioedema with C1 inhibitor deficiency. *Allergy*. 2017;72(2):300-313.
43. Levi M, Choi G, Picavet C, Hack CE. Self-administration of C1-inhibitor concentrate in patients with hereditary or acquired angioedema caused by C1-inhibitor deficiency. *J Allergy Clin Immunol*. 2006;117(4):904-908.
44. Boysen HB, Bouillet L, Aygoren-Pursun E. Challenges of C1-inhibitor concentrate self-administration. *Int Arch Allergy Immunol*. 2013;161 Suppl 1:21-25.
45. Poquette C, Starner C, Hall S, P G. Hereditary angioedema drug utilization and spend: a medical and pharmacy integrated analysis. Academy of Managed Care Pharmacy 2015 Annual Meeting & Expo; April 7-10, 2015, 2015; San Diego, California.
46. Tuong LA, Olivieri K, Craig TJ. Barriers to self-administered therapy for hereditary angioedema. *Allergy Asthma Proc*. 2014;35(3):250-254.
47. Cinryze (C1 Esterase Inhibitor [Human]) [package insert]. Shire ViroPharma Incorporated, Lexington, MA. 2016.
48. Haegarda (C1 Esterase Inhibitor Subcutaneous [Human]) [package insert]. CSL Behring GmbH, Marburg, Germany. 2017.
49. Bork K. A Decade of Change: Recent Developments in Pharmacotherapy of Hereditary Angioedema (HAE). *Clin Rev Allergy Immunol*. 2016;51(2):183-192.
50. Woolf S. An organized analytic framework for practice guideline development: using the analytic logic as a guide for reviewing evidence, developing recommendations, and explaining the rationale. *Clinical Practice Guideline Development: Methodology Perspectives AHCPR Pub*. 1994(95-0009):105-113.
51. Shire plc: 3rd Quarter Results [press release]. October 27, 2017 2017.
52. Bjelland I, Dahl AA, Haug TT, Neckelmann D. The validity of the Hospital Anxiety and Depression Scale. An updated literature review. *J Psychosom Res*. 2002;52(2):69-77.
53. UnitedHealthcare. October 2018 Medical Policy Update Bulletin: Medical Policy, Medical Benefit Drug Policy & Coverage Determination Guideline Updates. 2018; <https://www.uhcprovider.com/content/dam/provider/docs/public/resources/news/2018/mpub/medical-policy-update-bulletin-october-2018.pdf>. Accessed 10/10/18, 2018.
54. Medi-Cal DoHCS. Injections: Drugs A-D Policy. 2018:20-21.
55. Aetna. Hereditary Angioedema - Medical Clinical Policy Bulletin. 2018; http://www.aetna.com/cpb/medical/data/700_799/0782.html. Accessed 07/27/2018, 2018.
56. Cigna. Cigna Drug and Biologic Coverage Policy - Hereditary Angioedema (HAE) Therapy. 2017; https://cignaforhcp.cigna.com/public/content/pdf/coveragePolicies/pharmacy/ph_1019_coveragepositioncriteria_hereditary_angioedema.pdf. Accessed 07/27/2018, 2018.
57. HealthNet. Clinical Policy: C1 Esterase Inhibitors (Berinert, Cinryze, Haegarda, Ruconest). 2018.

58. Anthem. Pharmacotherapy for Hereditary Angioedema. 2017; https://www11.anthem.com/ca/medicalpolicies/policies/mp_pw_c164427.htm. Accessed 07/27/2018.
59. UnitedHealthcare. Medical Benefit Drug Policy - Hereditary Angioedema (HAE), Treatment and Prophylaxis. 2017; <https://www.uhcprovider.com/content/dam/provider/docs/public/policies/comm-medical-drug/hereditary-angioedema-treatment-prophylaxis.pdf>. Accessed 07/27/2018, 2018.
60. UnitedHealthcare. 2018 Prescription Drug List - UnitedHealthcare & Affiliated Companies. 2018; <https://www.uhcprovider.com/content/provider/en/viewer.html?file=%2Fcontent%2Fdam%2Fprovider%2Fdocs%2Fpublic%2Fresources%2Fpharmacy%2Fuhc-physician-pdl-list-070118.pdf>. Accessed 07/27/2018, 2018.
61. Aetna. 2018 Aetna Pharmacy Drug Guide - Value Plan. 2018; 667. Available at: https://fm.formularynavigator.com/FBO/41/2018_Aetna_Value_Plan_UM_Doc.pdf. Accessed 07/27/2018, 2018.
62. Anthem. National Drug List - Five Tier Drug Plan. 2018; https://fm.formularynavigator.com/FBO/143/National_5_Tier_ABC.pdf.
63. Cigna. Value 3 Tier Prescription Drug List. 2018; <https://www.cigna.com/individuals-families/member-resources/prescription/drug-list?consumerID=cigna&indicator=nonIFP&pdlYearType=CD&effectiveDate=2018-01-01>. Accessed 07/27/2018.
64. HealthNet. California 3-Tier with Specialty Drug List. 2018. Accessed 07/27/2018, 2018.
65. M M, M M, I A, et al. The international WAO/EAACI guideline for the management of hereditary angioedema—The 2017 revision and update. *Allergy*. 2018;73(8):1575-1596.
66. Cicardi M, Bork K, Caballero T, et al. Evidence-based recommendations for the therapeutic management of angioedema owing to hereditary C1 inhibitor deficiency: consensus report of an International Working Group. *Allergy*. 2012;67(2):147-157.
67. Zuraw BL, Bernstein JA, Lang DM, et al. A focused parameter update: hereditary angioedema, acquired C1 inhibitor deficiency, and angiotensin-converting enzyme inhibitor-associated angioedema. *J Allergy Clin Immunol*. 2013;131(6):1491-1493.
68. Cook DJ, Mulrow CD, Haynes RB. Systematic reviews: synthesis of best evidence for clinical decisions. *Annals of internal medicine*. 1997;126(5):376-380.
69. Higgins JP GS. *Cochrane Collaboration Handbook for Systematic Reviews of Interventions. Version 5.1.0 [updated March 2011]*. The Cochrane Collaboration and John Wiley & Sons Ltd2008.
70. Ollendorf DA, Pearson SD. An integrated evidence rating to frame comparative effectiveness assessments for decision makers. *Medical care*. 2010;48(6 Suppl):S145-152.
71. Agency for Healthcare Research and Quality (AHRQ). US Preventive Services Task Force Procedure Manual. 2008; <https://www.uspreventiveservicestaskforce.org/Home/GetFile/6/7/procmanual/pdf>.
72. Bernstein JA, Manning ME, Li H, et al. Escalating doses of C1 esterase inhibitor (CINRYZE) for prophylaxis in patients with hereditary angioedema. *J Allergy Clin Immunol Pract*. 2014;2(1):77-84.
73. Shire plc. C1 Esterase Inhibitor (C1INH-nf) for the Prevention of Acute Hereditary Angioedema (HAE) Attacks. 2009; <https://clinicaltrials.gov/ct2/show/NCT01005888?term=NCT01005888&rank=1>. Accessed July 23rd, 2018.
74. Shire plc. Efficacy and Safety Study of DX-2930 to Prevent Acute Angioedema Attacks in Patients With Type I and Type II HAE. 2015;

- <https://clinicaltrials.gov/ct2/show/NCT02586805?term=lanadelumab&rank=4>. Accessed July 23rd, 2018.
75. Lumry W, Manning ME, Hurewitz DS, et al. Nanofiltered C1-esterase inhibitor for the acute management and prevention of hereditary angioedema attacks due to C1-inhibitor deficiency in children. *J Pediatr*. 2013;162(5):1017-1022.e1011-1012.
 76. Riedl MA, Tachdjian R, Schranz J, Nurse C, Bernstein JA. Consistent lanadelumab treatment effect in patients with hereditary angioedema (HAE) regardless of baseline attack frequency in the phase 3 HELP study. Paper presented at: Journal of Allergy and Clinical Immunology 2018.
 77. Johnston DT, Anderson JT, Schranz J, Nurse C, Cicardi M. Efficacy of lanadelumab in patients switching from long-term prophylaxis with C1-inhibitor (C1-INH): Results from the phase 3 HELP Study. *Journal of Allergy and Clinical Immunology*. 2018;141(2):AB47.
 78. Lumry WR, Miller DP, Newcomer S, Fitts D, Dayno J. Quality of life in patients with hereditary angioedema receiving therapy for routine prevention of attacks. Paper presented at: Allergy & Asthma Proceedings 2014.
 79. Lumry WR, Craig T, Cicardi M, et al. Can routine prophylactic subcutaneous C1-inhibitor [C1-INH(SC)] alleviate psychological and physical disabilities caused by HAE? Findings from the COMPACT study (NCT01912456). *Allergy, Asthma and Clinical Immunology*. 2017;13.
 80. Weller K, Magerl M, Peveling-Oberhag A, Martus P, Staubach P, Maurer M. The Angioedema Quality of Life Questionnaire (AE-QoL) - assessment of sensitivity to change and minimal clinically important difference. *Allergy*. 2016;71(8):1203-1209.
 81. Lumry WR, Weller K, Magerl M, et al. Lanadelumab markedly improves health-related quality of life in hereditary angioedema patients in the HELP study. Paper presented at: Journal of allergy and clinical immunology 2018.
 82. U S Food and Drug Administration (FDA). Packet Insert - Cinryze. 2008; <https://www.fda.gov/downloads/BiologicsBloodVaccines/BloodBloodProducts/ApprovedProducts/LicensedProductsBLAs/FractionatedPlasmaProducts/UCM129918.pdf>. Accessed July 27, 2018.
 83. Riedl MA, Bygum A, Lumry W, et al. Safety and Usage of C1-Inhibitor in Hereditary Angioedema: Berinert Registry Data. *J Allergy Clin Immunol Pract*. 2016;4(5):963-971.
 84. Fryar C, Gu Q, Ogden C, Flegal K. *Anthropometric reference data for children and adults: United States, 2011–2014*. National Center for Health Statistics. *Vital Health Stat 3(39)*. 2016.
 85. Bork K, Hardt J, Witzke G. Fatal laryngeal attacks and mortality in hereditary angioedema due to C1-INH deficiency. *J Allergy Clin Immunol*. 2012;130(3):692-697.
 86. Federici C, Perego F, Borsoi L, et al. Costs and effects of on-demand treatment of hereditary angioedema in Italy: a prospective cohort study of 167 patients. *BMJ open*. 2018;8(7):e022291.
 87. Zilberberg MD, Nathanson BH, Jacobsen T, Tillotson G. Descriptive epidemiology of hereditary angioedema emergency department visits in the United States, 2006-2007. *Allergy Asthma Proc*. 2011;32(5):390-394.
 88. Personal Health Care (PHC) indices for all services (Table 23). <http://www.cms.gov/Research-Statistics-Data-and-Systems/Statistics-Trends-and-Reports/NationalHealthExpendData/Downloads/Tables.zip>. Accessed June 28 2018.
 89. Price Indexes for Personal Consumption Expenditures. <https://www.bea.gov/iTable/iTable.cfm?reqid=19&step=2#reqid=19&step=3&isuri=1&1921=survey&1903=64>. Accessed June 28 2018.
 90. Consumer Price Index: Medical Care. <https://data.bls.gov/cgi-bin/surveymost>. Accessed June 10 2018.
 91. Lumry W, Bernstein J, Cicardi M, et al. Subcutaneous C1 inhibitor prophylaxis substantially reduces the need for rescue medications in the compact study. Paper presented at: Annals of Allergy, Asthma and Immunology 2017.

92. Ruconest, C1 Esterase Inhibitor (recombinant): Patient Support. <https://www.ruconest.com/patient-support/>. Accessed August 23 2018, 2018.
93. Cinryze (C1 Esterase Inhibitor [Human]): Path to Independence Self-Administration Training. <https://www.cinryze.com/self-administration-training>. Accessed August 23 2018.
94. Graham C, Supina D, Knox H, Krishnarajah S. Cost Savings Associated With Subcutaneous C1-Inhibitor (Human) Long-Term Prophylaxis for Hereditary Angioedema. Paper presented at: Academy of Managed Care Pharmacy October 16-19, 2017; Dallas, Tx, US.
95. Zilberberg MD, Nathanson BH, Jacobsen T, Tillotson G. Descriptive epidemiology of hereditary angioedema hospitalizations in the United States, 2004-2007. *Allergy Asthma Proc*. 2011;32(3):248-254.
96. Li HH, Campion M, Craig TJ, et al. Analysis of hereditary angioedema attacks requiring a second dose of ecallantide. *Ann Allergy Asthma Immunol*. 2013;110(3):168-172.
97. Riedl MA, Levy RJ, Suez D, et al. Efficacy and safety of recombinant C1 inhibitor for the treatment of hereditary angioedema attacks: a North American open-label study. *Ann Allergy Asthma Immunol*. 2013;110(4):295-299.
98. Li HH, Moldovan D, Bernstein JA, et al. Recombinant human-C1 inhibitor is effective and safe for repeat hereditary angioedema attacks. *J Allergy Clin Immunol Pract*. 2015;3(3):417-423.
99. Wilson DA, Bork K, Shea EP, Rentz AM, Blaustein MB, Pullman WE. Economic costs associated with acute attacks and long-term management of hereditary angioedema. *Ann Allergy Asthma Immunol*. 2010;104(4):314-320.
100. United States Food and Drug Administration (FDA). Takhzyro Prescribing Information. 2018; https://www.accessdata.fda.gov/drugsatfda_docs/label/2018/761090s000lbl.pdf.
101. Graham C, Supina D, Knox H, Krishnarajah S. Attacks avoided and cost offsets associated with C1-esterase inhibitor (human) subcutaneous long-term prophylaxis of hereditary angioedema. Paper presented at: 2017 Annual Scientific Meeting of American College of Allergy, Asthma, and Immunology; October 26-30, 2017; Boston, MA, US.
102. Helbert M, Pang F, Alvarez-Reyes M, Pearson I, Wolowacz S, Diwakar L. PSY27 A Cost-Effectiveness Comparison of Icatibant and C1-Esterase Inhibitor Concentrate for the Symptomatic Treatment of Acute Attacks of Types I and II Hereditary Angioedema in the UK Setting. *Value in Health*. 2012;15(7):A513.
103. Kawalec P, Holko P, Paszulewicz A. Cost-utility analysis of Ruconest((R)) (conestat alfa) compared to Berinert((R)) P (human C1 esterase inhibitor) in the treatment of acute, life-threatening angioedema attacks in patients with hereditary angioedema. *Postepy dermatologii i alergologii*. 2013;30(3):152-158.
104. Magliano CA, Tura BR, Santos M, Senna K, Costa MG. COST EFFECTIVENESS OF ICATIBANT FOR HEREDITARY ANGIOEDEMA IN BRAZIL: CHALLENGES IN THE ECONOMIC EVALUATION OF ORPHAN DRUGS. *Value in Health*. 2016;19(3):A248.
105. Pearson SD. The ICER Value Framework: Integrating Cost Effectiveness and Affordability in the Assessment of Health Care Value. *Value in Health*. 2018;21(3):258-265.
106. Henaó MP, Kraschnewski JL, Kelbel T, Craig TJ. Diagnosis and screening of patients with hereditary angioedema in primary care. *Therapeutics and clinical risk management*. 2016;12:701-711.
107. Aygören-Pürsün E, Soteres D, Moldovan D, et al. Preventing Hereditary Angioedema Attacks in Children Using Cinryze(R): interim Efficacy and Safety Phase 3 Findings. *International archives of allergy and immunology*. 2017;173(2):114-119.
108. Longhurst H, Cicardi M, Zuraw B, et al. Subcutaneous C1-INH (SC) preparation (CSL830) in the prevention of Hereditary Angioedema (HAE) attacks: First findings from the COMPACT extension study. *Allergy: European Journal of Allergy and Clinical Immunology*. 2017;72:100-101.

109. Tarzi M, Cicardi M, Zuraw B, et al. Prevention of Hereditary Angioedema (HAE) attacks with subcutaneous C1-INH (SC) preparation of CSL830 in the COMPACT study: Effects on severity and attack location. *Allergy: European Journal of Allergy and Clinical Immunology*. 2017;72:597.
110. Longhurst HJ, Li HH, Riedl MA, et al. Subcutaneous C1-Esterase Inhibitor [C1-INH(SC)] to Prevent Hereditary Angioedema (HAE) Attacks: Subject and investigator assessments from the compact trial. Paper presented at: Journal of Allergy and Clinical Immunology 2017.
111. Craig TJ, Baker JW, Lumry WR, Farkas H, Feuersenger H, Jacobs I. Switch from intravenous C1-Inhibitor C1-INH(IV) to Subcutaneous C1-Inhibitor [C1 INH(SC)] for routine prevention of hereditary angioedema (HAE) attacks: subgroup findings from the compact trial. Paper presented at: Journal of Allergy and Clinical Immunology 2017.
112. Sanders GD, Neumann PJ, Basu A, et al. Recommendations for Conduct, Methodological Practices, and Reporting of Cost-effectiveness Analyses: Second Panel on Cost-Effectiveness in Health and Medicine. *Jama*. 2016;316(10):1093-1103.

APPENDICES

Appendix A. Search Strategies and Results

Table A1. PRISMA 2009 Checklist

	#	Checklist item
TITLE		
Title	1	Identify the report as a systematic review, meta-analysis, or both.
ABSTRACT		
Structured Summary	2	Provide a structured summary including, as applicable: background; objectives; data sources; study eligibility criteria, participants, and interventions; study appraisal and synthesis methods; results; limitations; conclusions and implications of key findings; systematic review registration number.
INTRODUCTION		
Rationale	3	Describe the rationale for the review in the context of what is already known.
Objectives	4	Provide an explicit statement of questions being addressed with reference to participants, interventions, comparisons, outcomes, and study design (PICOS).
METHODS		
Protocol and Registration	5	Indicate if a review protocol exists, if and where it can be accessed (e.g., Web address), and, if available, provide registration information including registration number.
Eligibility Criteria	6	Specify study characteristics (e.g., PICOS, length of follow-up) and report characteristics (e.g., years considered, language, publication status) used as criteria for eligibility, giving rationale.
Information Sources	7	Describe all information sources (e.g., databases with dates of coverage, contact with study authors to identify additional studies) in the search and date last searched.
Search	8	Present full electronic search strategy for at least one database, including any limits used, such that it could be repeated.
Study Selection	9	State the process for selecting studies (i.e., screening, eligibility, included in systematic review, and, if applicable, included in the meta-analysis).
Data Collection Process	10	Describe method of data extraction from reports (e.g., piloted forms, independently, in duplicate) and any processes for obtaining and confirming data from investigators.
Data Items	11	List and define all variables for which data were sought (e.g., PICOS, funding sources) and any assumptions and simplifications made.
Risk of Bias in Individual Studies	12	Describe methods used for assessing risk of bias of individual studies (including specification of whether this was done at the study or outcome level), and how this information is to be used in any data synthesis.
Summary Measures	13	State the principal summary measures (e.g., risk ratio, difference in means).
Synthesis of Results	14	Describe the methods of handling data and combining results of studies, if done, including measures of consistency (e.g., I^2) for each meta-analysis.

Risk of Bias Across Studies	15	Specify any assessment of risk of bias that may affect the cumulative evidence (e.g., publication bias, selective reporting within studies).
Additional Analyses	16	Describe methods of additional analyses (e.g., sensitivity or subgroup analyses, meta-regression), if done, indicating which were pre-specified.
RESULTS		
Study Selection	17	Give numbers of studies screened, assessed for eligibility, and included in the review, with reasons for exclusions at each stage, ideally with a flow diagram.
Study Characteristics	18	For each study, present characteristics for which data were extracted (e.g., study size, PICOS, follow-up period) and provide the citations.
Risk of Bias within Studies	19	Present data on risk of bias of each study and, if available, any outcome level assessment (see item 12).
Results of Individual Studies	20	For all outcomes considered (benefits or harms), present, for each study: (a) simple summary data for each intervention group (b) effect estimates and confidence intervals, ideally with a forest plot.
Synthesis of Results	21	Present results of each meta-analysis done, including confidence intervals and measures of consistency.
Risk of Bias Across Studies	22	Present results of any assessment of risk of bias across studies (see Item 15).
Additional Analysis	23	Give results of additional analyses, if done (e.g., sensitivity or subgroup analyses, meta-regression [see Item 16]).
DISCUSSION		
Summary of Evidence	24	Summarize the main findings including the strength of evidence for each main outcome; consider their relevance to key groups (e.g., health care providers, users, and policy makers).
Limitations	25	Discuss limitations at study and outcome level (e.g., risk of bias), and at review-level (e.g., incomplete retrieval of identified research, reporting bias).
Conclusions	26	Provide a general interpretation of the results in the context of other evidence, and implications for future research.
FUNDING		
Funding	27	Describe sources of funding for the systematic review and other support (e.g., supply of data); role of funders for the systematic review.

From: Moher D, Liberati A, Tetzlaff J, Altman DG. The PRISMA Group (2009). Preferred Reporting Items for Systematic Reviews and Meta-Analyses: The PRISMA Statement. PLoS Med 6(6): e1000097. doi:10.1371/journal.pmed1000097.

Table A2. Search Strategy of Medline 1996 to Present with Daily Update and Cochrane Central Register of Controlled Trials on New Drugs

No.	Search Terms
1	exp Angioedemas, Hereditary/
2	(hereditary angioedema or HAE).ti,ab.
3	1 or 2
4	exp Complement C1 Inhibitor Protein/
5	('C1 Esterase Inhibitor' or C1 inhibitor protein or 'C1-INH Protein' or 'C1 INH protein').ti,ab.
6	Cinryze.ti,ab.
7	(Haegarda or CSL830).ti,ab.
8	(ruconest or 'recombinant human C1 inhibitor' or 'rhC1INH').ti,ab.
9	(lanadelumab or SHP643 or DX-2930 or 'DX 2930').ti,ab.
10	4 or 5 or 6 or 7 or 8 or 9
11	3 and 10
12	(abstract or addresses or autobiography or bibliography or biography or clinical trial, phase i or case report or comment or congresses or consensus development conference or duplicate publication or editorial or guideline or in vitro or interview or lecture or legal cases or legislation or letter or news or newspaper article or patient education handout or periodical index or personal narratives or portraits or practice guideline or review or video-audio media).pt
13	cohort studies/ or longitudinal studies/ or prospective studies/ or retrospective studies/ or comparative study.pt.
14	control groups/ or (control* adj2 (clinical or group* or trial* or study or studies or design* or arm*)).ti,ab. or ("clinical trial" or "clinical trial, phase ii" or clinical trial, phase iii or clinical trial, phase iv or controlled clinical trial or "multicenter study" or "randomized controlled trial").pt. or (random?ed adj6 (study or trial* or (clinical adj2 trial*))).ti,ab.
15	13 or 14
16	11 not 12
17	15 and 16
18	animals not (humans and animals)).sh.
19	17 not 18
20	limit 19 to english language
21	remove duplicates from 20
Most recent search: September 24, 2018	

*Ruconest is now excluded from the scope of the review.

Table A3. Search Strategy in EMBASE

No.	Search Terms
#1	'hereditary angioedema'/exp OR 'hereditary angioedema' OR (hereditary AND ('angioedema'/exp OR angioedema))
#2	'complement component c1s inhibitor'/exp
#3	'c1 esterase inhibitor' OR 'c1 inhibitor protein' OR 'c1 inh' OR 'c1-inh'
#4	'cinryze'
#5	'haegarda' OR 'csl830'
#6	'ruconest' OR 'recombinant human c1 inhibitor' OR 'rhc1inh'
#7	'lanadelumab' OR 'shp643' OR 'dx-2930'
#8	#2 OR #3 OR #4 OR #5 OR #6 OR #7
#9	#1 AND #8
#10	'animal'/exp OR 'nonhuman'/exp OR 'animal experiment'/exp
#11	'human'/exp
#12	#10 AND #11
#13	#10 NOT #12
#14	#9 NOT #13
#15	#14 AND [english]/lim
#16	#15 AND [medline]/lim
#17	#15 NOT #16
#18	#17 AND ('chapter'/it OR 'editorial'/it OR 'letter'/it OR 'note'/it OR 'review'/it OR 'short survey'/it)
#19	#17 NOT #18
Most recent search: September 24, 2018	

*Ruconest is now excluded from the scope of the review.

Figure A1. PRISMA Flow Chart Showing Results of Literature Search for Hereditary Angioedema

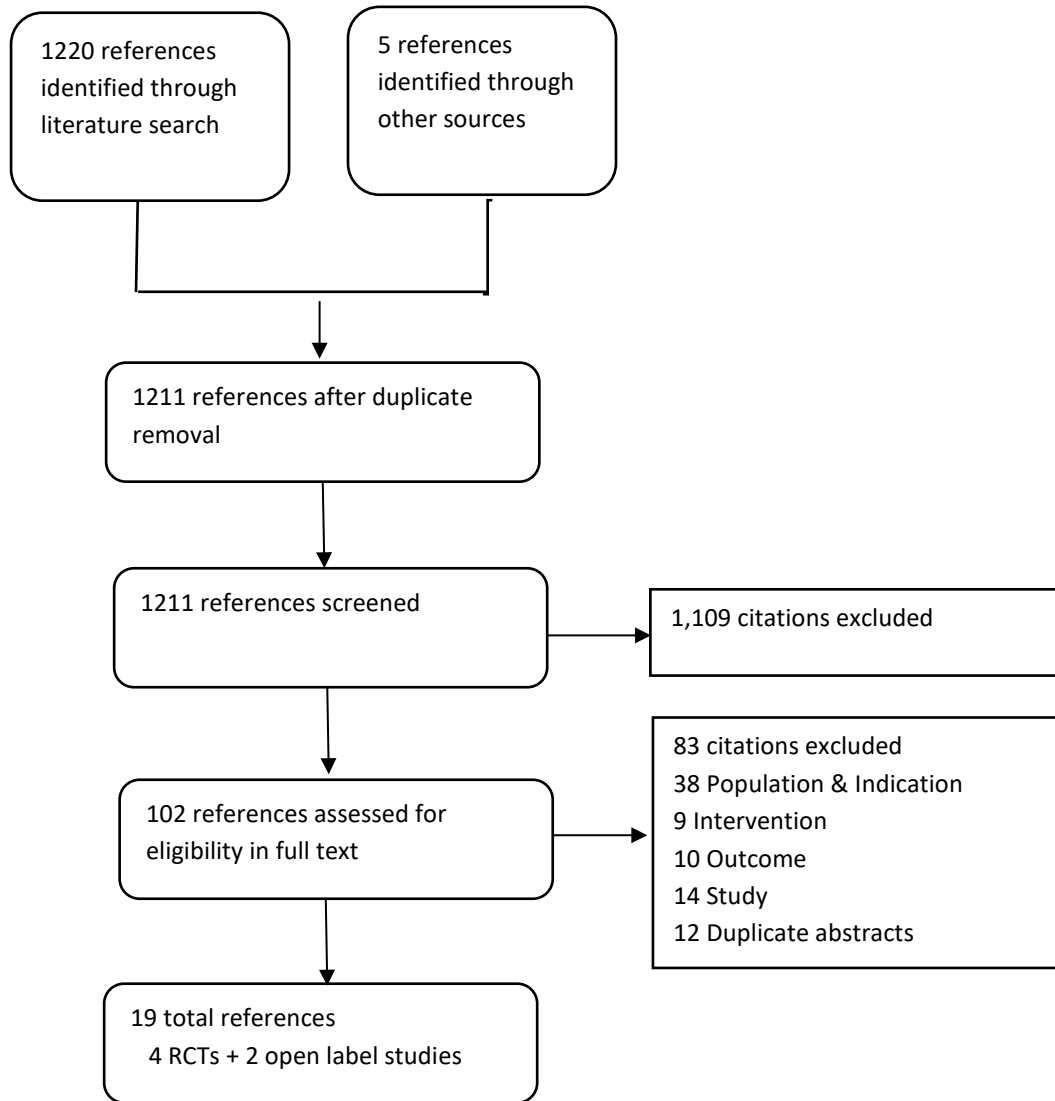

Appendix B. Previous Systematic Reviews and Technology Assessments

We identified one health technology appraisal conducted by the Canadian Agency for Drugs and Technologies in Health (CADTH) on C1-INHs for both long-term and short-term prophylaxis in patients with HAE. The technology assessment is summarized below. In addition, the National Institute for Health and Care Excellence (NICE) is currently reviewing lanadelumab for long-term prophylaxis in HAE Types 1 and 2 and the citation for the ongoing assessment is provided below.

CADTH: C1 Esterase Inhibitor for Prophylaxis against Hereditary Angioedema Attacks: A Review of the Clinical Effectiveness, Cost-Effectiveness, and Guidelines

<https://www.cadth.ca/c1-esterase-inhibitor-prophylaxis-against-hereditary-angioedema-attacks-review-clinical>

CADTH sought to assess available evidence on the clinical effectiveness, cost effectiveness and evidence-based guidelines of C1-INHs for short-term and long-term prophylaxis in patients with hereditary angioedema. The authors identified one systematic review, one randomized placebo-controlled trial, nine non-randomized studies as well as one evidenced based guideline for their review. C1-INHs were shown to be relatively safe, and effective in reducing the severity and frequency of HAE attacks when used as either short-term prophylaxis or long-term prophylaxis. However, the authors noted that the identified trials were marked by several limitations such as small sample size due to the rare nature of the disease, lack of comparator groups, and uncertain blinding. No cost effectiveness studies were identified for the review.

NICE: Lanadelumab for the Long-Term Prevention Of Angioedema Attacks In Hereditary Angioedema Types I And II

<https://www.nice.org.uk/guidance/proposed/gid-ta10333/documents>

NICE is currently appraising the clinical effectiveness and cost effectiveness of lanadelumab for the long-term prevention of attacks in patients with HAE Types 1 and 2.

Appendix C. Ongoing Studies

Table C1. Ongoing Studies

Title/ Trial Sponsor	Study Design	Comparators	Patient Population	Primary Outcomes	Estimated Completion Date
Lanadelumab					
A Phase 3, Open-Label Study of HELP study to Evaluate the long-term Safety and Efficacy of Lanadelumab for Prevention Against Acute Attacks of HAE Sponsored by Shire NCT02741596	Phase III Open label Non-randomized Single group assignment Estimated enrollment: 220	1. Experimental: Rollover participants Participants rollover from DX-2930-03 study receive 300 mg Lanadelumab at Day 0 followed by second dose following the first HAE attack and then once in every 2 weeks to the end (up to 924 days) Wash-out period: 10 to 18 days 2. Experimental: Non-rollover participants Participants who were not part of DX-2930-03 study receive 300 mg Lanadelumab once in every 2 weeks to the end	<u>Inclusion Criteria</u> ≥12 years with confirmed diagnosis of HAE type I or II, a low functional C1-INH level <40% of the normal level, and a historical baseline HAE attack rate of ≥1 attack per 12 weeks <u>Exclusion Criteria</u> If patients discontinued from DX-2930-03 (NCT02586805) after enrollment for any reason; If rolling over from DX-2930-03, presence of important safety concerns that would preclude participation in this study; Pregnancy or breastfeeding; Use of any other investigational drug	Primary Outcome Measures <u>Long-term Safety:</u> based on treatment-emergent AEs, from Day 0 up to Day 956 Secondary Outcome Measures <u>Long-term Safety:</u> based on the number of investigator-confirmed HAE attacks requiring acute treatment, number of moderate or severe investigator-confirmed HAE attacks and the number of high-morbidity investigator-confirmed HAE attacks during the treatment period <u>Dosing frequency of Lanadelumab:</u> assess the duration of time between a rollover participant's first and second open-label dose, from Day 0 up to Day 956	November 2019

Source: www.ClinicalTrials.gov (NOTE: studies listed on site include both clinical trials and observational studies)

Appendix D. Comparative Clinical Effectiveness

Supplemental Information

We performed screening at both the abstract and full-text level. Two investigators screened all abstracts identified through electronic searches according to the inclusion and exclusion criteria described earlier. We did not exclude any study at abstract-level screening due to insufficient information. For example, an abstract that did not report an outcome of interest would be accepted for further review in full text. We retrieved the citations that were accepted during abstract-level screening for full text appraisal. One investigator reviewed full papers and provided justification for exclusion of each excluded study.

We also included FDA documents (for example, FDA prescribing information, manufacturer's submission to the agency).

We used criteria published by the US Preventive Services Task Force (USPSTF) to assess the quality of RCTs and comparative cohort studies, using the categories "good," "fair," or "poor" (see Appendix Table F2)⁷¹ Guidance for quality ratings using these criteria is presented below, as is a description of any modifications we made to these ratings specific to the purposes of this review.

Good: *Meets all criteria: Comparable groups are assembled initially and maintained throughout the study; reliable and valid measurement instruments are used and applied equally to the groups; interventions are spelled out clearly; all important outcomes are considered; and appropriate attention is paid to confounders in analysis. In addition, intention to treat analysis is used for RCTs.*

Fair: *Studies were graded "fair" if any or all of the following problems occur, without the fatal flaws noted in the "poor" category below: Generally comparable groups are assembled initially but some question remains whether some (although not major) differences occurred with follow-up; measurement instruments are acceptable (although not the best) and generally applied equally; some but not all important outcomes are considered; and some but not all potential confounders are addressed. Intention to treat analysis is done for RCTs.*

Poor: *Studies were graded "poor" if any of the following fatal flaws exists: Groups assembled initially are not close to being comparable or maintained throughout the study; unreliable or invalid measurement instruments are used or not applied equally among groups (including not masking outcome assessment); and key confounders are given little or no attention. For RCTs, intention to treat analysis is lacking.*

Note that case series are not considered under this rating system – because of the lack of comparator, these are generally considered to be of poor quality.

ICER Evidence Rating

We used the [ICER Evidence Rating Matrix](#) (see Figure D1) to evaluate the evidence for a variety of outcomes. The evidence rating reflects a joint judgment of two critical components:

- The **magnitude** of the difference between a therapeutic agent and its comparator in “net health benefit” – the balance between clinical benefits and risks and/or adverse effects AND
- The level of **certainty** in the best point estimate of net health benefit.⁷⁰

Figure D1. ICER Evidence Rating Matrix

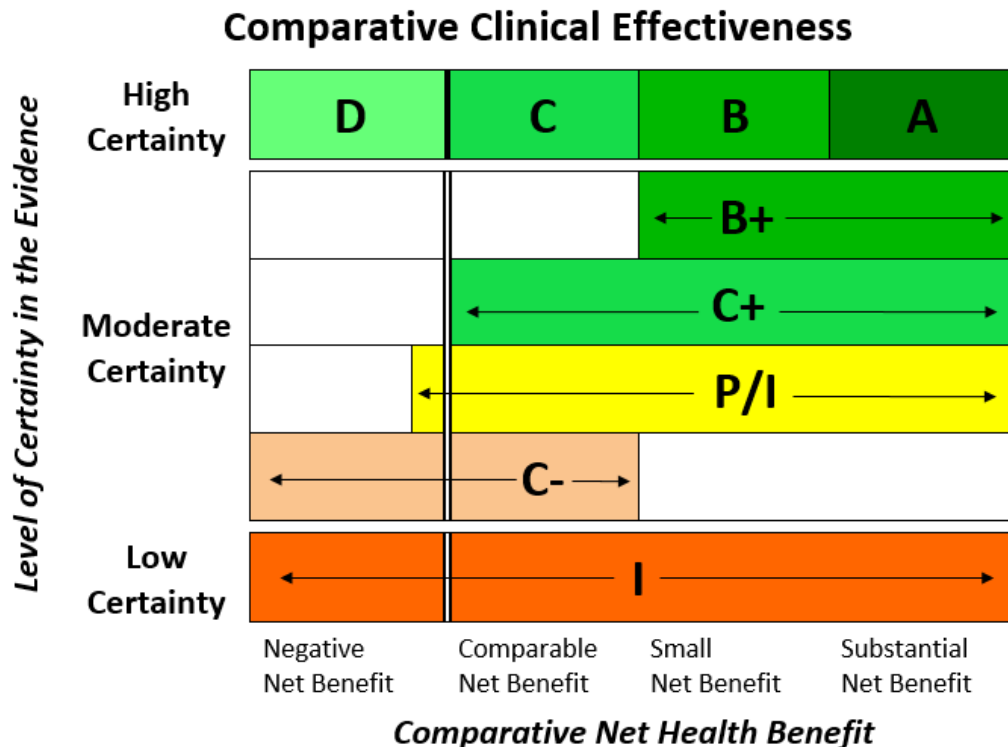

A = “Superior” - High certainty of a substantial (moderate-large) net health benefit

B = “Incremental” - High certainty of a small net health benefit

C = “Comparable” - High certainty of a comparable net health benefit

D = “Negative” - High certainty of an inferior net health benefit

B+ = “Incremental or Better” - Moderate certainty of a small or substantial net health benefit, with high certainty of at least a small net health benefit

C+ = “Comparable or Better” - Moderate certainty of a comparable, small, or substantial net health benefit, with high certainty of at least a comparable net health benefit

P/I = “Promising but Inconclusive” - Moderate certainty of a comparable, small, or substantial net health benefit, and a small (but nonzero) likelihood of a negative net health benefit

C- = “Comparable or Inferior” - Moderate certainty that the point estimate for comparative net health benefit is either comparable or inferior

I = “Insufficient” - Any situation in which the level of certainty in the evidence is low

Table D1. Evidence Tables

Author & Year of Publication (Trial Name) Quality Rating	Study Design and Duration of Follow-Up	Interventions (n) & Dosing Schedule	Inclusion and Exclusion Criteria	Patient Characteristics	Outcomes	Harms
Cinryze						
<p>Zuraw NEJM 2010²⁶ NCT01005888</p> <p>Fair</p>	<p>Phase III, randomized, double-blind, placebo-controlled crossover study</p> <p>24 weeks (two consecutive 12-week treatment periods)</p>	<p>1) Placebo crossover to Cinryze, n=11</p> <p>2) Cinryze crossover to placebo, n=11</p> <p>Patients received prophylactic injection every 3 to 4 days. Subjects were randomized to either 1000 units of Cinryze or placebo during the first period. For the second period, patients received the study medication that has not been assigned during the first period.</p>	<p>Inclusions:</p> <p>≥6 years with confirmed diagnosis of HAE and a low anti-genetic or functional C1-INH level or a mutation in C1 gene causing HAE plus history of ≥2 attacks/month</p> <p>Exclusion</p> <p>Low C1q level; history of B-cell cancer, allergic reaction to C1 or other blood products; presence of anti-C1-INH antibody; pregnancy and narcotic addiction</p>	<p>Mean age (SD)</p> <p>1) 34.5 (14.8)</p> <p>2) 41.7 (19.3)</p> <p>Female, n (%)</p> <p>1) 11 (100)</p> <p>2) 9 (81.8)</p> <p>Years since diagnosis (SD)</p> <p>1) 16.8 (7.9)</p> <p>2) 19.3 (14.4)</p> <p>Type II HAE, n (%)</p> <p>1) 2 (18.2)</p> <p>2) 2 (18.2)</p> <p>White, n (%)</p> <p>1) 11 (100)</p> <p>2) 9 (90.9)</p> <p>Androgen therapy at baseline, n (%)</p> <p>1) 1 (9.1)</p> <p>2) 2 (18.2)</p>	<p>Total N= 22</p> <p>Average normalized attack rates over 12 weeks</p> <p>Cinryze prophylaxis: 6.26</p> <p>Placebo: 12.73</p> <p>Mean difference 6.47; p<0.001</p> <p>Mean severity score (SD)</p> <p>Cinryze prophylaxis: 1.3 (0.85)</p> <p>Placebo: 1.9 (0.36)</p> <p>P<0.001</p> <p>Duration of attack, days (SD)</p> <p>Cinryze prophylaxis: 2.1 (1.13)</p> <p>Placebo: 3.4 (1.39)</p> <p>P=0.002</p> <p>Patients that received open-label rescue therapy, n</p> <p>Cinryze Prophylaxis: 11 patients</p> <p>Placebo: 22</p>	<p>Any type of AE, n (%)</p> <p>21 (87.5)</p>

Author & Year of Publication (Trial Name) Quality Rating	Study Design and Duration of Follow-Up	Interventions (n) & Dosing Schedule	Inclusion and Exclusion Criteria	Patient Characteristics	Outcomes	Harms
<p>Lumry Allergy Asthma 2017²⁸</p> <p>NCT01005888</p> <p>Main trial: Zuraw NEJM 2010⁴¹</p>	<p>Phase III, randomized, multicenter, double-blind, placebo-controlled crossover study (quality of life outcome)</p> <p>24 weeks (two consecutive 12-week treatment periods)</p>	See Zuraw 2010	See Zuraw 2010	<p>Mean age, years (SD) 41.69 (14.95)</p> <p>Female, n (%) 14 (87.5)</p> <p>Mean attacks/month on placebo (SD) 4.20 (1.40)</p> <p>Mean attacks/month on C1 INH-nf (SD) 2.24 (1.96)</p> <p>Mean physical summary scores (SD) 36.41 (10.23)</p> <p>Mean mental component scores (SD) 49.90 (9.96)</p>	<p>16 patients had evaluable SF-36 data</p> <p>Mean physical summary scores (SD) <u>Received C1 INH-nf for 12 weeks</u> 43.92 (12.84) <u>After received placebo</u> 37.06 (11.60)</p> <p>Mean mental component scores (SD) <u>Received C1 INH-nf for 12 weeks</u> 54.00 (7.82) <u>After received placebo</u> 44.98 (16.07)</p>	Zuraw 2010
<p>Zuraw Am J Med 2012²⁸</p> <p>NCT01005888</p> <p>Fair</p>	<p>Open-label, single-arm, multicenter, extension study</p> <p>The study provided the results of prophylactic C1INH-nf treatment in 146 patients with HAE treated for up to 2.6 years</p>	Patients received 1000 units of Cinryze every 3 to 7 days (n=146)	<p>Inclusions: ≥1 years with confirmed diagnosis of HAE plus history of ≥1 attacks/month or any laryngeal angioedema</p> <p>Exclusion History of, allergic reaction to C1INH or other blood products; participation in another clinical trial within 30 days of enrollment or received blood</p>	<p>Mean age (SD) 36.5 (16.5)</p> <p>Female, n (%) 112 (76.7)</p> <p>Mean attack rate (SD) 4.7 (5.2)</p>	<p>Frequency of attack, n (%) No attacks: 51 (34.6) ≤1 attack/month: 128 (87.7) >1 attack/month: 18 (12.3)</p> <p>Frequency of prophylaxis use 2ce/week: 7 patients Once/week: 23 patients 2ce/week plus once/week: 116 patients Average use: 1.4 injection/ week</p>	<p>Number of SAE: 101 (99 were considered not to be related)</p> <p>Thrombotic events, n 5 patients</p> <p>Severe hypersensitivity None</p> <p>Anti-C1INH antibody None</p> <p>Death 2 patients (considered to be unrelated)</p>

Author & Year of Publication (Trial Name) Quality Rating	Study Design and Duration of Follow-Up	Interventions (n) & Dosing Schedule	Inclusion and Exclusion Criteria	Patient Characteristics	Outcomes	Harms
			products within 60 days of enrollment			
<p>Lumry Pediatrics 2013⁷⁵</p> <p>NCT01005888</p> <p>Main trials: Zuraw NEJM 2010⁴¹ Zuraw Am J Med 2012²⁸</p>	<p>Phase III, randomized, double-blind, placebo-controlled crossover study</p> <p>AND</p> <p>Open-label, single-arm, multicenter, extension study</p> <p>(Pediatric subgroup analysis)</p>	<p><u>For the placebo-controlled trial</u></p> <p>Patients received prophylactic injection every 3 to 4 days. Subjects were randomized to either 1000 units of Cinryze or placebo during the first period. For the second period, patients received the study medication that has not been assigned during the first period.</p> <p><u>Open-label trial</u></p> <p>Patients received 1000 units of Cinryze every 3 to 7 days</p>	<p>See Zuraw NEJM 2010 & Zuraw Am J Med 2012</p> <p>Children (aged <18 years) who participated in these studies, were included in the subgroup analysis</p>	<p>See Zuraw NEJM 2010 & Zuraw Am J Med 2012</p> <p><u>Open-label data (N=23)</u></p> <p>Median baseline monthly attack rate (range): 3.0 (0.5-28.0)</p>	<p><u>Placebo-controlled data (N=4)</u></p> <p>The mean number of attacks over 12 weeks</p> <p>Cinryze prophylaxis: 7.0 Placebo: 13.0</p> <p>The mean severity scores</p> <p>Cinryze prophylaxis: 1.6</p> <p>The mean duration of attacks over 12 weeks, days</p> <p>Cinryze prophylaxis: 2.3 Placebo: 2.6</p> <p><u>Open-label data (N=23)</u></p> <p>The median monthly attack rate [range]</p> <p>Cinryze prophylaxis: 0.39 [0-3.36]</p> <p>Mean attacks per month per patient received Cinryze prophylaxis (SD)</p> <p><u>2-5 years group, n=2</u> 0.69 (0.977)</p> <p><u>6-11 years group, n=9</u> 0.35 (0.453)</p> <p><u>12-17 years group, n=12</u> 0.71 (0.897)</p> <p>Frequency of attack, n (%)</p> <p>≤1 attack per month: 20 (87) No attack: 5 (22)</p>	<p>For patients received prophylaxis treatment: No serious AEs reported</p> <p>Pyrexia n=1</p> <p><u>Open-label extension period</u></p> <p>All treatment-related AEs: n=17 (74%)</p> <p>Headache: n=1</p> <p>Nausea: n=1</p> <p>Infusion-site erythema: n=1</p>
<p>Aygören-Pürsün Arch Allergy Immunol 2017¹⁰⁷</p>	<p>Ongoing Phase III, randomized, single-blind crossover study</p>	<p>1) 500 Cinryze crossover to 1000 Cinryze, n=2</p>	<p>Inclusions:</p> <p>≥6 years and <12 years with confirmed diagnosis of HAE, a functional C1-INH</p>	<p>Median age, years [range]</p> <p>10.5 [7.0-11.0]</p> <p>Female, n (%)</p> <p>6 (100)</p>	<p>The mean number of normalized attacks per month, n (SD)</p> <p>After 12 weeks observation: 2.26 (1.62) 500 Cinryze: 0.37 (0.47) Mean difference from baseline: -1.89</p>	<p>No serious adverse events or discontinuation occurred</p> <p>Any type of AEs:</p>

Author & Year of Publication (Trial Name) Quality Rating	Study Design and Duration of Follow-Up	Interventions (n) & Dosing Schedule	Inclusion and Exclusion Criteria	Patient Characteristics	Outcomes	Harms
<p>NCT02052141</p> <p>Fair</p> <p>See Aygören-Pürsün <i>Allergy Clin Immun</i> 2018²⁷ for the completed trial</p>	<p>24 weeks (two consecutive 12-week treatment periods after a 12-week qualifying observation period)</p>	<p>2) 1000 Cinryze crossover to 500 Cinryze, n=4</p> <p>Total N = 6</p> <p>Patients received prophylactic injection every 3 to 4 days. Subjects were randomized to either 500 units or 1000 units of Cinryze during the first period. For the second period, patients switched to the alternative dose for another 12 weeks.</p>	<p>level <50% of normal levels, and a monthly average of ≥1 attacks classified as moderate to severe before screening</p> <p>Exclusion With a history of hypercoagulability, allergic reaction to C1-INH products, or an acquired angioedema diagnosis</p>	<p>White, n (%) 5 (83.3)</p> <p>HAE type I, n (%) 6 (100)</p> <p>Median weight, kg [range] 32.0 [23.2-47.1]</p> <p>Attacks that occurred up to 3 months before screening <i>Median number of attacks [range]</i> 4 [3-6] <i>Average duration of attacks, days [range]</i> 1.5 [1-3] <i>Patients needed acute treatment for HAE attack, n (%)</i> 2 (33.3)</p>	<p>1000 Cinryze: 0.37 (0.57) <i>Mean difference from baseline: -1.89</i></p> <p>Cumulative attack severity (SD) After 12 weeks observation: 4.09 (2.24) 500 Cinryze = 0.62 (0.91) <i>Mean difference from baseline: -3.47</i> 1000 Cinryze = 0.50 (0.73) <i>Mean difference from baseline: -3.60</i></p> <p>Cumulative daily attack severity (SD) After 12 weeks observation: 7.51 (4.76) 500 Cinryze = 2.00 (4.03) <i>Mean difference from baseline: -5.51</i> 1000 Cinryze = 0.93 (1.19) <i>Mean difference from baseline: -6.58</i></p> <p>The number of attacks requiring acute treatment, n (SD) After 12 weeks observation: 0.7 (0.78) 500 Cinryze = 0.06 (0.15) <i>Mean difference from baseline: -0.64</i> 1000 Cinryze = 0.00 (0.00) <i>Mean difference from baseline: -0.70</i></p>	<p>Total N = 5</p> <p>Fatigue, n (%) 500 Cinryze = 1 (16.7) 1000 Cinryze = 1 (16.7)</p> <p>Irritability, n (%) 500 Cinryze = 1 (16.7) 1000 Cinryze = 1 (16.7)</p>
<p>Aygören-Pürsün <i>Allergy Clin Immun</i> 2018²⁷</p> <p>Conference abstract</p> <p>NCT02052141</p> <p>See Aygören-Pürsün 2017</p>	<p>Phase III, randomized, single-blind crossover study (completed)</p> <p>24 weeks (two consecutive 12-week treatment periods after a 12-week qualifying observation period)</p>	<p>See Aygören-Pürsün 2017</p> <p>Patients received 500U and 1000 U prophylactic injection of Cinryze every 3 to 4 days for 12 weeks. Subjects were randomized to either</p>	<p>See Aygören-Pürsün 2017</p>	<p>Median age, years [range] 18 [13.1-28.2]</p> <p>Female, n (%) 7 (58.3)</p> <p>HAE type I, n (%) 12 (100)</p>	<p>Mean normalized number of attacks After 12 weeks observation: 3.7 (3.2)</p> <p>The mean percentage reduction in NNA compared to baseline, % (SD) 500U: 71.1 (27.1) 1000U: 84.5 (20.0)</p>	<p>Not reported</p>

Author & Year of Publication (Trial Name) Quality Rating	Study Design and Duration of Follow-Up	Interventions (n) & Dosing Schedule	Inclusion and Exclusion Criteria	Patient Characteristics	Outcomes	Harms
		500 units or 1000 units of Cinryze during the first period. For the second period, patients switched to the alternative dose for another 12 weeks. Total N = 12		BMI, kg/m² (range) 18.6 (13.1-28.2)	The percentage of patients achieved ≥70% reduction from baseline, % 500U: 58.3 1000U: 91.7	
Bernstein <i>Allergy Clin Immun</i> 2014⁷² Fair	Single-arm study 25 weeks (12-week treatment period, 13-week follow-up period)	1) 1500 Cinryze, n=20 2) 2000 Cinryze, n=13 3) 2500 Cinryze, n=12 Patients received 1500 IU in the first dosage step, and then escalated to the next dosage group depending on the reaction and tolerance	Inclusions: ≥6 years with a confirmed diagnosis of HAE, weighted ≥25 kg, had an average of >1.0 attack/month, regardless of severity, in the 3 months before the study Exclusion Had a history of abnormal blood clotting, used prescription anticoagulant medication, had a history of allergic reaction to C1-INH-ng or similar products	Mean age, years (SD) 41.7 (15.3) Female, n (%) 14 (70) Mean female BMI, kg/m² (SD) 30.2 (6.7) Mean male BMI, kg/m² (SD) 33.1 (5.5) White, n (%) 18 (90) Average number of HAE attacks per month during the year before enrollment, mean (SD) 4.4 (3.1) Distribution of the average number monthly attacks during the year before enrollment (SD) 1-3 attacks/month: 10 (50) >3 attacks/month: 10 (50) Number of hospital visits necessary for HAE attacks	Mean days of exposure duration, days (SD) 1) 101 (42.2) 2) 78 (15.2) 3) 124 (43.5) The number of patients achieved per-protocol treatment success (an average monthly attack rate of ≤1.0 at week 12), n (%) Cinryze prophylaxis: 9 (45) The number of patients achieved investigator-determined success, n (%) Cinryze prophylaxis: 2 (10) The number of patients experienced a reduction in >1.0 attack per month, n (%) Cinryze prophylaxis: 3 (15)	No serious AEs or discontinuation related to the treatment Patients with ≥1 AEs, n (%) 1) 15 (75) 2) 11 (85) 3) 11 (92) Patients with SAEs, n (%) 1) 1 (5) 2) 1(8) 3) 1(8) Discontinuation due to AEs, n (%) 1) 0 2) 0 3) 0 Thrombotic event, n (%) 1) 0 2) 0 3) 0 Most frequent AEs: -Upper Respiratory Tract Infection

Author & Year of Publication (Trial Name) Quality Rating	Study Design and Duration of Follow-Up	Interventions (n) & Dosing Schedule	Inclusion and Exclusion Criteria	Patient Characteristics	Outcomes	Harms
				during the year before enrollment, mean (SD) 1.7 (3.3)		-Nasopharyngitis
Haegarda						
<p>Longhurst NEJM 2017²⁹</p> <p>[COMPACT]</p> <p>NCT01912456</p> <p>Good</p>	<p>Phase III, randomized, double-blind, placebo-controlled, dose-ranging, multicenter, crossover study</p> <p>32 weeks (two 16-week treatment periods, after a 2-week run-in period)</p>	<p>1) 40 IU Haegarda followed by placebo, n=45</p> <p>2) 60 IU Haegarda followed by placebo, n=45</p> <p>Total N = 90 (79 completed)</p> <p>The patients were randomly assigned in a 1:1:1:1 ratio to receive Haegarda at a dose of 40 IU per kg of body weight during the first 16-week treatment period followed by placebo for the second 16-week treatment period, or vice versa.</p>	<p>Inclusions:</p> <p>≥12 years with a confirmed diagnosis of HAE, a functional C1-INH level <50% of normal levels, and have ≥4 attacks per month for at least 3 consecutive months</p> <p>Exclusion</p> <p>Allergenic to rabbits or with a diagnosis of acquired angioedema, pregnant or breastfeeding mothers, and patients receiving angiotensin-converting enzyme inhibitors</p>	<p>Mean Age, years (SD)</p> <p>1) 42.4 (14.4) 2) 36.8 (14.9)</p> <p>Mean weight, kg (SD)</p> <p>1) 83.0 (23.0) 2) 80.2 (24.6)</p> <p>HAE type II, n (%)</p> <p>1) 4 (9.0) 2) 8 (18.0)</p> <p>The number of HAE attacks in the preceding 3 months, n (SD)</p> <p>1) 10.8 (6.7) 2) 8.8 (6.4)</p> <p>Use of prophylaxis against HAE attacks in the preceding 3 months, n (%)</p> <p>1) 16 (36.0) 2) 22 (49.0)</p> <p>Use of plasma-derived C1-INH against HAE attacks in the preceding 3 months, n (%)</p> <p>1) 9 (20.0) 2) 14 (31.0)</p> <p>Use of danazol as oral prophylaxis against HAE</p>	<p><i>All outcomes reported versus placebo</i></p> <p>The mean number of time-normalized attacks per month, n [95% CI]</p> <p>1) 1.19 [0.54-1.85] vs. 3.61 [2.96-4.26] 2) 0.52 [0.00-4.55] vs. 4.03 [3.51-4.55]</p> <p>Patients with a response, % [95% CI] ≥50% reduction in attacks vs. placebo</p> <p>1) 76 [62-87] 2) 90 [77-96]</p> <p>≥70% reduction in attacks vs. placebo</p> <p>1) 67 [52-79] 2) 83 [68-91]</p> <p>≥90% reduction in attacks vs. placebo</p> <p>1) 43 [29-58] 2) 58 [42-72]</p> <p>Number of days of HAE symptoms per month, n (SD) vs. placebo</p> <p>1) 1.57 (2.64) vs. 7.00 (5.75) 2) 1.61 (4.39) vs. 7.51 (5.59)</p> <p>Use of rescue medication [95% CI]</p> <p>1) 1.13 [-1.44-3.69] vs. 5.55 [3.10-8.00] 2) 0.32 [-0.33-0.97] vs. 3.89 [3.23-4.55]</p> <p>Average attack severity score (SD)</p> <p>1) 1.77 (0.59) vs. 2.03 (0.49) 2) 1.64 (0.56) vs. 1.94 (0.47)</p>	<p>AE lead to discontinuation, n (%)</p> <p>1) 0 (0) 2) 2 (5)</p> <p>Serious AEs, n (%)</p> <p>1) 1 (2) 2) 0 (0)</p> <p>Any AEs in ≥ 5% of patients</p> <p>Injection-site reaction, n (%)</p> <p>1) 12 (28) 2) 15 (35)</p> <p>Nasopharyngitis, n (%)</p> <p>1) 1 (2) 2) 8 (19)</p> <p>Upper-respiratory-tract infection, n (%)</p> <p>1) 3 (7) 2) 3 (7)</p> <p>Hypersensitivity, n (%)</p> <p>1) 2 (5) 2) 3 (7)</p> <p>Dizziness, n (%)</p> <p>1) 4 (9) 2) 0 (0)</p>

Author & Year of Publication (Trial Name) Quality Rating	Study Design and Duration of Follow-Up	Interventions (n) & Dosing Schedule	Inclusion and Exclusion Criteria	Patient Characteristics	Outcomes	Harms
				attacks in the preceding 3 months, n (%) 1) 6 (13.0) 2) 10 (22.0)		
Lumry Allergy Asthma Immunol 2017⁹¹ [COMPACT] Conference Abstract – Additional outcome NCT01912456 <u>Main Trial:</u> Longhurst 2017 ²⁹	Phase III, randomized, double-blind, placebo-controlled, dose-ranging, multicenter, crossover study 32 weeks (two 16-week treatment periods, after a 2-week run-in period)	1) 40 IU Haegarda followed by placebo, n=45 2) 60 IU Haegarda followed by placebo, n=45	See Longhurst 2017	See Longhurst 2017	Breakthrough attacks: Overall: n=1191 (913 were treated with rescue medications) Combined Haegarda doses: 18% Combined placebo: 82% Percent of treated attacks: 60 IU/kg Haegarda: 49% Corresponding placebo: 75% 40 IU/kg Haegarda: 68% Corresponding placebo: 83% Median treated attacks/month: 60 IU/kg Haegarda: 0 Corresponding placebo: 2.5 40 IU/kg Haegarda: 0.3 Corresponding placebo: 2.8 90% of treated attacks and all treated attacks on 60 IU/kg were treated with only 1 injection of any rescue medication	See Longhurst 2017
Longhurst Allergy 2017¹⁰⁸ [COMPACT] Conference Abstract – Long-term extension NCT01912456 <u>Main Trial:</u> Longhurst 2017 ²⁹	See Longhurst 2017 above Extension study.	1) 40 IU Haegarda (15) 2) 60 IU Haegarda (14) 64 of 126 patients from the pivotal trial were randomized equally to receive 40 IU/kg or 60 IU/kg Haegarda. Dose increments of 20 IU/kg (to a max of 80 IU/kg) were permitted for frequent HAE attacks	Not reported	Not reported	The median (interquartile range, IQR) HAE attacks/month: <u>Pivotal study:</u> 1) 0.29 (0.00, 1.19) 2) 0.29 (0.00, 0.60) <u>With-in patients' difference between the 2 studies:</u> (extension minus pivotal study) 1) 0.02 (-0.46, 0.20), n=15 2) 0.00 (-0.10, 0.20), n=14 *The difference is not clinically relevant	Not reported

Author & Year of Publication (Trial Name) Quality Rating	Study Design and Duration of Follow-Up	Interventions (n) & Dosing Schedule	Inclusion and Exclusion Criteria	Patient Characteristics	Outcomes	Harms
					Dose escalation 1) 12 patients stayed on assigned dose; 3 patients were up-titrated to 60 IU/kg; and 1 was further up-titrated to 80 IU/kg 2) All patients were maintained at 60 IU/kg	
Tarzi Allergy 2017¹⁰⁹ [COMPACT] Conference Abstract – Additional outcome NCT01912456 <u>Main Trial:</u> Longhurst 2017²⁹	See Longhurst 2017 above	See Longhurst 2017 above	See Longhurst 2017 above	See Longhurst 2017 above	The number of patients had at least 1 HAE attack, n (%) 1) 26 (57.8) 2) 25 (55.5) Low-volume placebo: 42 (93.3) High-volume placebo: 40 (88.9) The number of patients had at least 1 severe attack, n (%) 1) 9 (20.0) 2) 4 (8.9) Low-volume placebo: 31 (68.9) High-volume placebo: 33 (73.3) The proportion of patients had at least 1 moderate attack, % 1) 26.7 2) 28.9 The proportion of patients had at least 1 mild attack, % 1) 11.1 2) 17.8	Not reported
Lumry Allergy Asthma Immunol 2017⁷⁹ [COMPACT] Conference Abstract – Quality of life outcome NCT01912456	See Longhurst 2017 above	See Longhurst 2017 above	See Longhurst 2017 above	See Longhurst 2017 above	Anxiety HADS domain scores Treatment differences between Haegarda (combined doses) vs. placebo [95%CI] -1.05 [-1.79 to -0.31] Work Productivity Loss domains of Presenteeism	See Longhurst 2017 above

Author & Year of Publication (Trial Name) Quality Rating	Study Design and Duration of Follow-Up	Interventions (n) & Dosing Schedule	Inclusion and Exclusion Criteria	Patient Characteristics	Outcomes	Harms
Main Trial: Longhurst 2017 ²⁹					<p>Treatment differences between Haegarda (combined doses) vs. placebo [95%CI] -15.86 [-25.21 to -6.52]</p> <p>Work productivity loss Treatment differences between Haegarda (combined doses) vs. placebo [95%CI] -19.97 [-30.84 to -9.10]</p> <p>Activity impairment Treatment differences between Haegarda (combined doses) vs. placebo [95%CI] -19.83 [-27.28 to -11.88]</p>	
Longhurst Allergy Clin Immunol 2017¹¹⁰ [COMPACT] Conference Abstract – Additional outcome NCT01912456 Main Trial: Longhurst 2017 ²⁹	See Longhurst 2017 above	See Longhurst 2017 above	See Longhurst 2017 above	See Longhurst 2017 above	<p>Pooled results</p> <p>Treatment Satisfaction Questionnaire for Medication Effectiveness Mean difference between combined doses of Haegarda vs placebo [95%CI]: 37.07 [24.86, 49.28]</p> <p>The percentage of subjects received a rating of “good or excellent” response on: <u>The Investigator’s Global Assessment of Response to Therapy, %</u> 1) Combined doses of Haegarda: 80.0% 2) Placebo: 12.2%</p> <p><u>The Subject’s Global Assessment of Response to Therapy, %</u> 1) Combined doses of Haegarda: 75.6% 2) Placebo: 23.3%</p>	See Longhurst 2017 above
Craig Allergy Clin Immunol 2017¹¹¹	See Longhurst 2017 above	See Longhurst 2017 above	See Longhurst 2017 above	See Longhurst 2017 above	<p>Mean time-normalized HAE monthly attack rate (SD) Haegarda: 1.73 (2.902)</p>	See Longhurst 2017 above

Author & Year of Publication (Trial Name) Quality Rating	Study Design and Duration of Follow-Up	Interventions (n) & Dosing Schedule	Inclusion and Exclusion Criteria	Patient Characteristics	Outcomes	Harms
<p>[COMPACT]</p> <p>Conference Abstract – Subgroup analysis</p> <p>NCT01912456</p> <p>Main Trial: Longhurst 2017²⁹</p>	Pre-specified subgroup analysis of 22 subjects who used C1-INH(IV) for routine prophylaxis of HAE attacks prior to using C1-INH(SC) during COMPACT trial participation. Patients were followed up for 3 months prior to the start of COMPACT trial	N=22			<p>During pre-study use of C1-INH: 2.56 (2.58)</p> <p>Mean percentage reduction in HAE attack rate vs. pre-study prophylactic C1-INH (IV) use, % (SD)</p> <p>Both Haegarda doses: 52.1% (63.64%)</p> <p>By doses:</p> <p>40 IU Haegarda: 40.8 (68.37%)</p> <p>60 IU Haegarda: 53.7 (64.23%)</p>	
Lanadelumab						
<p>Banerji <i>Allergy Asthma</i> 2017³⁰</p> <p>[HELP]</p> <p>Conference Abstract</p> <p>NCT02586805</p>	<p>Phase III, randomized, double-blind, placebo-controlled, multicenter, parallel arm study</p> <p>32 weeks (26-week treatment period and a 4-week run-in period)</p>	<p>1) Placebo, n=41</p> <p>2) 150 mg Lanadelumab q4wks, n=28</p> <p>3) 300 mg Lanadelumab q4wks, n=29</p> <p>4) 300 mg Lanadelumab q2wks, n=27</p> <p>Total N = 125 (113 completed)</p>	Not reported	<p>Mean age, years 40.7</p> <p>Female, % 70.4</p> <p>White, % 90.4</p> <p>Patients reported ≥3 attacks per month, % 52</p>	<p>Mean monthly attack rate, % change vs. placebo [95%CI]</p> <p>Attack from day 0 to 182</p> <p>1) 1.97</p> <p>2) 0.48, -75.6% [-84.7% to -61.2%]</p> <p>3) 0.53, -73.3% [-82.4% to -59.5%]</p> <p>2) 0.28, -86.9% [-92.8% to -78.2%]</p> <p>Attack that required acute treatment</p> <p>1) 1.64</p> <p>2) 0.31, -80.8% [-80.2% to -66.1%]</p> <p>3) 0.42, -74.2% [-83.7% to -59.0%]</p> <p>2) 0.21, -87.3% [-93.5% to -75.2%]</p> <p>Moderate and severe attacks</p> <p>1) 1.22</p> <p>2) 0.36, -70.5% [-82.7% to -49.7%]</p> <p>3) 0.32, -73.3% [-84.3% to -54.5%]</p> <p>2) 0.20, -83.4% [-91.6% to -67.1%]</p> <p>Attacks from day 14 to 182</p> <p>1) 1.99</p> <p>2) 0.44, -77.6% [-86.3% to -63.6%]</p> <p>3) 0.49, 75.4% [-84.1% to -61.8%]</p> <p>2) 0.22, -89.0% [-94.3% to -78.7%]</p>	<p>Injection site pain, %</p> <p>Placebo group = 29.3</p> <p>Lanadelumab group = 42.9</p> <p>Headache, %</p> <p>Placebo group = 19.5</p> <p>Lanadelumab group = 20.2</p> <p>Viral upper respiratory tract injection, %</p> <p>Placebo group = 26.8</p> <p>Lanadelumab group = 23.8</p>

Author & Year of Publication (Trial Name) Quality Rating	Study Design and Duration of Follow-Up	Interventions (n) & Dosing Schedule	Inclusion and Exclusion Criteria	Patient Characteristics	Outcomes	Harms
					<p>Percentage of attack-free patients</p> <p>1) 2.4 2) 39.3 3) 31.0 4) 44.4</p>	
<p>Lumry J <i>Allergy Clin Immunol Pract</i> 2018⁸¹</p> <p>[HELP]</p> <p>Conference Abstract</p> <p>NCT02586805</p> <p><u>Main Trial:</u> Banerji <i>Allergy Asthma</i> 2017³⁰</p>	See Banerji 2017	<p>1) Placebo, n=41</p> <p>2) 150 mg Lanadelumab q4wks, n=28</p> <p>3) 300 mg Lanadelumab q4wks, n=29</p> <p>4) 300 mg Lanadelumab q2wks, n=27</p> <p>Total N = 125 (113 completed)</p>	See Banerji <i>Allergy Asthma</i> 2017	See Banerji <i>Allergy Asthma</i> 2017	<p><u>Lanadelumab groups were pooled</u></p> <p>Mean change in AE-QoL scores: functioning domain (SD)</p> <p>1-3) Lanadelumab: -29.29 (22.88) 4) Placebo: -5.41 (22.92) P<0.01</p> <p>The proportion of patients achieved a MCID in total score, %</p> <p>1-3) Lanadelumab: 70 4) Placebo: 37 P<0.001</p> <p>Specifically, patients in 300mg q4wks, 150mg 14wks, and 300mg q2wks of Lanadelumab group were 2.9, 3.2, and 7.2 times more likely to achieve the MCID in total scores compared to placebo group</p>	See Banerji <i>Allergy Asthma</i> 2017
<p>Riedl <i>Allergy Clin Immunol Pract</i> 2018⁷⁶</p> <p>[HELP]</p> <p>Conference Abstract</p> <p>NCT02586805</p> <p>Banerji <i>Allergy Asthma</i> 2017³⁰</p>	See Banerji 2017	<p>1) Placebo, n=41</p> <p>2) 150 mg Lanadelumab q4wks, n=28</p> <p>3) 300 mg Lanadelumab q4wks, n=29</p> <p>4) 300 mg Lanadelumab q2wks, n=27</p> <p>Total N = 125 (113 completed)</p>	See Banerji <i>Allergy Asthma</i> 2017	See Banerji <i>Allergy Asthma</i> 2017	<p>Reduction in mean attack rate, % p-value</p> <p><u>For patients had baseline attacks rates of 1 to <2 attack per month (n=38):</u></p> <p>1) placebo data not reported 2) 51.0, p=0.055 3) 80.4, p=0.003 4) 92.8, p=0.009</p> <p><u>For patients had baseline attacks rates of 2 to <3 attacks per month (n=22):</u></p> <p>1) placebo data not reported 2) 90.6, p=0.001 3) 77.0, p=0.001</p>	See Banerji <i>Allergy Asthma</i> 2017

Author & Year of Publication (Trial Name) Quality Rating	Study Design and Duration of Follow-Up	Interventions (n) & Dosing Schedule	Inclusion and Exclusion Criteria	Patient Characteristics	Outcomes	Harms
					<p>4) 88.2, p=0.001</p> <p><u>For patients had baseline attacks rates of >3 attacks per month (n=65):</u></p> <p>1) placebo data not reported</p> <p>2) 78.8, p=0.001</p> <p>3) 70.8, p=0.001</p> <p>4) 85.9, p=0.001</p>	
<p>Johnston <i>Allergy Clin Immunol Pract</i> 2018⁷⁷</p> <p>[HELP]</p> <p>Conference Abstract</p> <p>NCT02586805</p> <p>Banerji <i>Allergy Asthma</i> 2017³⁰</p>	See Banerji 2017	<p><u>Among patients that used C1-INH in the past:</u></p> <p>1) Placebo, n=22</p> <p>2) 150 mg Lanadelumab q4wks, n=9</p> <p>3) 300 mg Lanadelumab q4wks, n=18</p> <p>4) 300 mg Lanadelumab q2wks, n=11</p> <p><u>Among patients that were never on LTP:</u></p> <p>1) Placebo, n=17</p> <p>2) 150 mg Lanadelumab q4wks, n=16</p> <p>3) 300 mg Lanadelumab q4wks, n=9</p> <p>4) 300 mg Lanadelumab q2wks, n=13</p>	See Banerji <i>Allergy Asthma</i> 2017	See Banerji <i>Allergy Asthma</i> 2017	<p>Mean monthly attack rate, % change vs. placebo [95%CI]</p> <p><u>Among patients that used C1-INH in the past:</u></p> <p>1) 2.16</p> <p>2) 0.57, -73.6% [-87.4% to -44.8%]</p> <p>3) 0.61, -71.6% [-83.1% to -52.4%]</p> <p>4) 0.38, -82.5% [-91.7% to -62.9%]</p> <p>All p values vs. placebo<0.001</p> <p><u>Among patients that were never on LTP:</u></p> <p>1) 1.76</p> <p>2) 0.44, -74.8% [-87.0% to -51.1%]</p> <p>3) 0.39, -77.8% [-90.2% to -49.4%]</p> <p>4) 0.20, -88.5% [-96.3% to -64.3%]</p> <p>All p values vs. placebo<0.001</p>	See Banerji <i>Allergy Asthma</i> 2017

Appendix E. Comparative Value Supplemental Information

Table E1. Impact Inventory

Sector	Type of Impact (Add Additional Domains, as Relevant)	Included in this Analysis from... Perspective?		Notes on Sources (if quantified), Likely Magnitude & Impact (if Not)
		Health Care Sector	Societal	
Formal Health Care Sector				
Health Outcomes	Longevity effects	X	X	
	Health-related quality of life effects	X	X	
	Adverse events	X	X	
Medical costs	Paid by third-party payers	X	X	
	Paid by patients out-of-pocket	<input type="checkbox"/>	<input type="checkbox"/>	
	Future related medical costs	<input type="checkbox"/>	X	
	Future unrelated medical costs	<input type="checkbox"/>	<input type="checkbox"/>	
Informal Health Care Sector				
Health-Related Costs	Patient time costs	NA	X	
	Unpaid caregiver-time costs	NA	<input type="checkbox"/>	
	Transportation costs	NA	<input type="checkbox"/>	
Non-Health Care Sectors				
Productivity	Labor market earnings lost	NA	X	
	Cost of unpaid lost productivity due to illness	NA	X	
	Cost of uncompensated household production	NA	<input type="checkbox"/>	
Consumption	Future consumption unrelated to health	NA	<input type="checkbox"/>	
Social Services	Cost of social services as part of intervention	NA	<input type="checkbox"/>	
Legal/Criminal Justice	Number of crimes related to intervention	NA	<input type="checkbox"/>	
	Cost of crimes related to intervention	NA	<input type="checkbox"/>	
Education	Impact of intervention on educational achievement of population	NA	<input type="checkbox"/>	
Housing	Cost of home improvements, remediation	NA	<input type="checkbox"/>	
Environment	Production of toxic waste pollution by intervention	NA	<input type="checkbox"/>	
Other	Other impacts (if relevant)	NA	<input type="checkbox"/>	

NA: not applicable

Adapted from Sanders et al.¹¹²

Figure E1. Probabilistic Sensitivity Analysis Results: Cost-Effectiveness Cloud

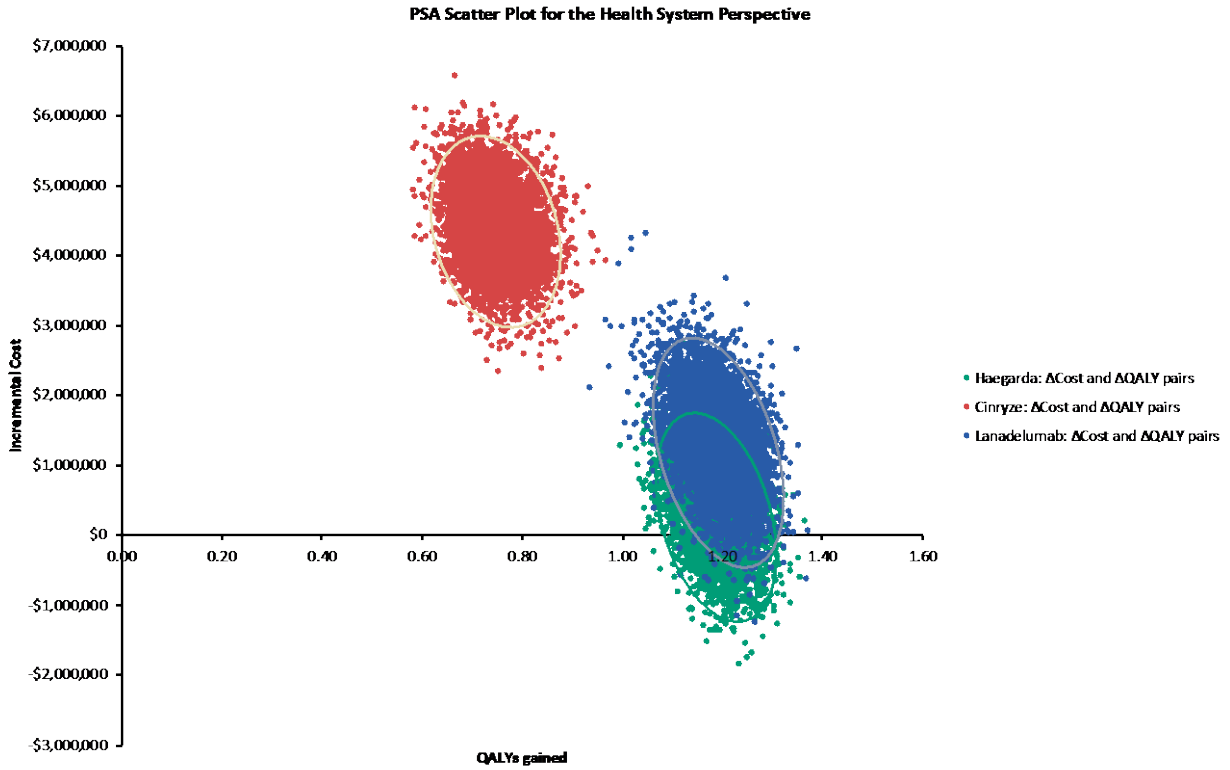

Ellipse is the 95% confidence ellipse

Table E2. Results for the Modified Societal Perspective

	No Prophylaxis	Cinryze	Haegarda	Lanadelumab
Total Costs – Modified Societal Perspective	\$10,104,000	\$14,471,000	\$10,361,000	\$11,293,000
QALYs	17.47	18.21	18.65	18.66
# of Attacks	1703	927	273	223

*Costs are rounded to the nearest \$1,000.

Table E3. Incremental Results versus No Prophylaxis for the Modified Societal Perspective

	Cinryze	Haegarda	Lanadelumab
Total Costs – Modified Societal Perspective	\$4,367,000	\$257,000	\$1,189,000
QALYs Gained	0.75	1.19	1.19
# of Attacks Avoided	860	1,430	1,480
Incremental Cost-Effectiveness Ratio – Modified Societal Perspective	\$5,852,000	\$216,000	\$998,000
\$/Attack Avoided - Modified Societal Perspective	\$5,079	\$180	\$804

*Incremental cost-effectiveness ratios are rounded to the nearest \$1,000; incremental cost-effectiveness ratios are rounded to the nearest \$10,000 when over \$1 million.

Table E4. Results at Wholesale Acquisition Costs

	No Prophylaxis	Cinryze	Haegarda	Lanadelumab
Total Costs – US Health System Perspective	\$12,515,000	\$18,863,000	\$13,898,000	\$14,958,000
Prophylaxis Drug Costs	\$0	\$12,668,000	\$12,005,000	\$13,319,000
Acute Treatment Costs	\$12,515,000	\$6,916,000	\$1,893,000	\$1,640,000
Acute Treatment Costs (Drugs)	\$11,767,000	\$5,825,000	\$1,838,000	\$1,542,000
Acute Treatment Costs (Other services)	\$748,000	\$370,000	\$55,000	\$98,000
LYs	23.55	23.55	23.55	23.55
QALYs	17.47	18.21	18.65	18.66
# of Attacks	1,703	843	273	223

*Costs are rounded to the nearest \$1,000.

Table E5. Incremental Results versus No Prophylaxis at Wholesale Acquisition Costs

	Cinryze	Haegarda	Lanadelumab
Total Costs – US Health System Perspective	\$6,348,000	\$1,383,000	\$2,443,000
Prophylaxis Drug Costs	\$12,668,000	\$12,005,000	\$13,319,000
Acute Treatment Costs	-\$6,319,000	-\$10,622,000	-\$10,875,000
Acute Treatment Costs (Drugs)	-\$5,942,000	-\$9,929,000	-\$10,225,000
Acute Treatment Costs (Other Services)	-\$378,000	-\$693,000	-\$650,000
LYs Gained	0.00	0.00	0.00
QALYs Gained	0.75	1.19	1.19
# of Attacks Avoided	860	1,430	1,480
ICER – US Health System Perspective	\$8,507,000	\$1,165,000	\$2,051,000
\$/Attack Avoided - US Health System Perspective	\$7,383	\$967	\$1,651

*Incremental cost-effectiveness ratios are rounded to the nearest \$1,000; incremental cost-effectiveness ratios are rounded to the nearest \$10,000 when over \$1 million.

Appendix F. Public Comments

This section includes a summary of the public comment prepared for the CTAF Public Meeting on October 25, 2018 in Oakland, California. This summary was prepared by the speaker who delivered the public comment at the meeting. A video recording of all comments can be found here: <https://www.youtube.com/watch?v=i35Ky1vIOk8>, beginning at 01:24:00. Conflict of interest disclosures are included at the bottom of each statement for each speaker who is not employed by a pharmaceutical manufacturer.

Debra Bensen-Kennedy, MD, CSL Behring
Vice President, Medical Affairs

CSL Behring's mission is to discover, develop, and deliver innovative therapies that improve patients' quality of life. We believe it is important that patients have access to all innovative therapies.

HAEGARDA[®], C1 Esterase Inhibitor Subcutaneous (Human), is the only C1-INH subcutaneous injection for the prevention of HAE attacks. The World Allergy Organization guidelines recommend use of C1-INH as first line long-term prophylaxis and as the preferred therapy for HAE attacks during pregnancy and lactation.¹

CSL Behring agrees with ICER's conclusion that HAEGARDA is an efficacious and safe therapy, and is cost-effective when compared to other agents for the prevention of HAE attacks. In the 60 IU/kg treatment arm of the pivotal trial, HAEGARDA demonstrated a 95% median reduction of attacks compared to placebo and a >99% median reduction in number of uses of rescue medication compared to placebo.²

As previously discussed with ICER, there remain a few key limitations to the report:

The baseline monthly attack rate and on-demand therapy re-dosing frequencies utilized in the model are lower than certain published data and may not reflect real world clinical experience.

The Q4W dosing scenario for lanadelumab lacks clinical and scientific evidence and therefore should be clearly disclosed as speculative and unlikely. A re-evaluation that incorporates real world evidence should be considered in the future.

The statement on wastage is not reflective of clinical or real world experience. The HAEGARDA pivotal trial planned dosage and patient-recorded dosage were essentially the same. Current HAEGARDA patient data for overall mean consumption dose conflicts with ICER's assumption.

CSL Behring is committed to making available real-world evidence to demonstrate the clinical and economic value of HAEGARDA.

¹ Maurer M, Magerl M, Ansotegui I, et al. The international WAO/EAACI guideline for the management of hereditary angioedema – the 2017 revision and update. *Allergy*. 2018. doi: 10.1111/all.13384.

² Longhurst H, Cicardi M, Craig T, et al. Prevention of hereditary angioedema attacks with a subcutaneous C1 inhibitor. *N Engl J Med*. 2017;376(12):1131-1139.

Appendix G. Conflict of Interest Disclosures

Tables G1 through G3 contain conflict of interest (COI) disclosures for all participants at the October 25, 2018 Public meeting of CTAF.

Table G1. ICER Staff and Consultant COI Disclosures

Name	Organization	Disclosures
Foluso Agboola, MBBS, MPH	ICER	None
Laura Cianciolo, BA	ICER	None
Grace A. Lin, MD, MAS,	UCSF	None
Solomon Lubinga, PhD, MSc	UW	None
Steve Pearson MD, MSc	ICER	None
David Rind, MD, MSc	ICER	None
Matthew Seidner, BS	ICER	None
David Whitrap, BA, BES,	ICER	None

Table G2. CTAF Panel Member COI Disclosures

Name	Organization	Disclosures
Felicia Cohn, PhD	Kaiser Permanente, Orange County	*
Robert Collyar	Patient Advocate	*
Rena K. Fox, MD	University of California, San Francisco	*
Kimberly Gregory, MD, MPH	Cedars-Sinai Medical Center	*
Paul Heidenreich, MD, MS	Stanford University	*
Jeffrey Hoch, PhD	University of California, Davis	*
Jeffrey Klingman, MD	The Permanente Medical Group	*
Annette Langer-Gould, MD, PhD	Southern California Permanente Medical Group, Kaiser Permanente	*
Joy Melnikow, MD, MPH	University of California, Davis	*
Elizabeth J. Murphy, MD, DPhil	Zuckerberg San Francisco General Hospital	*
Patricia E. Powers, MPA	Center for Healthcare Decisions (UC Davis)	*
Rita F. Redberg, MD, MSc, FACC	University of California, San Francisco School of Medicine	*
William Remak, BSc, MT, BPH	California Hepatitis C Task Force	*
Robert Rentschler, MD,	Retired, Beaver Medical Group	*
Alexander Smith, MD, MPH	University of California, San Francisco	*

*No conflicts of interest to disclose, defined as individual health care stock ownership (including anyone in the member's household) in any company with a product under study, including comparators, at the meeting in excess of \$10,000 during the previous year, or any health care consultancy income from the manufacturer of the product or comparators being evaluated.

Table G3. Policy Roundtable Participant COI Disclosures

Name	Title and Affiliation	Disclosures
Debra Bensen-Kennedy, MD	Vice President, Medical Affairs, CSL Behring	Full-time employee of CSL Behring.
Marco Cicardi, MD	Professor of Medicine, Università degli Studi di Milano, Italy	Received consultancy fees from Shire and CSL Behring; speaker for Shire, CSL Behring, and Pharming; received research and educational support from Shire and Pharming; principal investigator in lanadelumab, Ruconest, and Haegarda clinical trials.
April Kunze, PharmD	Senior Director, Formulary Development and Trend Management Strategy, Prime Therapeutics	Full-time employee of Prime Therapeutics.
Stephanie Smith	Patient Advocate	Receives honoraria for work as a patient advocate for Haegarda and CSL Behring