

**Technical Report No. IRL 1110**

**CYTOCHEMICAL STUDIES OF PLANETARY MICROORGANISMS  
EXPLORATIONS IN EXOBIOLOGY**

**Summary Report Covering Period July 1, 1969, to July 1, 1970  
For  
National Aeronautics and Space Administration  
Grant NGR-05-020-004**



**Instrumentation Research Laboratory, Department of Genetics  
Stanford University School of Medicine  
Stanford, California 94305**

Report to the National Aeronautics and Space Administration  
"Cytochemical Studies of Planetary Microorganisms - Explorations in Exobiology"

NGR 05-020-004

Summary Report Covering Period July 1, 1969 to July 1, 1970

Instrumentation Research Laboratory, Department of Genetics  
Stanford University School of Medicine  
Stanford, California

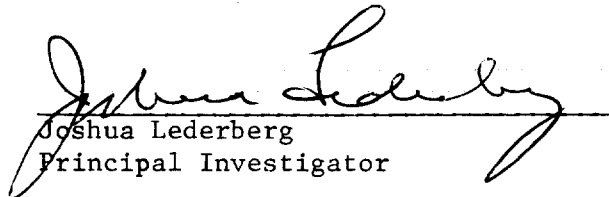
  
Joshua Lederberg  
Principal Investigator

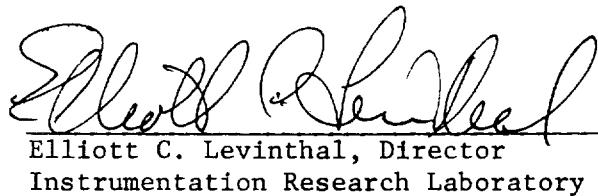
  
Elliott C. Levinthal, Director  
Instrumentation Research Laboratory

## A. INTRODUCTION

This report covers the activities of the Instrumentation Research Laboratory during the two quarter period from January 1, 1970 to July 1, 1970 and serves also as a summary annual report of our work for the year ending July 1, 1970.

While the main support of the IRL activities during this period continued to be the NASA grant NGR-05-020-004, some of the funds have come from other grants, other agencies, and in some cases private institutions. This report includes all the activities of the laboratory which relate to or have benefited from NASA support regardless of whether or not they were primarily supported by this NASA grant.

We have applied for funding for our work from other agencies, particularly the National Institutes of Health, with some degree of success, especially in the area of cell separation. Effective January 1, 1970 essentially all of our work in this area was supported by NIH grant GM 17367 and NIH Contract 69-2064. We have received some support for Dr. Halpern's work under NIH

Grant AM 12797 and are seeking additional support for his work on the interaction of chlorine compounds with DNA. Our work on computer aided instrumentation has been partially supported by a collaborative program with the Physics Department and their Air Force contract, AF F 44620 67C 0070. The efforts on image processing for the 1971 Mars Mariner are a joint effort with the Artificial Intelligence Laboratory of the Computer Science Department under Professor John McCarthy, Advanced Research Projects Agency grant SD 183

These interrelationships benefit our NASA program in two ways. They aid the rapid utilization for medicine, and biology in general, of the ideas and skills developed because of our interests in space missions. They not only provide us with the opportunity of testing instrumentation methods, applicable to future NASA programs, in circumstances of solving current scientific problems but also provides much needed additional support. This support hopefully will permit the Instrumentation Research Laboratory to continue to function with sufficient technological depth and breadth to allow responses to future NASA needs.

For these reasons we have felt it desirable to carry out some laboratory work that could lead to new fruitful relationships. A meeting on Space Bioscience - Technology Utilization held on November 28-30, 1969 under the auspices of the Interdisciplinary Communication Program, was attended by Professor Lederberg and Dr. Levinthal. This meeting reinforced our conviction that there are areas of environmental health that would be an intellectually challenging and socially productive use of our scientific and technological skills. During this reporting period we have begun to investigate such possibilities in environmental health, particularly in environmental monitoring.

The general areas of the program resume, Part B of the report, are:

Topic	Page
I. The Determination of Optical Activity by Gas Liquid Chromatography	5
II. Gas Chromatography of Amino Acids	6
III. The Reaction of Chlorine with DNA	7
IV. Apollo 11 and 12 Sample Analysis	9
V. The Mass Spectrometry of (1-phenylethyl)-Carbamates	10
VI. Analysis of Natural Products by Mass Spectrometry	11
VII. DENDRAL	13
VIII. Computer Aided Instrumentation	15
IX. Cell Separation	20
X. Optical Data Processing	25
XI. Quasi Microscope for Mars Lander	32
XII. Mariner Mars 1971 Orbiting Photography	34
XIII. Reports, Publications and Papers	36

## B. PROGRAM RESUME

### I. The Determination of Optical Activity by Gas Liquid Chromatography

As members of the team which is interested in the determination of optical activity of amino acids in planetary soils, we have collaborated with Ames personnel in the construction of a working model of a hydrolyser-desalter-derivatizer unit. A miniaturized version of such a unit will be compatible with the GC-MS-pyrolyser experiment proposed for the 1975 Viking mission.

Our chemical work on the GLC separation of diastereoisomers has been continued. Useful applications have been in the determination of optical purity of alcohols, ketones, phenylacetic acids and phenoxypropionic acids. This analytical technique has also been used to determine the absolute configuration of alloisoleucine present in the serum of a patient suffering from "Maple Syrup Urine disease".

## II. Gas Chromatography of Amino Acids

We have developed a simple technique, which permits the gas chromatography of some amino acids, without time consuming chemical manipulations. The procedure uses the injector port of a gas chromatograph as a chemical reactor. Since these conversions are concentration dependent, the injection port of a conventional chromatograph had to be modified to permit the removal of the solvent before the pyrolysis reaction. A prototype of a partially automated sample injection system has been constructed and the new procedure has been used to determine blood phenylalanines. A completely automated version of such an instrument should be of use in the routine screening of newborns for cases of phenylketonuria.



### III. The Reaction of Chlorine with DNA

Chlorine plays an indispensable role in the purification of our water supplies and urban settlement would be imperiled without chlorination. Despite our great dependence on the chlorine disinfection of water, the potential chronic toxicity to man from chlorine has not been considered a hazard, because chlorine is known to react rapidly with organics, which would lead to destruction of the reagent in the body fluids. This conclusion however ignores the possibility that the chlorine reacts with a variety of nitrogen containing compounds to form chloramines, which may themselves form potent chlorinating agents. Whilst there is an extensive literature on the stable end products of chlorination of the purines and pyrimidine bases and their nucleoside derivatives, chloramine derivatives of these compounds have not been described.

We have now examined the chlorination products obtained from cytosine and cytidine and find that they behave as typical chloramine derivatives. The compounds give a test for positive chlorine (Von Arx-Neher) and liberate iodine from KI solution. We have used the latter reaction to quantitatively estimate the amount of labile chlorine in the products. Under essentially the same experimental conditions and using between 0.01 to 10.0 equivalents of chlorox per base of DNA, we find that there is little change in the molecular weight of the "modified" DNA as

determined by sucrose gradient or elution on Sephadex 200. A large excess of chlorox leads to breakages of the DNA and the use of very concentrated solution of DNA results in the formation of some very high M.W. "modified" DNA.

#### IV. Apollo 11 and 12 Sample Analysis

Under Contract NAS 9-9439, we have examined the carbon compounds present in two samples of Apollo 11 and two samples of Apollo 12 for "porphyrin-like" pigments. Evidence for such compounds was obtained in Apollo 11 and 12 lunar fines. The pigments from samples collected near the lunar lander were probably due to contamination by rocket exhaust products. A porphyrin-like pigment ( $\sim 5 \times 10^{-5}$  g/g) was also found in an Apollo 12 sample which had been collected at a point well removed from the lunar landing site.

## V. The Mass Spectrometry of (1-Phenylethyl)-Carbamates

This class of organic compound was used for the optical analysis of asymmetric secondary alcohols. During this work several interesting features were noted in the mass spectra of these carbamates. In order to investigate the precise fragmentation modes of these molecules several deuterated compounds were synthesized. After studying the mass spectra of the carbamates labeled with deuterium it was possible to formulate rationalizations for the principal fragmentation processes including those hydrogen atoms transferred from one portion of the molecule to another. To avoid thermal decomposition it was necessary to use the direct inlet system and to maintain the ion source at temperatures below 160° or extensive thermal fragmentation of the carbamates resulted.

## VI. Analysis of Natural Products by Mass Spectrometer

During the past year research has continued on the structural analysis by mass spectrometry of natural products isolated from plant, animal and marine sources. A list of publications resulting from this experimentation follows:

1. "Mass Spectrometry in Structural and Stereochemical Problems - CLXXII: The Electron-Impact Prompted Fragmentation of 1,2-Cyclohexanediol" by M. Karen Strong and Carl Djerassi. Org. Mass Spectrometry 2, 631 (1969).
2. "Application of Ion Cyclotron Resonance to the Structure Elucidation of the  $C_3H_6O^+$  Ion Formed in the Double McLafferty Rearrangement" by George Eadon, John Diekman, Carl Djerassi. J. Am. Chem. Soc. 91, 3986 (1969)
3. "Mass Spectrometry in Structural and Stereochemical Problems CLXXVI. The Course of the Electron Impact Induced Fragmentation of Androstane" by L. Tokes and Carl Djerassi. J. Am. Chem. Soc. 91, 5017 (1969).
4. "Mass Spectrometry in Structural and Stereochemical Problems CLXXVIII. The Electron-Impact Promoted Fragmentation of 1,2-Cyclohexene Oxide" by M. K. Strong, P. Brown, C. Djerassi. Org. Mass Spectrometry 2, 1201 (1969).
5. "Mass Spectrometry in Structural and Stereochemical Problems CLXXIX. The Electron Impact Induced Rearrangements of 1-Phenylheptenes. Further Evidence for Double Bond Lability" by A. F. Gerrard and C. Djerassi. J. Am. Chem. Soc. 91, 6808 (1969).
6. "Mass Spectrometry in Structural and Stereochemical Problems. CLXXXIII. A Study of the Electron Impact Induced Fragmentation of Aliphatic Aldehydes" by R. J. Liedtke and C. Djerassi. J. Am. Chem. Soc. 91, 6814 (1969)

7. "Mass Spectrometry in Structural and Stereochemical Problems CLXXXII. Investigations in the 10-Phenyl-2-decalone System. The Synthesis and Electron Impact Promoted Phenyl Migration of trans-10-Phenyl-2-octalone" by R. T. Gray and C. Djerassi. J. Org. Chem. 35, 7533 (1970).
8. "Mass Spectrometry in Structural and Stereochemical Problems CLXXXI. Further Studies of Remote Group Interactions After Electron Impact in 4-Substituted Cyclohexanones" by R. T. Gray, R. J. Spangler and Carl Djerassi. J. Org. Chem. 35, 1525 (1970).
9. "Mass Spectrometry in Structural and Stereochemical Problems CLXXXIV. Charge Localization in Fragment Ions of Amino Ketones and Esters." J. Cable, G. W. Adelstein. Org. Mass Spectrometry 3, 439 (1970).

## VII. DENDRAL

During the past year, we have essentially completed phase 2 of the Dendral project, the demonstration of the utility of artificial intelligence as an aid in the solution of problems in analytical organic chemistry. (Phase 1, 1964-1967, was the system definition and general analysis of the problem of organic structures; Phase 2, 1968-70, has been the production and debugging of working computer programs.) A series of publications, some still in press, have exhibited the application of these methods to different classes of non-cyclic molecules. Ref. 32 also illustrates the extension of the program to some simpler cyclics and shows the feasibility of further extension. Ref. 33 is a general overview of the work to date. The procedures are worked out for data from mass-spectrometry, infra-red and NMR instrumentation.

We have now begun work on further phases.

Phase 3: "Meta-Dendral", a program whose output would be an encyclopedia of chemical reaction rules for the behavior of compounds in the mass spectrometer. Its input would be empirical data from compounds of known structure. This work is more revealing than DENDRAL itself is of the thought processes used by the chemist in inducing generalizations. It should also give a more reliable, self-consistent theory of mass spectrometry than is now available to DENDRAL from its human instructors. Fragments of the program have been written so far.

Phase 4: "Synthetic Dendral", a program to design and theoretically test reaction sequences for the synthesis of specific, desired end products. This has already been demonstrated in a preliminary running version.



### VIII. Computer Aided Research Instrumentation

The work in computer instrumentation of laboratory instruments, principally mass spectrometers, is undertaken primarily to investigate techniques applicable to exobiology missions. It supports much of the work described in this report and in addition has had application to several laboratories of this and other institutions, as well as civilian technology spin-off. The computer instrumentation has made use of ACME (Advanced Computer for Medical Research, a Stanford Medical School computer development utilizing an IBM 360/50) with an IBM 1800 to serve individual laboratory instrumentation tasks in a time shared mode. ACME is primarily supported by NIH grants, but here again a deliberate policy is followed to merge goals and grant resources with other research groups at Stanford to optimize joint objectives. These instrumentation developments have had notice and value beyond their use here at Stanford. They have been well reported in the scientific literature, the trade journals, and seminar papers. (Status reports have included bibliographies covering each reporting period.) Among these developments are a unique mass spectrometer control system (which now is available as a commercial product), mass spectrometer data processing systems, and a spectrophotometer data acquisition and processing system.

Much of our effort of scientific communication has been in

connection with the more general aspects of our work, namely the asynchronous time-shared use of a computer for simultaneous real time instrumentation in several different laboratories.

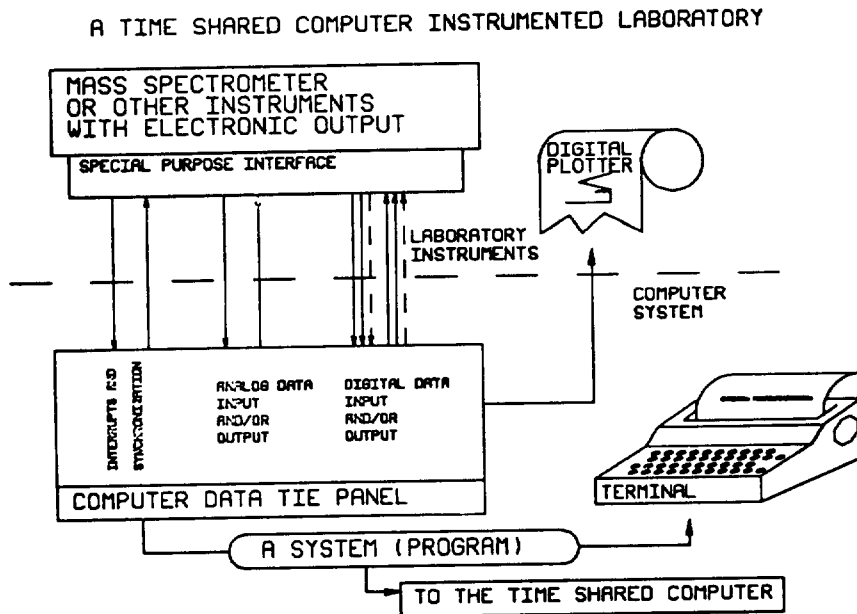

Figure 1. Typical laboratory instrumentation center contains computer data tie panel, keyboard terminal and graphic plotter.

Except for the special development, reported during the first half of this year, to support the lunar investigation of porphyrins by magnetic circular dichroism spectroscopy, this year has been characterized by the use and operation of computer systems started in prior reporting periods. A critical review of these projects has led to the definition of a new development we have now undertaken, the HIQ (High Intelligence Quotient) Terminal. This is described in more detail later in this section.

Figure 1 represents the basic features of a typical time-shared computer instrumentation problem. The specific design of these features affects the developmental cost and the degree of sophistication attainable. The choice of how much of the data channel (extending into the Computer Data Tie Panel in Figure 1) should be part of the computer system or the special purpose interface, the type of signal conditioning available to the user, the program language, and other variables all influence the level of computer assistance achieved by computer-managed instrumentation and its cost.

Over the last several years we have gained valuable experience in a variety of systems, ranging from a small stand-alone laboratory computer, such as the LINC, to a bare terminal connected to a remote large time-shared computer (ACME). This experience coupled with the development of less expensive "mini computers", has led to the concept of the "smart" terminal that provides local control for the instrument in the laboratory. This "terminal" with enough computer power to process the data stream allows a connection, using phone lines, to a larger computer system for maximum programming power, complex data manipulation, and large data-base filing. Our interest developed in a general modular design of such a terminal. Professor Melvin Schwartz of the Physics Department was led to a similar conclusion based on his instrumentation needs at SLAC (Stanford Linear Accelerator

# HIQ Time shared computer TERMINAL using DIGITAL PATHWAYS modules

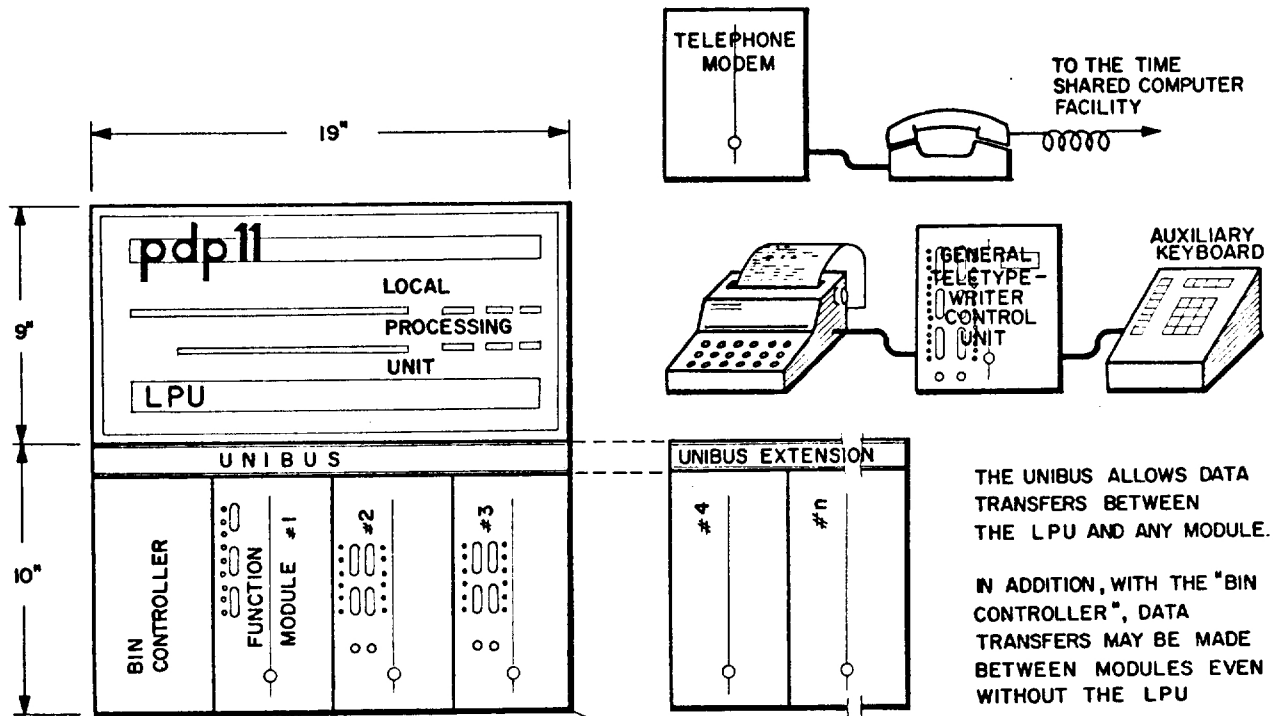

PLUG-IN MODULES INCLUDE DIGITAL INPUT, DIGITAL OUTPUT, A-to-D, D-to-A PLUS OTHERS ESPECIALLY SUITED TO LABORATORY SUPPORT OF MEDICAL, CLINICAL, BIOCHEMICAL, AND PHYSICS APPLICATIONS.

### SOME UNIQUE PLUG-IN MODULES ARE:

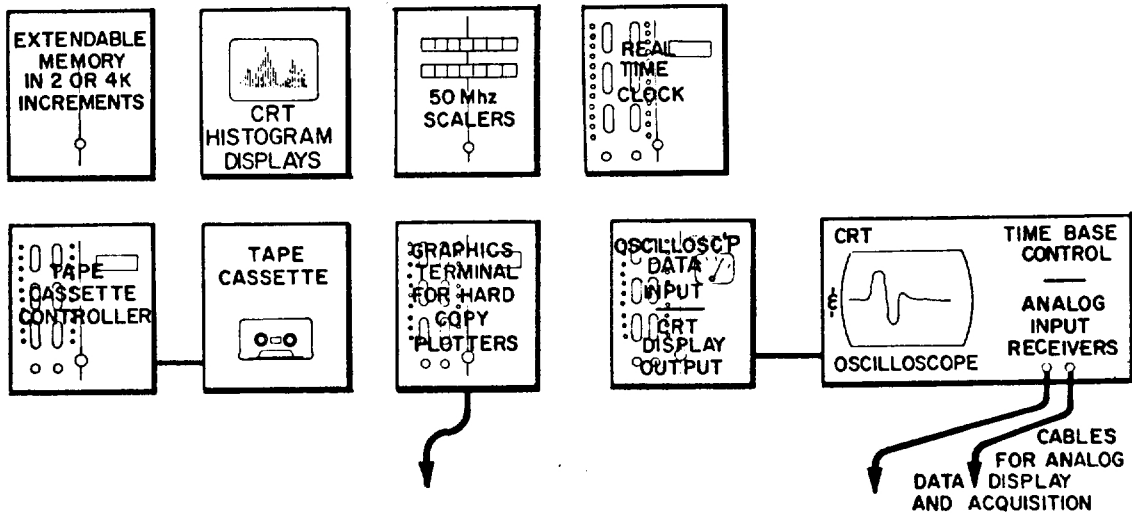

Figure 2

Center) as have other students of NASA's general data-handling requirements. They had an advanced modular concept locally termed "Digital Pathways". Together with Professor Schwartz we have started an interdisciplinary, interdepartmental project to develop what we have termed the "HIQ" terminal with three groups of needs in mind, biochemical research, physical research, and clinical laboratory. This is supported jointly by our NASA grant and AF contract AF F 44620 67C 0070.

Figure 2 is a functional diagram of this modular system. The present funds allow the development of a pilot model. These will consist of the PDP-11 and the direct memory access (DMA) design that is basic to most, if not all, the modules. The DMA portion is to be the left half as shown with connectors and indicator lights. Present plans are to built three or four complete module types to connect to the PDP-11 Unibus. This initial unit will be used to improve service on the MS-9 mass spectrometer in the Organic Chemistry laboratories at Stanford.

After this initial experience it is hoped to build additional of the functional modules and construct an uncommitted system for experimental use. It will be a new type of instrument in that it will bring the computer to the test and research environment as a tool and not a project in itself.

As part of this pilot development we expect to be able to estimate the production cost of such terminals. We believe that they will prove to be economically practicable.

## IX. Cell Separation

While this work was initiated by the subject grant most of the support is now coming from NIH grant (NIH GM 17367) and NIH contract (NIH 69 2064). The work has obvious applications in the medical field.

### A. High Speed Fluorescent Cell Sorter

This unit is designed to measure the fluorescence of cells in a jet of liquid, break up the jet into uniform drops and collect the drops in a series of containers, with all drops containing cells with similar fluorescent characteristics collected in the same container. Tests showing that the system could enrich for plaque forming cells, using the Jerne plaquing technique have been reported in Science. A second unit using a sheath flow system, which encloses the stream of fluid containing the cells in a larger stream of inert liquid has been built and tested. This unit possesses superior optical properties and appears to be more sensitive than the original. A blue laser, now on order, should increase the sensitivity even further.

### B. High Speed Volumetric Cell Sorter

This unit measures the volume of cells by determining the change in electrical resistance in a small orifice containing flowing conducting liquid as the essentially nonconducting cells pass

through. The sheath flow principle has also been applied to this instrument. Downstream of the orifice a jet can be formed and deflected in the same fashion as in the fluorescent sorter.

Measurement of the volume distribution of red blood cells in this instrument indicates that sheath flow gives a more accurate reproduction of the expected approximately Gaussian volume distribution than measurements where the entire orifice is available to the cells. This is indicated in Figure 3 where curve A shows the red cell volume distribution in sheath flow, compared to curve B showing a run using the same orifice when the outer sheath is no longer flowing. Curve C shows the response to the same blood sample of a commercial instrument for measuring red cell volume which uses an orifice without sheath flow. Turbulence effects and non-uniform electric fields close to the orifice sides and faces are probably responsible for the inaccuracies in volume found when sheath flow is not used.

Figure 4 shows a blood sample from a patient with unusually small red cells, who had received massive transfusions of normal cells. The double peak is clearly evident.

This type of instrument should have many applications in a clinical laboratory.

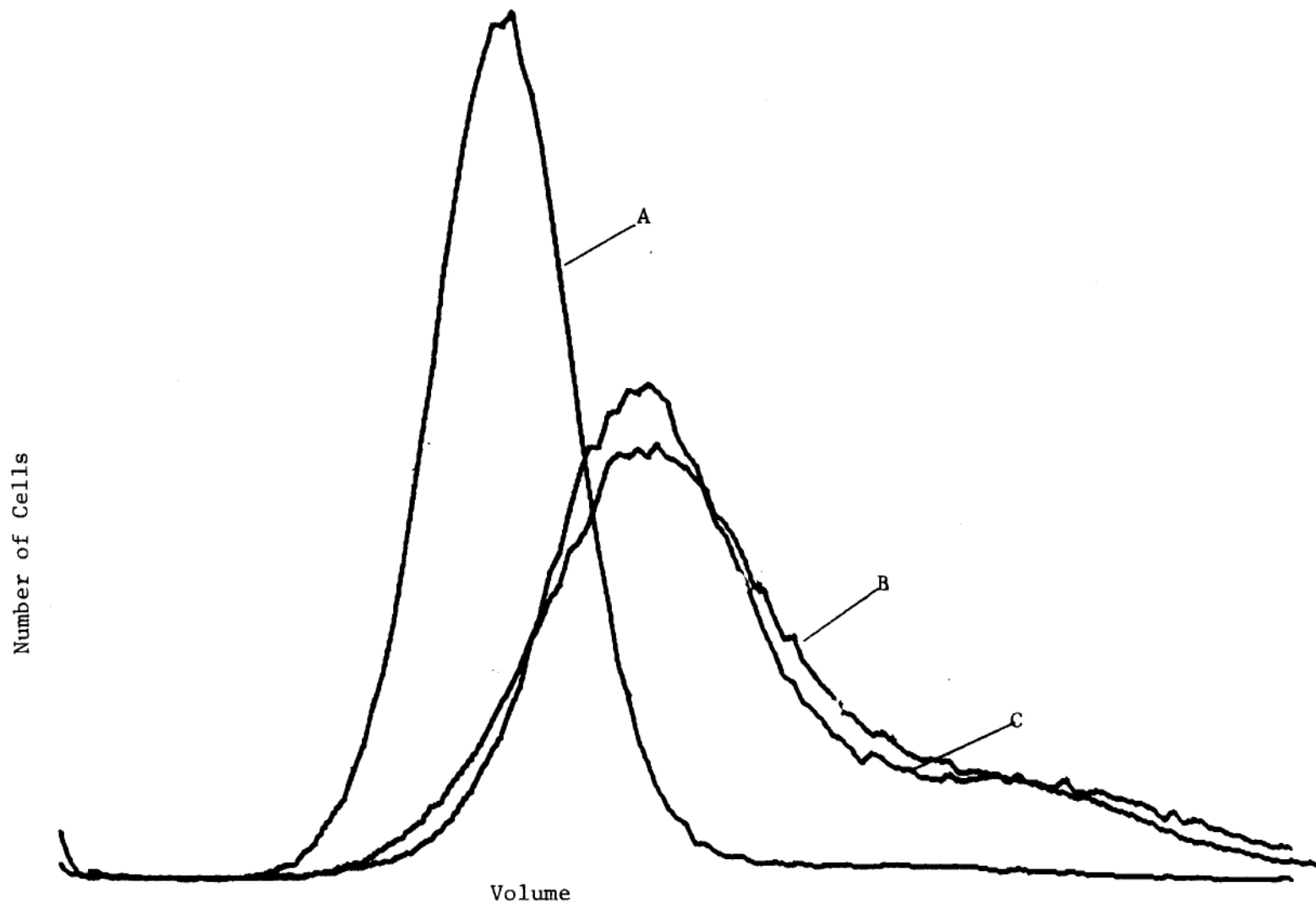

Figure 3 Volume Distribution of Red Cell sample measured in different ways.



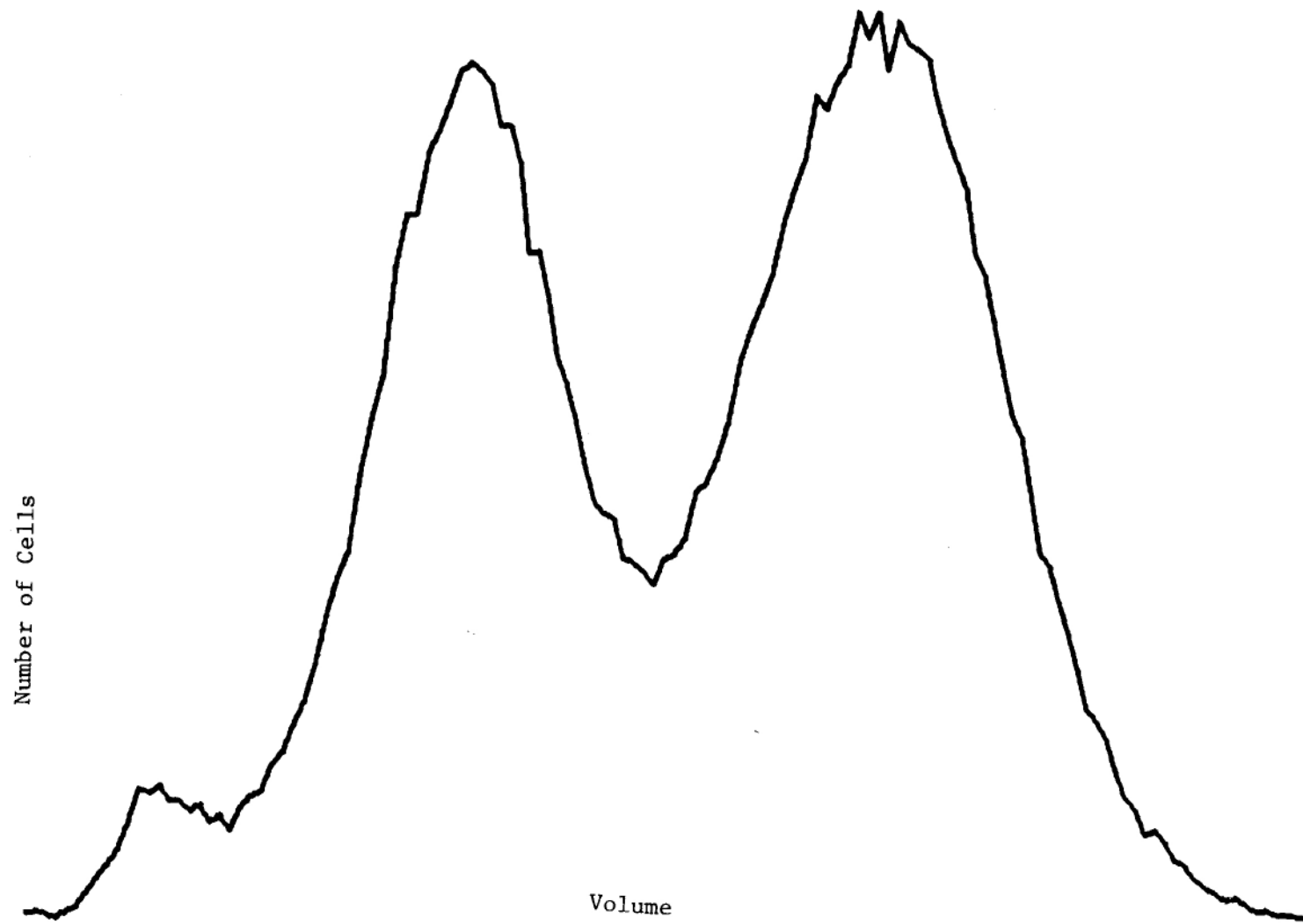

Figure 4 Volume distribution of an abnormal Red Cell sample.

C. Use of fluorescent techniques to test immunological compatibility.

Work has continued on an automated version of the fluorochromatic histocompatibility test. The pickup unit has worked satisfactorily in conjunction with the optical and photoelectric section of our IBM rapid cell spectrophotometer. Presently we are completing a separate optical and photoelectric assembly so that the instrument can work as a self-contained unit. This has been supported by NIH Contract #GM17367.

## X. Optical Data Processing

One of the objectives of the NASA program for the exploration of Mars is to obtain detailed images of the planet from cameras mounted on fly-by, orbiter, and lander spacecraft. Imagery data, upon being telemetered back to Earth, is fed into a high-speed computer for data manipulation and picture generation. Some of the restoration operations required to yield pictures of high quality require large amounts of computer time. As the realtime demands of future missions can impose a heavy burden on available computer capacity, we have performed experiments to investigate the utility of analogue optical data processing procedures to supplement the picture processing capability of the computer.

The equipment assembled for this work is illustrated schematically in Figure 5. Highly directed monochromatic light from a 1 milliwatt continuous wave helium-neon laser is directed through a shutter  $S$  to a microscope objective lens  $L_1$ . A pinhole aperture  $P$ , located at the focal point of  $L_1$ , serves to exclude stray radiation from the primary beam which passes through the hole to a collimating lens  $L_2$ . The light proceeds through two succeeding lens  $L_3$  and  $L_4$ , assumed here each to have focal length  $f$  and to be separated from one another by a distance  $2f$ . It follows directly that if a phototransparency is inserted at  $O$ , a distance  $f$  in front of  $L_3$ , then an image of the transparency will be formed at  $I$ , a distance  $f$  behind  $L_4$ . The radiation pattern in

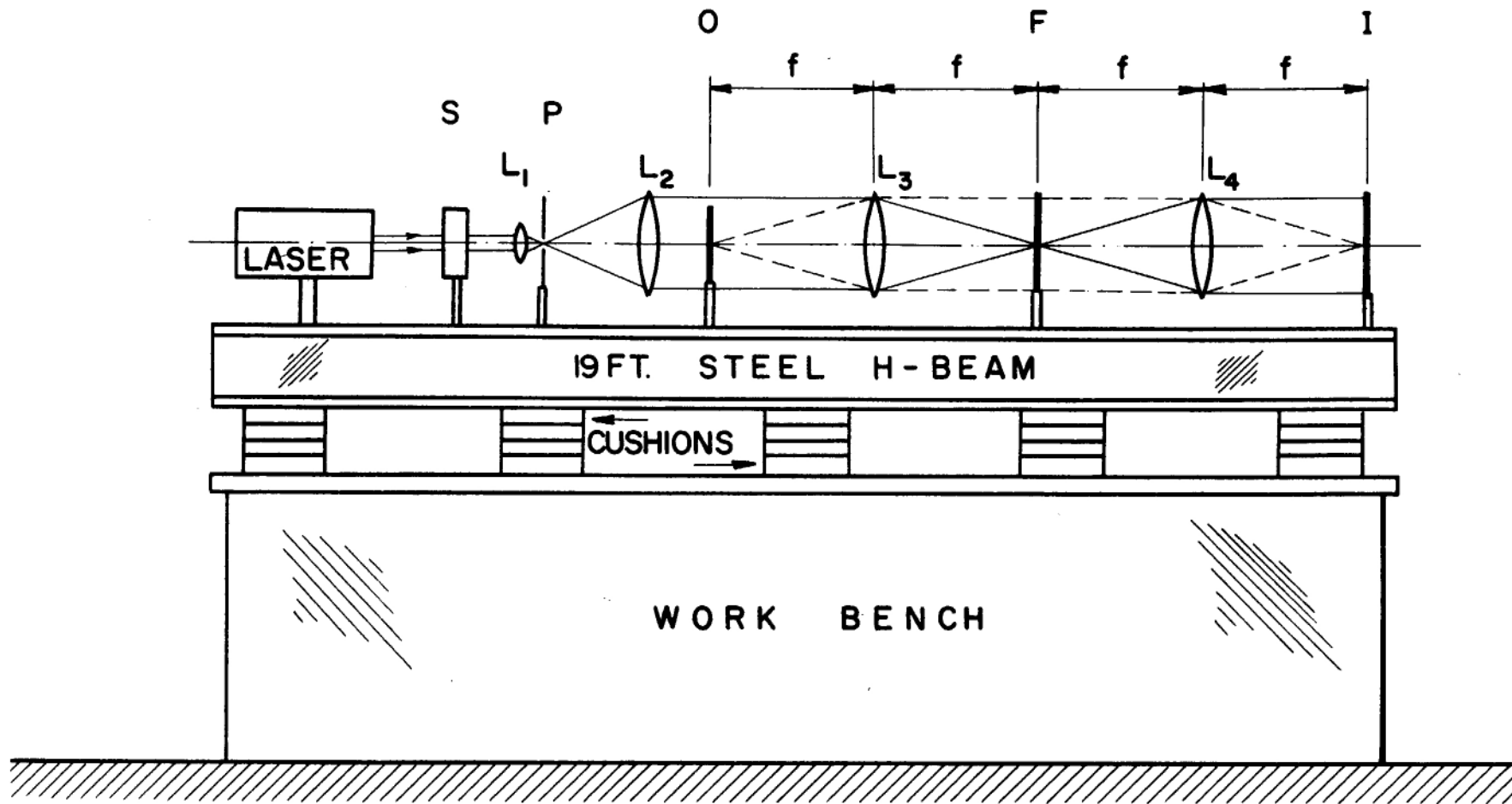
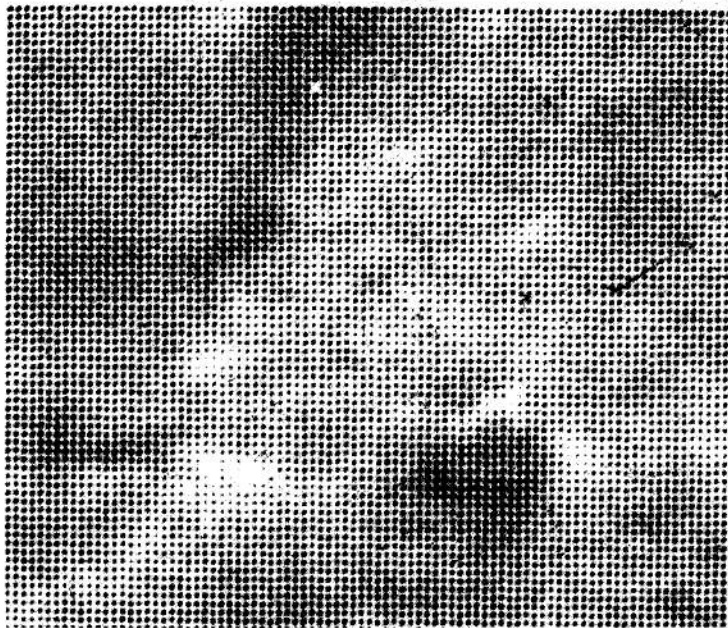
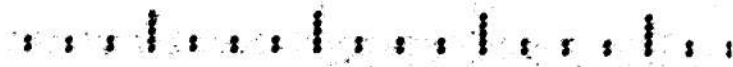
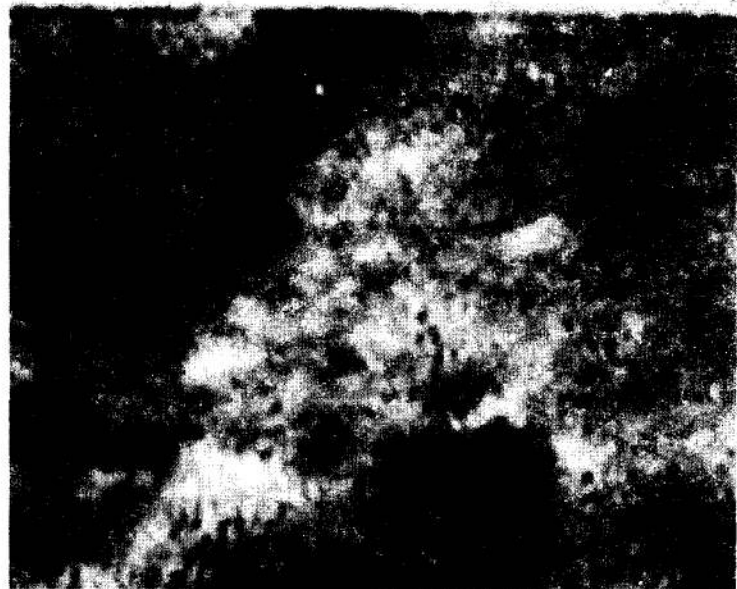

Fig.5 OPTICAL DATA PROCESSING SYSTEM



(a)

Input Transparency placed at 0.



(b)

Output recorded at 1.

Fig. 6 A portion of an image of Mars obtained in the course of the 1964 Fly-by Mission.

the plane F located half way between  $L_3$  and  $L_4$  is of an especially interesting character for our purposes. There appears in this plane a two dimensional Fourier transform of the spatially variable transmissivity of the photo-transparency placed at 0. The operational significance of this is that a variety of useful transformations of the image appearing at I can be accomplished by placing masks of suitable configuration in the plane F.

The application of the above system is then as follows: A phototransparency representing a minimally processed computer generated image of Mars is inserted at 0. A mask designed to accomplish the desired transformation of the image is placed at F, and a photo sensitive recording surface --Polaroid film in our work-- is placed at I. The desired exposure is achieved with the shutter.

Without elaborating on either the details of the radiation pattern appearing at F or the selection of an appropriate mask, we illustrate two examples of operations that can be readily performed.

Figure 6a shows an enlarged portion of an image of Mars obtained from the 1964 Mariner 4 fly-by mission. the full image format consists of an array of 200 by 200 distinct image points, each of an intensity related to the amount of light recorded in the



(a)

Input Transparency placed at 0.



(b)

Output recorded at I.

Fig. 7 An image of Mars recorded during the 1969 Mariner 6 Fly-by mission.

vicinity of the point. The overall effect is that of a half-tone print such as is found in newspaper reproductions of photographs. Normally the computer display operator would partially defocus the image output tube to blend the individual dots to a somewhat greater extent than shown here. In our demonstration we accomplished a quite full blending by inserting an appropriate mask at F. The output image recorded at I is illustrated in Figure 6b.

Two features of Figure 6b bear comment. Firstly, the slightly mottled character in the image results principally from the fact that our mask was formed by cutting a sharply rounded hole in our opaque sheet. This affect can be alleviated by utilization of a "soft" edged mask. Secondly, imperfections in the input film are exaggerated as indicated, for instance, by the small black dots beneath and about the dark area to the lower right of center.

Our second example, illustrated in Figure 7, involves an image recorded during the 1969 Mariner 6 fly-by mission. The minimally processed computer image shown in Figure 7a exhibits a form of artifact common to the series, namely, harmonic "noise" manifesting itself in this instance by some ten bands of interference spread across the picture. The result of our effort to suppress these bands by use of an appropriate F-plane mask is shown in Figure 7b.



More sophisticated operations, of a pattern recognition type, can be performed. We have not attempted these, nor do we believe it likely that they can be developed in time to compete with digital processing for MM 1971.

## XI. Quasi-Microscope for Viking Mars Lander

The maximum spatial resolution capability of the facsimile camera system proposed for the Mars Viking 1975 Lander is 1 mm. at a minimum object range of 2 meter. Mission constraints for this first Lander preclude the inclusion of a self-contained microscope package. However, as there is great interest in the acquisition of microscopic data, we have given some thought to the utilization of the proposed camera in a higher resolution mode.

System reliability requirements preclude the addition of any camera options that could in the event of malfunction of the deployment system jeopardize the normal panoramic capability of the system.

The simple observation that a magnifying eyepiece placed approximately one focal length from an object but arbitrarily far from the eye can provide substantial magnification, suggests a possible approach. A remote auxiliary lens would enable the camera to survey a smaller portion of its field in a quasi-microscope mode.

We have studied both theoretically and experimentally the features of such a system. We find for the proposed camera, for

example that a complementary F/1 auxiliary lens of 40 mm diameter placed at a range of 2 meter would enable acquisition of an unvignetted image composed of 490 resolution elements at a spatial resolution of 0.025 mm. - representing a 40-fold lateral magnification relative to the unenhanced system.

General system equations have been derived and depth-of-field relations have been established. We have examined an incidental wide angle capability of the auxiliary lens that offers the option of quick scanning and/or monitoring over large angles and areas.

It may be of more than academic interest to note a facsimile microscope, patterned after the principle of the camera, can be an extremely small device. An F/1 system consisting of a single lens of arbitrarily small size and a pinhole focal plane aperture can resolve down to one wavelength of light.

## XII. Mariner Mars 1971 Orbiter Photography

A system is being developed to manipulate digitized photographs of Mars utilizing a time shared computer. The user is able to interact with the system via a CRT display screen and a typewriter keyboard. The system operates on a PDP-10 computer with 128,000 thirty-six bit words of core storage which is augmented by a 20 million word disk system. The project is directed toward increasing the speed and sensitivity with which judgments can be made about features on the surface of Mars with special emphasis on real time variation.

The user is able to select a region which is common to a pair of images and request that the respective portions of the two images be projected to a common point of view. Suitable geometric and photometric transformations then generate two new images in which common features are aligned to within the accuracy of the spacecraft position and orientation data. Techniques also exist for improving the alignment of the two transformed images to within a fraction of a kilometer on the surface of Mars for the 1969 near-encounter photographs. After proper alignment, the two images can be analyzed to detect significant differences in the two images of the same area. This technique is considered fundamental to any significant variable features study.

The capability also exists to analyze the outlines of features which are characterized by intensity differences in the image. These features may be craters, polar caps, sinuses or other features of Mars. Work is also being done in recognizing, classifying and measuring these features.

XIII. REPORTS, PUBLICATIONS AND PAPERS

July 1, 1969 - July 1, 1970

PUBLICATIONS

1. G.W. Hodgson, E. Peterson, K.A. Kvenvolden, E. Bunnenberg, B. Halpern, C. Ponnampereuma, "Search for Porphyrins in Lunar Dust Returned from Apollo 11, Science **167**, 763 (1970).
2. C. Ponnampereuma, K. Kvenvolden, S. Chang, R. Johnson, G. Pollock, D. Philpott, I. Kaplan, J. Smith, J.W. Schopf, C. Gehrke, G. Hodgson, I.A. Breger, B. Halpern, A. Duffield, K. Krauskopf, E. Barghoorn, H. Holland, K. Keil, "Search for Organic Compounds in the Lunar Dust from the Sea of Tranquillity, Science **167**, 760 (1970).
3. B. Halpern, G.W. Hodgson, E. Bunnenberg, E. Peterson, K. Kvenvolden, C. Ponnampereuma, "Search for Organic Matter on the Moon," Geochemica et Cosmochimica Acta (in press, 1970).
4. W. Pereira, V.A. Bacon, W. Patton and G.E. Pollock, B. Halpern, "The Use of Phenylethylisocyanate in the Optical Analysis of Asymmetric Secondary Alcohols by G.L.C., Anal. Let **3**, 23 (1970).
5. I.S. Forrest, L.G. Brooks, S.D. Rose, B. Halpern, V.A. Bacon, and J. Silberg, "Fluorescent Labelling of Psychoactive Drugs, Agressologie (in press, 1970).
6. W. Pereira, V. Close, W. Patton, and B. Halpern, "Transesterification with an Anion-Exchange Resin, Jour. Org. Chem. **34**, 2032 (1969).
7. W. Pereira, V.A. Close, E. Jellum, W. Patton and B. Halpern, "Alcoholysis of the Merrifield-Type Peptide-Polymer Bond with an Anion Exchange Resin," Aust. J. Chem. **22**, 1377-40 (1969).
8. B. Halpern, "Optical Activity" for "Exobiology and the Exploration of Mars," Applied Optics **8**, 1349 (1969).
9. B. Halpern, W. Patton and P. Crabbe, "Cotton Effect of Some Derivatives of Amino Acids and Amino Alcohols," J. Chem. Soc. B, 1143 (1969).
10. E. Jellum, V.A. Close, W. Patton, W. Pereira, and B. Halpern, "A Gas-Liquid Chromatographic Method for the Determination of Phenylalanine in Serum," Anal. Biochem. **31**, 227 (1969).

11. V. Bacon, E. Jellum, W. Patton, W. Pereira, and B. Halpern, "Peptide Sequencing by Low Resolution Mass Spectrometry I. The Use of Acetylacetyl Derivatives to Identify N-Terminal Residues," Biochem. and Biophys. Res. Comm. 37, No. 6, 1969.
12. E. Jellum, V.A. Bacon, W. Patton, W. Pereira, Jr., and B. Halpern, "Quantitative Determination of Biologically Important Thiols and Disulfides by Gas-Liquid Chromatography," Anal. Biochem. 31, 339-347 (1969).
13. W. Patton, E. Jellum, D. Nitecki, W. Pereira and B. Halpern, "The Modification of Phenylalanine Containing Cyclo-Peptides with Nitrosyl Chloride," Aust. J. Chem. 22, 2709 (1969).
14. D.P.L. Sachs, E. Jellum and B. Halpern, "Determination of the Stereospecific Hydrolytic Action of Peptsin by Nuclear Magnetic Resonance Spectroscopy," Biochim. Biophys. Acta 198, 88 (1970).
15. S. Liebes, Jr., "Brightness - On the Ray Invariance of  $B/n^2$ ," Am. Jour. Phys. 37(9), 932 (1969).
16. H.R. Hulett, W.A. Bonner, J. Barrett, L.A. Herzenberg, "Cell Sorting: Automated Separation of Mammalian Cells as a Function of Intracellular Fluorescence," Science 166, 747 (1969).
17. S. Liebes, Jr., "Gravitational Lens Simulator," Am. J. Physics 37, 103 (1969).
18. H.R. Hulett, L.A. Herzenberg, W.A. Bonner, P.L. Wolf, "Rapid Cell Sorter - A New Tool for Cell Study with Clinical Applications," Laboratory Investigations (in press). To be presented at the 59th Annual Meeting of the International Academy of Pathology, Mar. 10-14, 1970, St. Louis, Mo.
19. B. Halpern, W.E. Pereira, M.D. Solomon, E. Steed. Submitted to Anal. Biochem. (1970).
20. B. Halpern, G.E. Pollock, "The Configuration of the Ollisoleucine present in 'Maple Syrup urine disease' Plasma". Submitted to Anal. Biochem. (1970).
21. J. Cymerman Craig, W.E. Pereira, B. Halpern and J.W. Westley. "Optical Rotatory Dispersion and Absolute Configuration XVII.  $\alpha$ -Alkylphenyl acetic acids. Submitted to Tetrahedron (1970).

22. W. E. Pereira, M. Solomon, B. Halpern, "The Use of (+) 1-Phenyl-2,2,2,-Trifluoroethyl-hydrazine in the Optical Analysis of Asymmetric Ketones by GLC". Submitted to J. Org. Chem. (1970).
23. W.E. Pereira, B. Halpern, M.D. Solomon, A. M. Duffield, "Electron Impact Promoted Fragmentation of Alkyl-N-(1-Phenylethyl)-carbanates". Submitted to Org. Mass. Spectrom., (1970).
24. H.R. Hulett, "Non-enzymatic Hydrolysis of Adenosine Phosphates". Nature 225, No.5239:1248-1249 (1970).
25. W.E. Reynolds, V.A. Bacon, J.C. Bridges, T.C. Coburn, B. Halpern, J. Lederberg, E.C. Levinthal and E. Steed, R.B. Tucker, "A Computer Operated Mass Spectrometer System", Anal. Chem. (submitted, 1970).
26. W. E. Reynolds, "Instrumentation in a Time-Shared Environment", Research/Development 21(4):20-26 (1970).
27. Lederberg, J., 1969. Mars through a crystal ball. Applied Optics 8:1269-1270.
28. Schroll, Gustav, A. M. Duffield, Carl Djerassi, B.G. Buchanan, G.L. Sutherland, E.A. Feigenbaum and J. Lederberg, 1969. Applications of artificial intelligence for chemical inference. III. Aliphatic ethers diagnosed by their low resolution mass spectra and NMR data. J. Am. Chem. Soc. 91:7440.
29. Lederberg, J. Exobiology: search for evidence of life or of biological habitats. Icarus (in press)
30. Lederberg, J., G.L. Sutherland, B.G. Buchanan and E.A. Feigenbaum, 1969. A heuristic program for solving a scientific inference problem: summary of motivation and implementation. Stanford Artificial Intelligence Memo AIM-104.
31. A. Buchs, A.M. Duffield, G. Schroll, C. Djerassi, A.B. Delfino, B.G. Buchanan, G.L. Sutherland, E.A. Feigenbaum, and J. Lederberg, "Applications of Artificial Intelligence for Chemical Inference IV. Saturated Amines Diagnosed by Their Low Resolution Mass Spectra and Nuclear Magnetic Resonance Spectra", 1970 (in press).
32. Y.M. Sheikh, A. Buchs, A.B. Delfino, G. Schroll, A.M. Duffield, C. Djerassi, B.G. Buchanan, G.L. Sutherland, E.A. Feigenbaum and J. Lederberg, "Applications of Artificial Intelligence for Chemical Inference V. An



Approach to the Computer Generation of Cyclic Structures. Differentiation Between All the Possible Isomeric Ketones of Composition C<sub>6</sub>H<sub>10</sub>O", Organic Mass Spectrometry, 1970 (in press).

33. A. Buchs, A.B. Delfino, A.M. Duffield, C. Djerassi, B.G. Buchanan, E.A. Feigenbaum and J. Lederberg, "Applications of Artificial Intelligence for Chemical Inference VI. Approach to a General Method of Interpreting Low Resolution Mass Spectra with a Computer", Chem. Acta Helvetica, 1970 (in press).
34. G. Schroll, A.M. Duffield, Carl Djerassi, B.G. Buchanan, G.L. Sutherland, E.A. Geigenbaum, and J. Lederberg, "Applications of Artificial Intelligence for Chemical Inference. III. Aliphatic Ethers Diagnosed by Their Low-Resolution Mass Spectra and Nuclear Magnetic Resonance Data", J. Am. Chem. Soc. 91:7440 (1969).