

Technical Report No. IRL 1105

**CYTOCHEMICAL STUDIES OF PLANETARY MICROORGANISMS
EXPLORATIONS IN EXOBIOLOGY**

29/10/69
Status Report Covering Period July 1, 1969 to January 1, 1970
For
National Aeronautics and Space Administration
Grant NGR-05-020-004



Instrumentation Research Laboratory, Department of Genetics
Stanford University School of Medicine
Stanford, California 94305

Report to the National Aeronautics and Space Administration
"Cytochemical Studies of Planetary Microorganisms - Explorations in Exobiology"

NGR-05-020-004

Summary Report Covering Period July 1, 1969 to January 1, 1970

Instrumentation Research Laboratory, Department of Genetics
Stanford University School of Medicine
Stanford, California

Joshua Lederberg
Principal Investigator

Elliott C. Levinthal, Director
Instrumentation Research Laboratory

A. INTRODUCTION

This status report covers the activities of the Instrumentation Research Laboratory during the two quarter period from July 1, 1969 to January 1, 1970.

While the main support of the IRL activities during this period continued to be the NASA grant NGR-05-020-004, some of the funds have come from other grants, other agencies, and in some cases private institutions. This report includes all the activities of the laboratory which relate to or have benefited from NASA support regardless of whether or not they have received direct support by this NASA grant.

We have sought support for our work from other agencies, particularly the National Institutes of Health. We have had some degree of success, especially in the area of cell separation. Effective January 1, 1970 essentially all of our work in this area will be supported by NIH grants or contracts, GM 17367 and NIH 69-2064. We have received some support for Dr. Halpern's work under NIH Grant AM 12797-01 and are seeking additional support for his work on the interaction of chlorine compounds with DNA.

These interrelationships benefit our NASA program in two ways. It aids the rapid utilization for medicine and biology in general of the ideas and skills developed because of our interests in space missions. It not only provides us with the opportunity of testing instrumentation methods, applicable to future NASA programs, in circumstances of solving current scientific problems but also provides much needed additional support. This support hopefully will permit the Instrumentation Research Laboratory to continue to function with sufficient technological depth and breadth to allow responses to future NASA needs.

For these reasons we have felt it desirable to carry out some laboratory work that could lead to new fruitful relationships. A meeting on Space Bioscience - Technology Utilization held on November 28-30, 1969 under the auspices of the Interdisciplinary Communication Program, was attended by Professor Lederberg and Dr. Levinthal. This meeting reinforced our conviction that there are areas of environmental health that both make use of our scientific and technological skills and serve our future possible interests. During this reporting period we have expended some efforts investigating possibilities involving environmental health in general and environmental health monitoring in particular.

The general areas of the program resume, Part B of the report, are:

- I. Optical Resolution by Gas Liquid Chromatography
- II. Gas Chromatography of Amino Acids
- III. Chlorine Reactions with DNA Compounds
- IV. Apollo 11 Sample Analysis
- V. Analysis of Natural Products by Mass Spectrometry
- VI. DENDRAL
- VII. Computer Aided Research Instrumentation
- VIII. Cell Separation
- IX. Optical Data Processing
- X. Quasi-Microscope
- XI. Other Mission Activities
- XII. Environmental Perspective
- XIII. Reports, Publications and Papers

B. PROGRAM RESUME

I. Optical Resolution by Gas Liquid Chromatography

In continuation of our work on the g.l.c. separation of the D and L antipodes of organic molecules via diastereoisomer formation, we have applied this technique to the resolution of secondary alcohols,(4) cyclic ketones, and phenoxypropionic acids. Since the order of elution of the diastereoisomers from a g.l.c. column is dependent on conformational influences the absolute configuration of the alcohols, ketones and phenoxypropionic acids could also be established. The above technique has also been applied successfully to determine the absolute configuration of the allo-isoleucine which is present in the serum of patients suffering from "Maple Syrup" disease.

II. Gas Chromatography of Amino Acids

Established methods for the g.l.c. analysis of amino acids involve time consuming chemical manipulations to convert the amino acids into volatile derivatives suitable for g.l.c. By using the injector port of the gas chromatograph as a chemical reactor we have now succeeded in converting the amino acids into volatile derivatives in situ. Since this conversion was concentration dependent, the injector port of a conventional gas chromatograph had to be modified to permit the removal of the solvent, before the introduction of the sample into the heated zone of the injection system. The simplicity of this process should facilitate the whole operation.

III. Chlorine Reactions With DNA Compounds

Chlorine plays an indispensable role in the purification of our water supplies and urban settlement would be imperiled without chlorination or some equivalent means of removing polluting bacteria from water. Despite our great dependence on the chlorine disinfection of water, little is known about the mechanism by which chlorine kills bacteria. It has been assumed that the toxic effect of "active chlorine" is exerted through its reaction with cell membranes which are being destroyed in the process, but since hypochlorite will also inactivate certain viruses, other mechanisms must also be involved. The scanty published data suggests that the most likely route involves an attack of chlorine on the DNA of the microbe. This is supported by the isolation of appreciable quantities of chlorinated cytosine and uracil after hypochlorite treatment of Escherichia coli or tobacco mosaic virus and the loss of infectivity of the virus subsequent to such treatment. Additional evidence is also furnished by the mutagenic action of 5-halo-uracil, when it is incorporated into the DNA of bacteriophage T₂. Nevertheless chronic toxicity to man from chlorine has not been considered a hazard because the chlorinating agent is known to react rapidly with organics and the reagent is supposed to be destroyed in the body fluids. This conclusion however ignores the possibility that the chlorine may react with a variety of nitrogen containing compounds to form chloramines, which may themselves form potent chlorinating agents. Although the bactericidal potency of known chloramines is considerably less than hypochlorite itself, it is precisely the less reactive forms of chlorine that makes these agents potentially the most insidious. Whilst there is an extensive literature on the stable end products of halogenation of the biologically important purine and pyrimidine bases and their nucleosides and nucleotide derivatives, no serious attempt has been made to look for, or characterize any of the labile chloramine intermediates which may be present in these reaction mixtures. This is somewhat surprising, as the chemistry of structurally related nitrogen

heterocyclics suggests that fairly stable chloramine derivatives may be formed.

In some preliminary experiments, we have been able to show, that the action of sodium hypochlorite on the biologically interesting bases, at a physiological pH, leads to chlorine containing derivatives which behave as typical chloramines. These compounds give a positive color test with tolidine (Von Arx-Neher) and liberate iodine from KI solution. The latter reaction can be used to quantitatively estimate the amount of labile chlorine present in the reaction mixtures. In the case of cytosine, a crystalline chlorinated intermediate could be isolated. The microanalytical data and the mass spectrum (molecular ion isotope signature) show the presence of 2 chlorine atoms in the product. Titration of the analytical sample shows the presence of one labile chlorine. The other, inactive chlorine atom has been shown to be bonded to carbon in the 5 position. Under essentially the same experimental conditions DNA (from calf thymus - highly polymerized) can be chlorinated and the product can be passed through Sephadex (G25-coarse) to remove traces of degradation products. The fractions containing the modified DNA (approximately same molecular weight as the original DNA) gave a positive test with tolidine and liberated iodine from potassium iodide solution.

Our preliminary work suggests that a study of the chemistry of the chloramine reaction products of the bases and their nucleoside and nucleotide derivatives will provide evidence regarding the nature of the chemical changes which occur in the DNA macromolecule.

IV. Apollo 11 Sample Analysis

Under Grant NAS 9-9439 we have examined the carbon compounds present in two samples of Apollo 11 for porphyrin-like pigments. Our results indicated that lunar fines contain "porphyrin-like pigments" as indicated by fluorescence spectrometry and analytical demetallation. Major fluorescence excitation at 390 nm was obtained for 600-690 nm emission. The abundance of porphyrin-like material was estimated to be about 10^{-4} $\mu\text{g/g}$. Similar pigments were found in exhaust products from a lunar descent engine. Although the infall of meteoritic dust to the lunar surface is appreciable and may be expected to contain considerable carbon and associated organic compounds including porphyrins, the data suggest that most, if not all, of the indicated porphyrin aggregate of the lunar samples was probably introduced during landing of the lunar module.

V. Analysis of Natural products by Mass Spectrometry

During the past year research has continued on the structural analysis by mass spectrometry of natural products isolated from plant, animal and marine sources. A list of publications resulting from this experimentation follows:

"Mass Spectrometry in Structural and Stereochemical Problems - CLXXII: The Electron-Impact Promoted Fragmentation of 1,2-Cyclohexanediol" by M. Karen Strong and Carl Djerassi. Org. Mass Spectrometry 2, 631 (1969).

"Application of Ion Cyclotron Resonance to the Structure Elucidation of the $C_3H_6O^+$ Ion Formed in the Double McLafferty Rearrangement" by George Eadon, John Diekman, Carl Djerassi. J. Am. Chem. Soc. 91, 3986 (1969).

"Mass Spectrometry in Structural and Stereochemical Problems CLXXVI. The Course of the Electron Impact Induced Fragmentation of Androstane" by L. Tokes and Carl Djerassi. J. Am. Chem. Soc. 91, 5017 (1969).

"Mass Spectrometry in Structural and Stereochemical Problems - CLXXVIII. The Electron-Impact Promoted Fragmentation of 1,2-Cyclohexene Oxide" by M. K. Strong, P. Brown, C. Djerassi. Org. Mass Spectrometry 2, 1201 (1969).

"Mass Spectrometry in Structural and Stereochemical Problems. CLXXIX. The Electron Impact Induced Rearrangements of I-Phenylheptenes. Further Evidence for Double Bond Lability" by A. F. Gerrard and C. Djerassi. J. Am. Chem. Soc. 91, 6808 (1969).

"Mass Spectrometry in Structural and Stereochemical Problems. CLXXXIII. A Study of the Electron Impact Induced Fragmentation of Aliphatic Aldehydes" by R. J. Liedtke and C. Djerassi. J. Am. Chem. Soc. 91, 6814 (1969).

VI. Dendral

Further work on this related project has concentrated on the application of Artificial Intelligence to the analysis of specific classes of organic molecules.

Ref. "Applications of Artificial Intelligence for Chemical Inference. III. Aliphatic Ethers Diagnosed by Their Low-Resolution Mass Spectra and Nuclear Magnetic Resonance Data" by G. Schroll, A. M. Duffield, Carl Djerassi, B. G. Buchanan, G.L. Sutherland, E. A. Feigenbaum, and J. Lederberg. J. Am. Chem. Soc. 91, 7440 (1969).

VII. Computer Aided Research Instrumentation

Three principal areas of effort this period were: 1) Continuing use of and improvements of the ACME time-shared computer for instrumentation, primarily with the double focus high resolution and quadrupole mass spectrometer, 2) Support of the current cell separator project described in the section VIII, and 3) Instrumentation for the Apollo 11 Sample Analysis described in section IV.

The first two items represent continuing use of the ACME-LINC instrumented components described in previous status reports. ACME use is now in a mature state of development. Our experiences with this instrumentation computer and such continuing work as the mass spectrometers mentioned, now give us a sound basis for a review of the ACME computer instrumentation experiment. Prima facie evidence is that it is useful and that it has demonstrated the feasibility of time-shared computers for laboratory instrumentation. This experience will enable us to incorporate improvements into a still more powerful laboratory computer terminal.

The accomplishments to date have been the source of considerable external interest. The work has been reported in papers given at a number of technical society conferences on mass spectroscopy, chemistry, and computers. A rather continuous flow of visitors, representing perhaps 20 to 30 institutions per year, are shown the mass spectrometers and computer systems. There have been three invited communications in this last reporting period: One request was for an article to appear in April 1970, RESEARCH/DEVELOPMENT; a request for a contribution for a forthcoming text edited by Professor Waller, Oklahoma State, and an invited paper to the 1970 Pacific Conference on Chemistry and Spectroscopy, San Francisco.

A commercial version of our GLC-MS computer control interface is produced by Systems Industries, Sunnyvale, California.

The instrumentation for the Apollo 11 porphyrin analysis using magnetic circular dichroism (MCD) involved the development of two unique features of computer instrumentation which are described here. The instrument itself, a magnetic circular dichrometer, for the purposes of this description may be assumed to have the signal attributes of a motor driven scanning spectrophotometer. (Actually it is far more complex with circular polarized modulating facilities, supercooled magnets, etc.) The output is detected by a photomultiplier. A commercial phase-locked amplifier is used for electronic signal detection.

The computer system function for both control and data acquisition. The wavelength scan drive motor was replaced with a stepping motor to give the computer digital control of the wavelength to be sampled.

Two unique features were used at the data acquisition interface. First, the use of a stepping motor permitted a full integrator in the signal path to improve signal to noise. With the computer control, there was fast instrument changes in wavelength between observations and a statistically stationary signal during observations. The integrator channel has the minimum bandwidth commensurate with the sampling time. The second feature is designed to optimize the information rate vs acquisition time. The integration time of the signal integrator is chosen to be inversely proportional to time. Figure 1 is an abbreviated schematic. Simultaneously with start of signal integration, a time signal (generated as a ramp voltage) is started. The increasing signal at the signal integrator output, (both plus and minus to check for absolute magnitude) and the time signal are monitored by a comparator. When any one of these reaches a predetermined value, V_{ref} , a demand pulse is generated. At that time the computer reads both the integrated signal and time signal.

The sample time, T , and instrument dwell is a maximum for small signals and a minimum for large signals. The computer calculates the signal value by performing the division $S = \int sdt/T$.

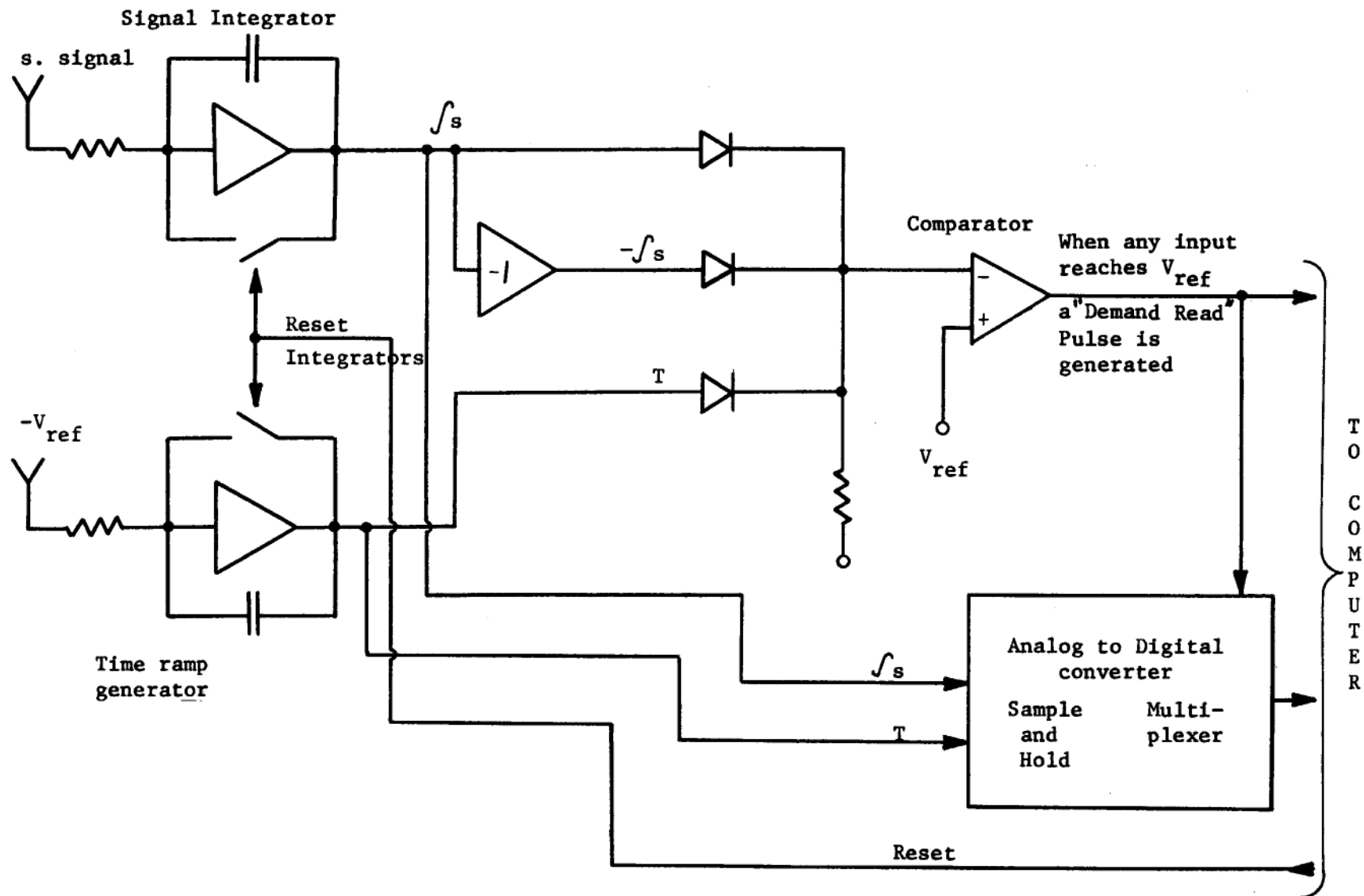

Figure 1. The schematic of the circuit to acquire the signals $\int s dt$ and T . The computer then calculates $S = \int s dt/T$.

Figure 2 is a graphical representation showing the locus of sample points. Note that either, or both, $\int s dt$ or T will always be at the most advantageous portion of the A-to-D range, near full scale.

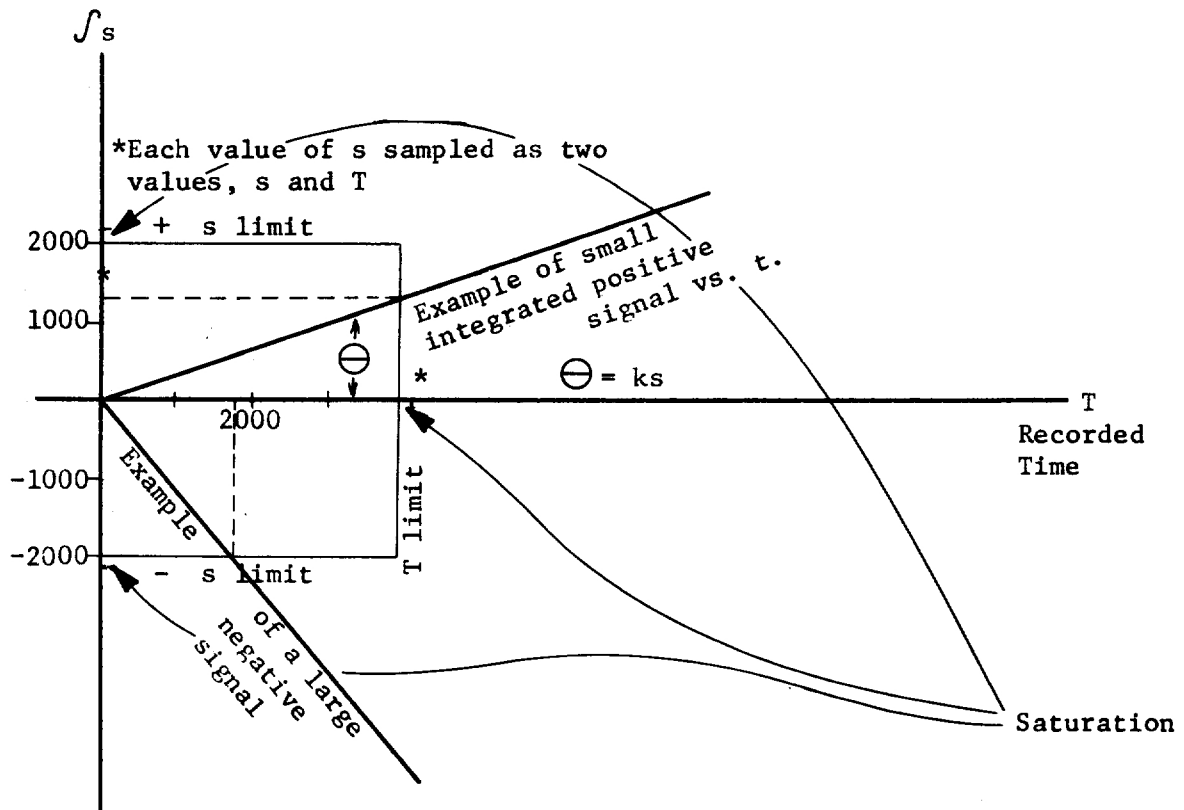

Figure 2. A locus of $\int s$ and T for various levels of signal (S).

VIII. Cell Separation

A. High Speed Fluorescent Cell Sorter

This unit is designed to measure the fluorescence of cells in a jet of liquid, break up the jet into uniform drops and divert those drops containing cells with different fluorescent characteristics into different containers. During the early part of this period, testing continued on separation of fractions enriched in plaque forming cells. The successful results of some of these tests were reported in Science¹. The latter part of the period was devoted to constructing a second improved version of the apparatus, based on the sheath flow system previously described. The interest generated in the application of the cell sorting technique to medical problems, particularly to differential white cell counting, has resulted in the award of a grant from the National Institutes of General Medical Sciences for further work (Grant NIH GM 17367).

B. High Speed Volumetric Cell Sorter

This unit measures the volume of cells by determining the change in electrical resistance in a small orifice containing flowing conducting liquid as the essentially nonconducting cells pass through. Downstream of the orifice a jet is formed and deflected in the same fashion as in the fluorescent cell sorter. The sheath flow system has been applied to this system and the clogging problems previously experienced with sufficient concentrations of protective protein have been overcome.

A series of measurements of volume distribution of red blood cells samples, including some from patients with various sorts of pathological conditions has been begun. It appears that diagnostically valuable

¹ Hulett, H. R., W. A. Bonner, J. Barrett, L. A. Herzenberg. "Cell Sorting: Automated Separation of Mammalian Cells as a Function of Intracellular Fluorescence." Science 166, 747 (1969).

relations between the volume distributions and such conditions as reticulocytosis (where a large percentage of the cells are immature and thus larger than normal) can be made with this instrument.

C. Use of Fluorescent Techniques to Test Immunological Compatibility

As mentioned in the last report we have been working on an NIH contract (NIH 69-2064) to build and test an automated version of the fluorochromatic histocompatibility test, using the technique developed in the cell sorter work. An automated system for picking up and delivering micro samples has been built and is undergoing preliminary testing. In addition semi-automated experiments have shown that the system should be approximately an order of magnitude more sensitive than the presently used manual tests. Such increased sensitivity may be extremely important in testing for possible immunological rejection problems between proposed donors and recipients in organ transplants. A description of this work has been submitted for publication in Transplantation.

IX. Optical Data Processing

We have constructed a simple and flexible optical data processing system with which we have performed experiments directed toward determining the applicability of such a system to the analysis of Mariner Mars 1971 Orbiter imagery data.

The system consists of a 100 milliwatt helium-neon laser, and assorted lenses, holders, apertures, and shutters, mounted on an optical bench fabricated from a nineteen foot section of steel H-beam. We have acquainted ourselves with many of the idiosyncracies of coherent light systems such as sensitivity to film cleanliness and lens imperfections, and we have developed a general familiarity with operational problems exclusive of those associated with matched filter applications.

Our prime interest has been to ascertain the extent to which optical data processing procedures could be called upon to supplement the real time capability to perform digital computer manipulation of the data.

For present purposes, the interesting feature of the coherent optical data processing system is the existence between the input and output image planes of a transverse plane containing the spatial frequency Fourier transform of the spatially variable input plane film transmittance. The system therefore lends itself particularly well to image transformations suited to performance in the Fourier domain.

We have established as our principal finding that if coherent noise such as that characteristic of the Mariner Mars 1969 Fly-By data, is present in 1971, it can be suppressed by performing appropriate masking transformations to the power spectrum in the Fourier plane. It must be appreciated however, that it is not likely that this operation nor any other can be carried out with a cleanliness or a precision matching that of an appropriately programmed digital computer. If, however, the computer capability is saturated by other demands, a degree of coherent noise removal can be achieved.

It is also possible to undertake a modes degree of restoration of modulation transfer function image degradation. The results of such operations are not likely however to significantly enhance the quantitative merit of the images because of the introduction of unavoidable image artifacts intrinsic in practical applications of these techniques.

X. Quasi-Microscope

The proposed Viking Mars 1975 Lander facsimile camera has a spatial resolution capability of ~ 1 mm. at minimum range. We have investigated the possibility of introducing a remote auxiliary lens for the purpose of utilizing the system in a quasi-microscope mode. Remote location (e.g. 100 or 200 cm range) enables the achievement of microscope capability without jeopardizing the panoramic function of the system, such as could result from the malfunction of an auxiliary lens integral to the camera mechanism.

It has been determined, for example, that the placement of a 40 mm diameter F/1 lens at a range of 200 cm. will enable acquisition of an unvignetted image composed of 490 pixels at a spatial resolution of 25 microns. The optics have been studied in some detail and general system equations have been derived. Depth of field relations have been established and an incidental wide angle monitoring and quick scanning capability has been established.

XI. Other NASA Mission Activities

During this period Professor Lederberg and Dr. Levinthal have been directly involved in Mariner Mars 1971 and Viking 1975 mission activities.

Professor Lederberg is a principal investigator on the MM '71 Television Team and Chairman of the Exobiology Discipline Group of that team. Dr. Levinthal is co-investigator on the team and a member of the Exobiology Discipline Group. He has served on the Hardware Task Group and is now chairman of the Data Processing Task Group and a member of the Mission Operations Planning Group.

Professor Lederberg has been a consultant to the Biology Instrument Team and is an investigator on the Biology Science Team for the Viking '75 mission. Dr. Levinthal served on the Imaging Instrument Team and is an investigator on the Lander Imaging Science Team.

Dr. Halpern is a co-investigator on one of the Lunar Sample Analysis Teams.

Drs. Lederberg, Levinthal and Halpern have been supported in these activities by other members of the Instrumentation Research Laboratory.

XII. Environmental Perspective

As part of our practice of investing a modest portion of our effort into the exploration of new areas of potential mutual interest to NASA and to our laboratory, two members of our group with a particular interest and involvement with environmental issues have sought to develop an environmental overview. As an incentive for the orderly collection of the material and an outlet for their findings, they are in the process of presenting a unique type of course in the university system entitled "Population, Technology, and Environment - A Search for Perspective."

The emphasis in the course is on the presentation of fundamental data and facts with regard to basic properties and resources of the physical and biotic global and domestic environment. Human influence upon the environment is then developed, with particular emphasis being devoted to immediate insults to the life system, to potentially irreversible alterations of the environment, and to the exhaustion of non-renewable resources. The last part of the course will be devoted to a discussion of remedial actions.

XIII.

REPORTS, PUBLICATIONS AND PAPERS

July 1, 1969 - Jan. 1, 1970

PUBLICATIONS

1. G. W. Hodgson, E. Peterson, K. A. Kvenvolden, E. Bunnenberg, B. Halpern, C. Ponnampereuma, "Search for Porphyrins in Lunar Dust Returned from Apollo 11," Science 167, 763 (1970).
2. C. Ponnampereuma, K. Kvenvolden, S. Chang, R. Johnson, G. Pollock, D. Philpott, I. Kaplan, J. Smith, J. W. Schopf, C. Gehrke, G. Hodgson, I. A. Breger, B. Halpern, A. Duffield, K. Krauskopf, E. Barghoorn, H. Holland, K. Keil, "Search for Organic Compounds in the Lunar Dust from the Sea of Tranquillity," Science 167, 760 (1970).
3. B. Halpern, G. W. Hodgson, E. Bunnenberg, E. Peterson, K. Kvenvolden, C. Ponnampereuma, "Search for Organic Matter on the Moon," Geochimica et Cosmochimica Acta (in press, 1970).
4. W. Pereira, V. A. Bacon, W. Patton and G. E. Pollock, B. Halpern, "The Use of Phenylethylisocyanate in the Optical Analysis of Asymmetric Secondary Alcohols by G.L.C.," Anal. Let. 3, 23 (1970).
5. I. S. Forrest, L. G. Brooks, S. D. Rose, B. Halpern, V. A. Bacon, and J. Silberg, "Fluorescent Labelling of Psychoactive Drugs," Agressologie (in press, 1970).
6. W. Pereira, V. Close, W. Patton, and B. Halpern, "Transesterification with an Anion-Exchange Resin," Jour. Org. Chem. 34, 2032 (1969).
7. W. Pereira, V. A. Close, E. Jellum, W. Patton and B. Halpern, "Alcoholysis of the Merrifield-Type Peptide-Polymer Bond with an Anion Exchange Resin," Aust. J. Chem. 22, 1377-40 (1969).
8. B. Halpern, "Optical Activity" for "Exobiology and the Exploration of Mars," Applied Optics 8, 1349 (1969).
9. B. Halpern, W. Patton and P. Crabbe, "Cotton Effect of Some Derivatives of Amino Acids and Amino Alcohols," J. Chem. Soc. B, 1143 (1969).
10. E. Jellum, V. A. Close, W. Patton, W. Pereira, and B. Halpern, "A Gas-Liquid Chromatographic Method for the Determination of Phenylalanine in Serum," Anal. Biochem. 31, 227 (1969).

11. V. Bacon, E. Jellum, W. Patton, W. Pereira, and B. Halpern, "Peptide Sequencing by Low Resolution Mass Spectrometry I. The Use of Acetylacetyl Derivatives to Identify N-Terminal Residues," Biochem. and Biophys. Res. Comm. 37, No. 6, 1969.
12. E. Jellum, V. A. Bacon, W. Patton, W. Pereira, Jr., and B. Halpern, "Quantitative Determination of Biologically Important Thiols and Disulfides by Gas-Liquid Chromatography," Anal. Biochem. 31, 339-347 (1969).
13. W. Patton, E. Jellum, D. Nitecki, W. Pereira and B. Halpern, "The Modification of Phenylalanine Containing Cyclo-Peptides with Nitrosyl Chloride," Aust. J. Chem. 22, 2709 (1969).
14. D. P. L. Sachs, E. Jellum and B. Halpern, "Determination of the Stereospecific Hydrolytic Action of Peptsin by Nuclear Magnetic Resonance Spectroscopy," Biochim. Biophys. Acta 198, 88 (1970).
15. S. Liebes, Jr., "Brightness - On the Ray Invariance of B/n^2 ," Am. Jour. Phys. 37 (9), 932 (1969).
16. H. R. Hulett, W. A. Bonner, J. Barrett, L. A. Herzenberg, "Cell Sorting: Automated Separation of Mammalian Cells as a Function of Intracellular Fluorescence," Science 166, 747 (1969).
17. S. Liebes, Jr., "Gravitational Lens Simulator," Am. J. Physics 37, 103 (1969).
18. H. R. Hulett, L. A. Herzenberg, W. A. Bonner, P. L. Wolf, "Rapid Cell Sorter - A New Tool for Cell Study with Clinical Applications," Laboratory Investigations (in press). To be presented at the 59th Annual Meeting of the International Academy of Pathology, Mar. 10-14, 1970, St. Louis, Mo.