



E000715

PROFILE: NORTHEAST OHIO REGIONAL MEDICAL PROGRAM

Grantee: Northeast Ohio RMP (a not for
profit corporation)

Current Chief Executive:
Barry Decker, M.D.

Profile originally prepared by:
Michael J. Posta

Original date: December, 1969

Updated: _____

TABLE OF CONTENTS

Map of the Northeast Ohio Regional Medical Program

- I. Geography
- II. Demography Data
 - Population
 - Land Area
 - Health Statistics
 - Facilities Statistics
 - Personnel Statistics
- III. Politics
- IV. Historical Review
- V. Core Staff
- VI. Organizational Makeup
- VII. Grand Design (to be completed when Region becomes operational)
- VIII. Operational Projects

NORTHEAST OHIO REGIONAL MEDICAL PROGRAM

12 Counties
and
Principle Cities

Population:

- 3,781,772 - 1960 Census
- 4,178,000 - 1967 Estimate
- 4,517,000 - 1970 Estimate

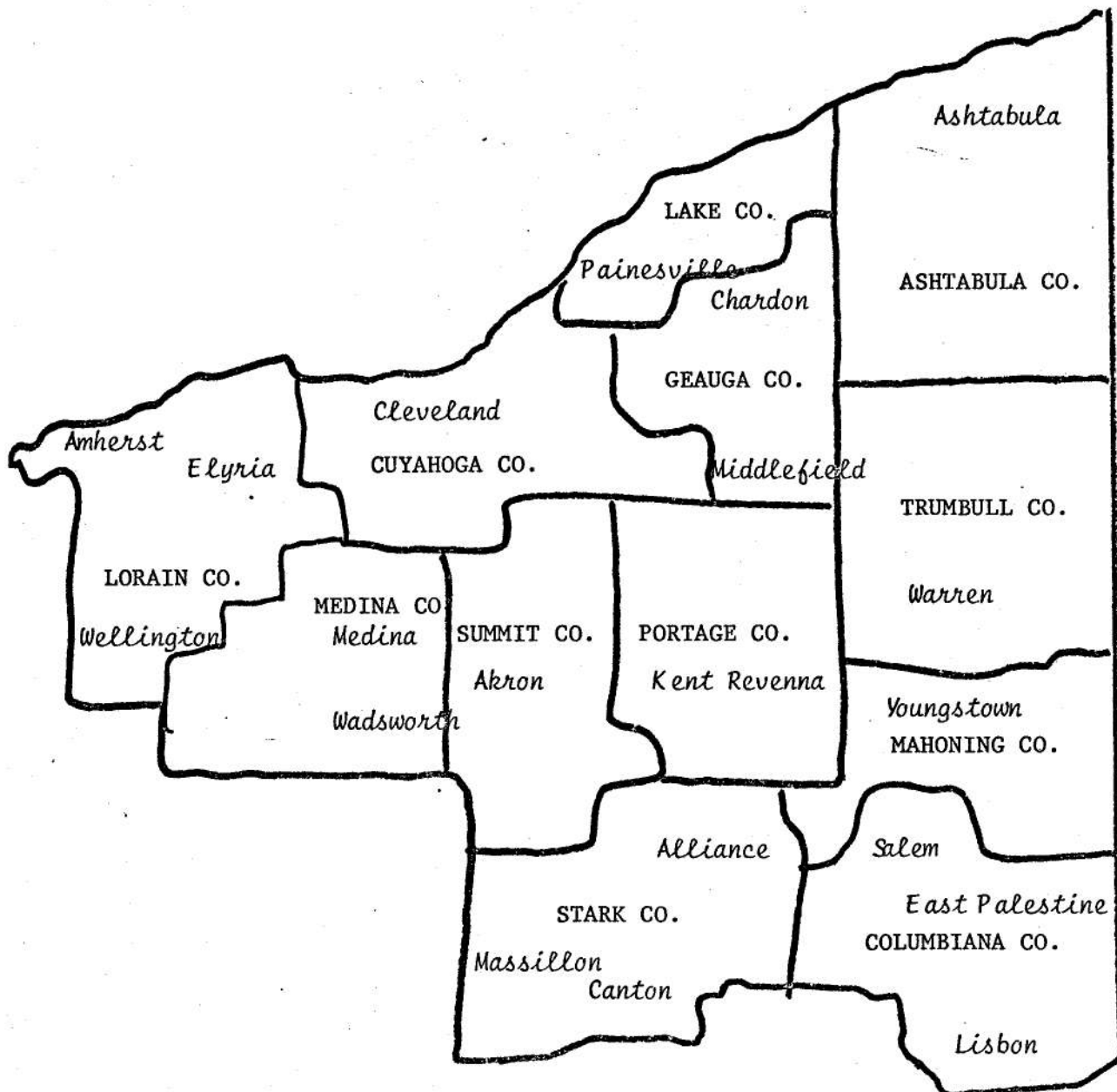

I. GEOGRAPHY

- 1) The Northeast Ohio Regional Medical Program is comprised of the twelve counties located in the extreme Northeastern section of Ohio.
- 2) Principal cities include Cleveland, Akron, Youngstown, Warren, Ashtabula, Lorraine, Painesville and Salem. (see map on preceeding page)
- 3) The grantee (Northeastern Ohio Regional Medical Program) was incorporated as "a not for profit" Ohio corporation simultaneously with the approval of the initial planning grant award.
- 4) The Case Western Reserve University School of Medicine is the sole Medical College located in the Northeast Ohio Region.
- 5) Six geographical sub-regional areas have been established which provide for local planning and participation in many program activities (see Organizational Chart - Section VI).
- 6) Thirty-seven defined subregional postal zones have been utilized in establishing demography, mortality and hospital utilization data.

II. DEMOGRAPHY

- 1) Population: Estimated 4,178,000 (1967)
 - a) Roughly 70% urban; Cuyahoga County is nearly 100% while Geauga County is only 9.3%; Others range from 43 to 79%.
 - b) Roughly 88% white; Cuyahoga County is 17% non-white; Mohoning County is 12% non-white; other counties range from 1 to 8%.

- 2) Land area: 5,784 Square miles

- 3) Health Statistics:
 - a) Mortality rate for Heart Disease--373/100,000
 - b) Rate for Cancer--164/100,000
 - c) Rate for CNS Vascular Lesions--90/100,000

- 4) Facilities Statistics:
 - a) Medical School: Case Western Reserve University, Cleveland, Ohio; enrollment - 340
 - b) There are seven schools of nursing
 - c) There are eighteen schools of medical technology; six schools of cytology (5 at hospitals)
 - d) As of 1967, there were 72 hospitals with approximately 18,290 beds; two are long-term with 505 beds; 10 are osteopathic hospitals.

- 5) Personnel Statistics:
 - a) As of 1969, there were 6,570 MDs practicing in the Region. Also 345 osteopaths were active.
 - b) As of 1969 there were 19,523 registered nurses (12,885 were employed)
 - c) Dentists - 2,150
 - d) Physical Therapists - 189
 - e) Occupational Therapists - 49
 - f) Social Workers - 107 (hospital employed, only)

III. POLITICS -- As of August 1969

Senators:

Stephen M. Young (D) - Special Committee on Aging, Aeronautical and Space Sciences, Armed Services, Public Works

William B. Saxbe (R) - Aeronautical and Space Sciences, Labor & Public Welfare, Special Committee on Aging

Representatives

J. William Stanton (R) - District 11; Banking and Currency, Select Committee on Small Business

Charles Mosher (R) - District 13; Merchant Marine & Fisheries; Science & Astronautics

Frank T. Bow (R) - District 16; Appropriations, Joint Committee on Reduction

Wayne L. Hays (D) - District 18; Foreign Affairs, House Administration, Select Committee on Parking

Michael J. Kirwan (D) - District 19; Appropriations, Joint Committee on Reduction of Federal Expenditures

Michael A. Feighan (D) - District 20; Judiciary, Merchant Marine and Fisheries; Joint Committee on Immigration and Nationality Policy

Louis Stohes (D) - District 21; Education & Labor, Internal Security

Charles A. Vanik (D) - District 22; Ways and Means

William E. Minshall (R) - District 23; Appropriations

IV. HISTORICAL REVIEW

Spring, 1966

- Deans of eight medical schools (Cincinnati, Ohio State, Case Western Reserve, Pittsburgh, Indiana, Kentucky, West Virginia and Louisville) met and determined that the geographical area to be served by these eight schools was too extensive and too heterogeneous to be organized into a single regional medical program.

Fall, 1966

- 1) The Academy of Medicine of Cleveland expressed initial interest in establishing a RMP in Northeast Ohio.
- 2) An advisory group of 162 members was formed: Composition include representatives of the Academy of Medicine of Cleveland, the Case Western Reserve University School of Medicine, presidents from adjacent county medical societies, the Heart and Cancer Association of Northeast Ohio and various voluntary health, lay, labor and business groups.
- 3) Dr. Irvine Page, Emeritus Consultant, Division of Research, Cleveland Clinic was elected Chairman of the advisory group.

February 3, 1967

- 1) Executive Committee appointed from above Advisory Group to further explore feasibility of potential program.
- 2) Dr. Frederick C. Robbins, Dean, Case Western Reserve University School of Medicine was designated Chairman.

August 3, 1967

- Health officials of the twelve county area endorsed the planning grant application.

October 10, 11, 1967

- Initial planning grant approved by DRMP.
 - 1) Reviewers were impressed with the intent of the application.
 - a) "Medical facilities are extensive with many outstanding general hospitals"
 - b) "Cohesive quality is strengthened by the fact that most of the physicians are graduates of Case Western Reserve or undertook residencies and/or internships in one or another of the hospitals in the Region.

January 1, 1968

- First year planning grant awarded for \$267,911 (D.C.).

June 1, 1968

- 1) A "not for profit" Ohio Corporation was established.
- 2) Former Executive Committee becomes the first Board of Trustees.
- 3) Dr. Barry Decker (present Program Coordinator) was employed.
- 4) Until this date, Region experienced problems in recruiting qualified personnel; therefore:

July 1, 1968

- 1) No planning activities were undertaken during the initial five months.
- 2) A six-month extension to the 01 planning grant was requested; approved by DRMP.

Progress of 01 year planning (1½ years):

- 1) 350 volunteer physicians, nurses, allied health professional and interested members of the public representing hospitals, agencies, institutions and communities were organized in a interdependent committee structure.
- 2) Data collection needs were identified and five well-conceived publications on health related data were compiled and distributed. Quantitative studies included:
 - a) regional inventories of manpower, facilities and training programs.
 - b) physician attitudes toward continuing education.
 - c) demography, mortality and hospital utilization in 37 defined subregional zones.
 - d) study of hospital use in relation to medical need.
- 3) Internal organization of the Region was developed (see Organization, Section VII).

4) Strategy (route towards achieving goals) of the NEORMP established to include:

- a) pre-planning 1967 - June 1968
- b) organizational development - December 1968
- c) data gathering - through June 1969
- d) Input-output design - August, September 1969
- e) Categorical project design based on available data
- f) operational transition - January 1970 through June 1970
- g) project design from September - July 1970

May 1969

- National Advisory Council approves - planning grant for 02 year \$462,662 (D.C.) for 7/1/69 - 6/30/70.

July 1969

- Division approves expenditure of \$10,000 (subcontract) for Library network feasibility study.

August 1969

- DRMP staff approve expenditure for feasibility study concerning laser beam television service. (\$3,000)

November 5, 1969

- Regional Advisory Group met and formally voted approval for:
 - 1) The priorities established
 - 2) The initial operational grant request including 10 projects.
 - 3) The budget with provision for review by the Board of Trustees before the newly budgeted positions are filled.

November 20, 1969

- Writer visited Program Coordinator for details necessary for the preparation of this profile.

December 1, 1969

- Initial operational grant application submitted to DRMP.

V. THE "CORE STAFF" OF THE NEORMP

The "core staff" of the NEORMP is described by the following table of organization with newly requested positions starred:

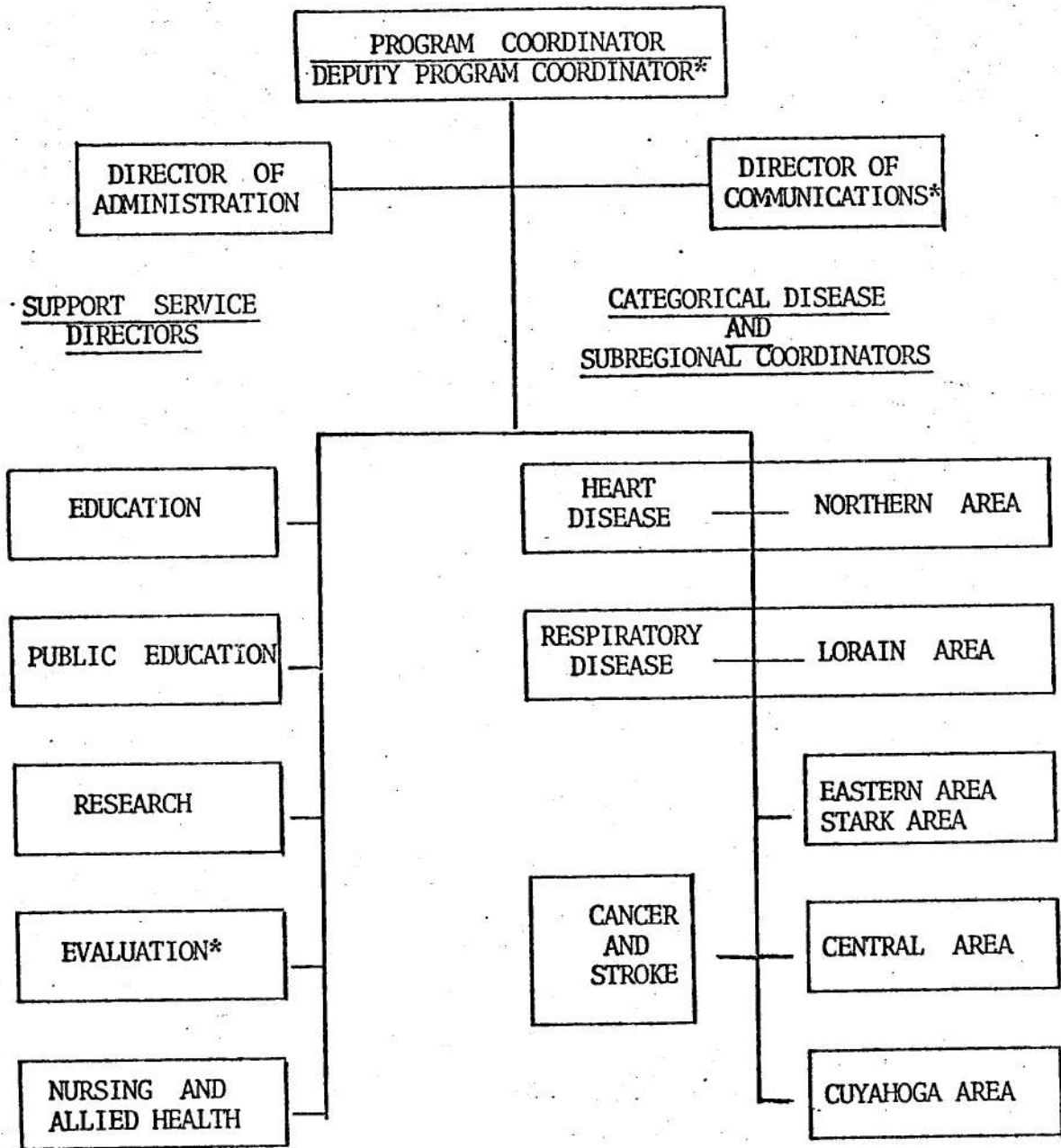

The persons employed, their location, committee and other responsibilities are described in the following table followed by curriculum vitae for currently employed staff and the chairmen of the RAG and Board of Trustees.

POSITION	PERSON	% TIME	LOCATION	COMMITTEES AND OTHER RESPONSIBILITIES
Program Coordinator	Barry Decker, M.D.	100%	NEORMP	Board of Trustees Regional Advisory Group Program direction and coordination, liaison to RMPS and other local agencies
Deputy Program Coordinator	(to be employed) 7/1/70	100%	NEORMP	Project review activities, assume coordinator's responsibility in absence of coordinator
Director Administration	Richard Meloy	100%	NEORMP	Fiscal management, supervision of affiliating relationships, office management
Director Communications	(to be employed) 7/1/70	100%	NEORMP	Publications Internal communications Public relations
Director Education	E. Bart Johnson, M.A.	100%	NEORMP	Education Committee and Subcommittee
Director Public Education	Lowell Bernard, M.P.H.	50%	Cleveland Health Museum	Public Education Subcommittee
Director Research	James Suter, M.S.	100%	NEORMP	Health Service Committee Health Data Committee
Director Evaluation	(to be employed) 7/1/70	100%	NEORMP	Project and Program Evaluation
Director Nursing and Allied Health Programs	(to be employed) 1/1/70	100%	NEORMP	Allied Health Subcommittee
Asst. Director	Arthur Lifson, M.S.	100%	NEORMP	Heart Disease Northern Area

Pertinent Staff Support Services
 To Listed Committees, Other Committees
 And Project Designers

POSITION	PERSON	% TIME	LOCATION	COMMITTEES AND OTHER RESPONSIBILITIES	Pertinent Staff Support Services To Listed Committees, Other Committees And Project Designers
Assistant Director	Martha McCrary, R.N. M.A.	100%	NEORMP	Respiratory Disease Lorain Area	
Assistant Director	Hiram Nickerson, M.A., M.P.H.	100%	NEORMP	Cancer Stroke	
Assistant Director	Mary Wheeler	100%	NEORMP	Cuyahoga Area	
Assistant Director	Jean Baird, R.N., M.S.	100%	Mahoning Valley Health Planning Corporation	Eastern Area Stark Area	
Assistant Director	(to be employed) 12/1/69	100%	Summit-Portage Health Planning Corporation	Central Area	

BIOGRAPHICAL INFORMATION

- 1) Barry Decker, M.D. - Program Coordinator
 - a) Born New York City, 1928
 - b) AB, Columbia College, 1948
 - c) M.D., N.Y.U. College of Medicine, 1952
 - d) M.S., Minnesota, 1958
 - e) Director, Medical Education, Richmond, Virginia, Memorial Hospital, 1961 - 1966
 - f) Private Practice, Internal Medicine & Pheumatology, 1961 - 1964
 - g) Medical Director, Chief of Staff, Youngstown, Ohio, Hospital Association, 1966-1968

- 2) Richard C. Meloy - Director of Administration
 - a) Born Detroit, Michigan, June 12, 1911
 - b) BS, Trinity College, Hartford, Connecticut, 1932
 - c) Customer Research Staff, General Motors, 1933-1939
 - d) Supervisor of Customer Research, Dayton, Ohio, 1939-1944
 - e) Manager, Market Research, Delco Division of General Motors, 1948-56
 - f) Marketing Director, Gray Inn Founders Society, Cleveland, 1956-63
 - g) Proprieter, National Auto Dealers Service Franchise, Rochester, New York, 1963-1968

- 3) E. Bart Johnson - Director of Education
 - a) Born Clinton, Iowa, March 10, 1926
 - b) AB and MA, State Univ. of Iowa, 1951
 - c) Ed. D.(Candidate) 1961 - present, Case Western Reserve
 - d) Instructor and Admin. Assistant, Medical College of Ga., 1957-59
 - e) Research Assoc. & Director, Health Studies Program, Case 1959-63
 - f) Assoc. Professor & Counselor, Cuyahoga Community College, 1963-69

- 4) James Suter, M.S. - Director of Research
 - a) Born London, England, January 30, 1932
 - b) AB and MA, Psychology, George Washington U. - 1958
 - c) Ph.D. Candidate (expected 1970)
 - d) Personnel Management Specialist - Office of S.G., USPHS, 1959-60
 - e) Chief, Intramural Research, Div. of Hospital & Medical Facilities - Bethesda - 1966-1968
 - f) Chief, Regional Health Facilities & Services Section, Bethesda, 1968-1969

5) Charles L. Hudson, M.D., Chairman, RAG

- a) Born Merrill Michigan, 1904
- b) AB, Alma College, Michigan, 1924
- c) M.D., Univ. of Michigan, 1930
- d) University Hospitals of Cleveland, 1930-1962
- e) Director, University Health Service, Western Reserve Univ., 1958-61
- f) Assoc. Professor Medicine, Cleveland Clinic Educational Foundation, 1962 to date

6) Frederick C. Robbins, M.D., Chairman, Board of Trustees

- a) Born Auburn, Alabama, August, 1916
- b) AB and BS, University of Missouri, 1938
- c) MD, Harvard, 1940
- d) Intern, Resident, Research Fellow, Harvard, 1940-1950
- e) Pediatrics, Harvard, 1951-1966
- f) Associate Pediatrician, University Hospital, Cleveland, 1952-present
- g) Dean, School of Medicine, Case Western Reserve Univ., 1966-present

VI. Organization of the Northeast Ohio Regional Medical Program

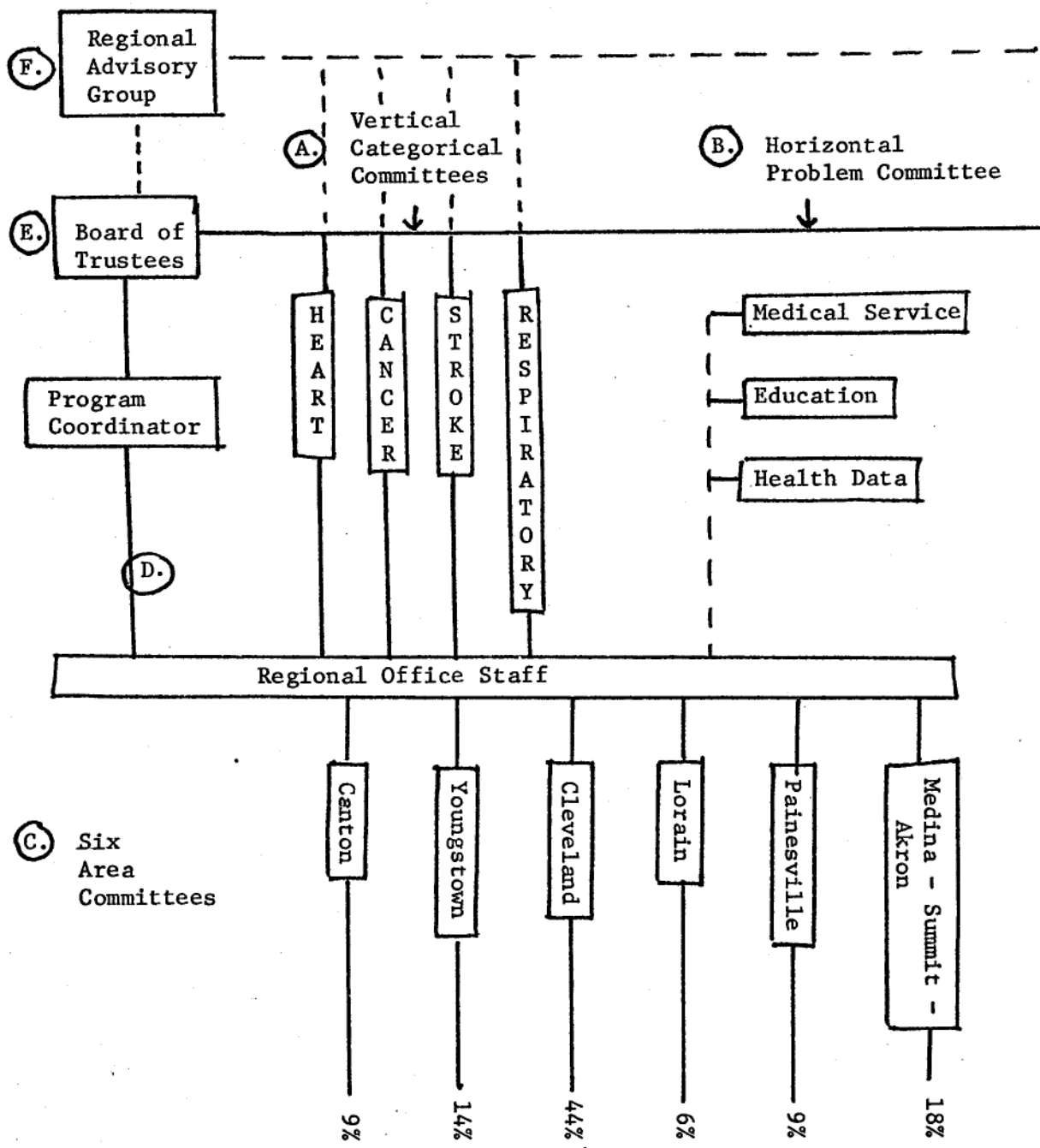

A. Categorical Disease Committees:

- 1) The Heart, Cancer, Stroke and Respiratory Disease Committees (See above chart) are composed of disease experts from throughout the twelve county Region.
- 2) They consist primarily of physicians who are charged with problem identification and project design within their respective disease concerns.
- 3) Diabetes and renal disease are assigned to the Heart Committee.

B. Horizontal Committees:

Because problems of Medical Service, Education and Health Data Collection transcend beyond disease borders, separate committees, which are broadly representative of the twelve counties, have been developed to establish problem identification and project design in their titular areas of concern.

- 1) The Medical Service Committee is composed of public health officials hospital or clinic administration representatives, community service agencies and medical staff administration personnel.
- 2) The Education Committee is composed of university teachers, hospital directors of medical education, nurse educators and voluntary health agency personnel.
- 3) The Health Data Committee integrates the skills of the statistician and data processor with the perspective of the physician and the community or hospital service agency administrator.

C. Area Committees:

- 1) Twelve counties of the Region have been subdivided into six areas having "natural trade and professional relationships."
- 2) The percentage of the Region's total population, to each of the six areas, are noted on the chart above.
- 3) Committees were established by local agreement to more effectively involve the local professionals and their institutions and to more adequately recognize "grass-root" problems and needs.
- 4) The six committees represent the health providers of the area.

The above three types of committees (A, B & C) functions are:

- a) problem identification and project design
- b) review of projects submitted by affiliated agencies
- c) consultation for other committees

D. Program Coordinator and Regional Office Staff (Core):

- 1) The program coordinator is the primary agent of the Board of Trustees and, as chief executive officer, is accountable to the Board for the proper functioning of the NEORMP.
- 2) The Core staff is included in the previous Section (V).
- 3) Total expenditures for personnel was \$300,000 during the 02 planning grant year. (7/1/69 - 6/30/70)

E. The Board of Trustees:

- 1) Consists of 14 annually appointed members who elect their chairman.
- 2) Meets monthly. (Hope to have a Board member from each of the six sub-regional areas and representation for the major disciplines of medicine, nursing and hospital administration).
- 3) The Board was originally the Executive Committee of the RAG and assumed trustee responsibilities when NEORMP became a not for profit corporation of Ohio.

The Board:

- a) establishes policy and supervises the Program Coordinator's implementation of these policies.
- b) continues to function as Executive Committee of RAG.
- c) recommends priority rating of specific projects.

F. The Regional Advisory Group:

- 1) Is representative of health disciplines, disease interest and geographical areas.
- 2) Includes:
 - a) Chairman and two additional members from each of the 13 committees (A, B, C) = 39
 - b) 14 Members of the Board of Trustees
 - c) 18 at-large members
- 3) The 71 member RAG meets 4 times a year to:
 - a) receive progress reports
 - b) review projects and priorities submitted by the Board of Trustees

- 4) All members have detailed prior knowledge of projects which allows for greater involvement of these participants.
- 5) Consists of:

7	Practicing physicians
5	Medical Center Officials
*13	Hospital representatives
15	Medical Societies
4	Other Health Professions
12	Comm. Health Welfare Hosp. Planning Agencies
5	Voluntary Health Agencies
9	Public
1	Health Departments
<u>71</u>	TOTAL

*Two are hospital administrators - balance are M.D.'s, chief's of hospital staffs and one Director of Medical Education.

Project Initiation and Review Process:

Projects can be initiated by any of the Committees of the NEORMP or by any non-profit agency or health organization in Region.

All grant requests have the same review process:

- 1) Staff will initially review all applications to insure the inclusion of necessary and pertinent material.
- 2) Referred to appropriate expert Committee or Committees.
- 3) All go to area Committees for opinions regarding local applicability. Following review, modification and re-review, projects:
- 4) Are submitted to Board of Trustees for approval, priority rating and referral to
- 5) RAG; all approved are submitted to
- 6) Division of Regional Medical Programs in order of RAG priority. Worksheets are used in the evaluation of all project applications. This Grant Evaluation Form is used by staff, appropriate Committees, the Board and the RAG. Form requires comment on project's a) concept, b) feasibility, c) need, d) interrelations, e) regionalization, f) relevance to PL 89-239, g) relative value, h) adequacy of proposed evaluation. This form creates a cover sheet for each application and permits each visualization of projects through a multi-stage evaluation.

VIII. SUMMARY OF PROPOSITIONAL PROJECTS

PROJECT	NEOVR PRIORITY	GRANT RECIPIENT	FUNDING DURATION
1) NEORMP "Core" Support		NEORMP	3 Years
2) Hospital Library Consulting Services	I	Cleveland Health Sciences Library Case Western Reserve University	3 Years
3) Northeast Ohio Regional Program for Continuing Education of Nurses in Coronary Care	II	American Heart Association, Northeast Ohio Chapter	3 Years
4) Rheumatic Fever Prevention by a Streptococcal Culture Program	II	American Heart Association, Northeast Ohio Chapter	3 Years
5) Organization for University Cooperation in Health (OUCH)	II	Metropolitan Health Planning Corporation	2 Years
6) Continuing Education for Physical Therapy	II	Physical Therapy Graduate Curriculum, Case Western Reserve University	3 Years
7) Televised Postgraduate Medical Education Programs	III	Cleveland Academy of Medicine	3 Years
8) A Comprehensive Out-Patient Stroke Rehabilitation Demonstration	III	Lake County Society for Crippled Children and Adults	3 Years
9) Dial Access Lectures	III	NEORMP	3 Years
10) Summer Workshop in Career Development	IV	Cleveland Health Museum - Kent State University	3 Years
11) Medical Taxi Services for Residents of Rural Geauga County	IV	Geauga County Medical Society	2 Years