

W2
A2
qW2f
no. 21-40
1940

Med. Library

FM 21-40

DOCUMENT

3

WAR DEPARTMENT

HMD

BASIC FIELD MANUAL

DEFENSE AGAINST
CHEMICAL ATTACK

Feb
1940

INDEXED

1940 ed.

JAN 7 1940
LIBRARY

ARMY
MEDICAL
JAN 17 1952
LIBRARY





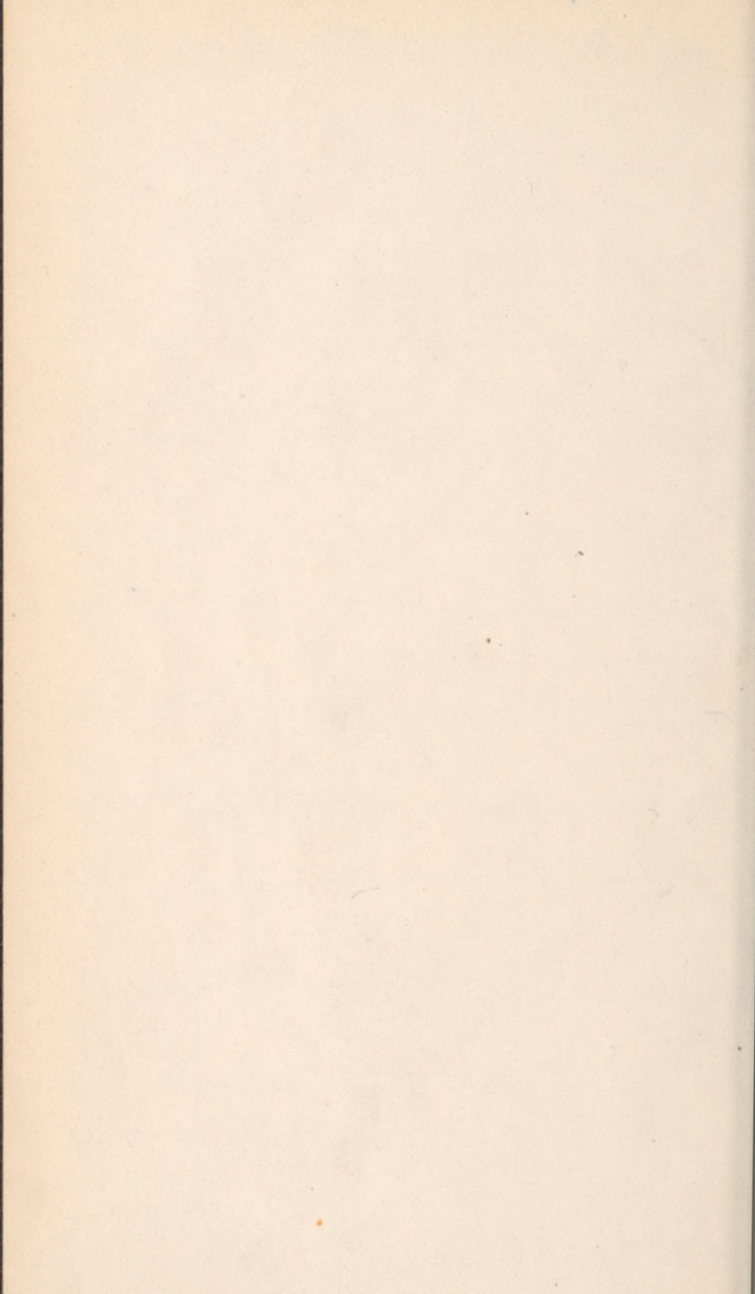

War Dept.

FM 21-40

(BASIC) FIELD MANUAL

DEFENSE AGAINST CHEMICAL
ATTACK

Prepared under direction of the
Chief of the Chemical Warfare Service

U.S. War Department



INDEXED

UNITED STATES
GOVERNMENT PRINTING OFFICE
WASHINGTON: 1940

WR
AR
WRf
no. 21-40
1940
c. 1

WAR DEPARTMENT,
WASHINGTON, May 1, 1940.

FM 21-40, Defense Against Chemical Attack, is published for the information and guidance of all concerned.

[A.G. 062.11 (2-28-40).]

BY ORDER OF THE SECRETARY OF WAR:

G. C. MARSHALL,
Chief of Staff.

OFFICIAL:

E. S. ADAMS,
Major General,
The Adjutant General.

TABLE OF CONTENTS

	Paragraphs	Page
SECTION I. General-----	1-3	1
II. Principal chemical agents-----	4-6	3
III. Use of chemical agents in the field-----	7-17	12
IV. Protection and protective equipment---	18-27	23
V. The gas mask-----	28-34	28
VI. First aid for gas casualties-----	35-40	72
VII. Organization and duties of personnel---	41-49	75
VIII. Tactical protection-----	50-57	84
IX. Training in defense against chemical attack-----	58-68	96
X. Animal protection-----	69-76	113
XI. Training mask MI-----	77-84	124
APPENDIX. Form for standing orders-----		144
INDEX-----		146

BASIC FIELD MANUAL

DEFENSE AGAINST CHEMICAL ATTACK

(The matter contained herein supersedes chapter 8, Basic Field Manual, volume I, December 31, 1937 (including C1, May 25, 1939).)

SECTION I

GENERAL

■ 1. OBJECT OF INSTRUCTION.—The object of instruction and training in defense against chemical attack is to—

- a. Minimize casualties from enemy chemical attacks.
- b. Prevent undue interruption to normal military action during combat.

■ 2. SCOPE OF INSTRUCTION.—The scope of instruction includes—

- a. A description of chemical agents that may be encountered in the field, their properties and physiological effects.
- b. Effects of weather and terrain on the use of chemical agents.
- c. Methods of projecting chemical agents.
- d. Use and care of protective equipment.
- e. Methods of decontaminating areas and equipment.
- f. First-aid treatment for gas casualties.
- g. Organization and duties of individuals in defense against chemical attack.
- h. Duties of gas sentries.
- i. Tactical protective measures against chemical attacks.

■ 3. STANDARDS OF PROFICIENCY.—*a. The individual.*—The individual soldier will be proficient in the essentials of defense against chemical attack described in sections I to VII, inclusive. In addition, officers and gas noncommissioned officers will be proficient in their duties as prescribed in sections VIII and IX. An outline of standards of proficiency in the protection of the individual is given below:

(1) *Chemical agents.*—(a) Ability to identify a chemical agent in the field by odor, color, and physical state.

- (b) Knowledge of—
1. Persistency of the principal gases.
 2. Effect produced on the body upon contact with the agent.
 3. Protection required against all classes of agents.
 4. Methods of decontaminating areas and equipment.
- (2) *First-aid treatment for gas casualties.*—(a) Recognition of the effects of agents.
- (b) Differentiation between seriously and slightly gassed cases.
- (c) Application of remedial measures pending medical aid.
- (3) *Protection.*—(a) *Gas mask.*
1. Proficiency in gas mask drill.
 2. Knowledge of kind and degree of protection afforded by the gas mask.
 3. Knowledge of when to use and remove the gas mask.
 4. Ability to take proper care of the gas mask.
- (b) *Protective clothing.*
1. Knowledge of when and how to use protective clothing.
 2. Knowledge of proper care of protective clothing.
- (c) *Gasproof shelters.*
1. Knowledge of requirements to make a shelter gasproof; methods of entering and leaving gasproof shelters; method of clearing gas from shelters.
 2. Ability to determine the presence of gas in a shelter.
- (d) *Protection of animals.*
1. Knowledge of use of protective equipment for animals.
 2. Ability to assist the animal in securing protection.
- (4) *Duties of gas sentries.*—(a) Ability to detect agents in the field by odor, color, and physical state, sounding the gas alarm only when necessary.
- (b) Knowledge of weather and terrain conditions favorable for enemy attack by chemical agents.
- (c) Ability to recognize sounds indicating probable installation of weapons and projection of chemical agents by the enemy.

b. *The organization.*—The proficiency of an organization in defense against chemical attack depends primarily on the proficiency of every member thereof as prescribed in *a* above. In addition, it requires the availability of the prescribed quota of gas officers and gas noncommissioned officers, and the necessary number of trained gas sentries and gas reconnaissance personnel to meet the probable requirements of combat. It also includes the maintenance in serviceable condition of adequate protective clothing, protective equipment, and protective supplies and the training of the unit as a whole so that it will efficiently take the collective measures and carry out the tactical procedure prescribed herein.

SECTION II

PRINCIPAL CHEMICAL AGENTS

■ 4. DEFINITIONS.—*a.* A *chemical agent* is a substance useful in war which, after release and acting directly through its chemical properties, is capable of producing a toxic effect, a powerful irritant effect, a screening smoke, or an incendiary action.

b. A *persistent agent* is one which will maintain an effective vapor concentration in the air at point of release for more than 10 minutes. An effective concentration is one which necessitates protection of any kind. Some persistents last for days and even weeks.

c. A *nonpersistent agent* is one whose effectiveness in the air at point of release is dissipated within 10 minutes.

d. A *casualty agent* is a material of such physical and chemical characteristics that a dangerous or killing concentration can be set up under conditions encountered in the field. Casualty agents are therefore used directly against personnel for the primary purpose of producing casualties.

e. A *harassing agent* is one used to force masking and thus slow up enemy operations. Only those agents which produce this result with the expenditure of small quantities of ammunition are considered primarily as harassing agents. Lacrimators and irritant smokes are the principal agents of this type.

f. An incendiary is a chemical agent used primarily for setting fire to matériel. It may produce casualties due to heat burns.

g. A lung irritant is a chemical agent which, when breathed, causes irritation and inflammation of the interior portion of the bronchial tubes and lungs. Its primary physiological action is limited to the respiratory tract.

h. A vesicant is a chemical agent which is readily absorbed or dissolved in both the exterior and interior parts of the human body, followed by the production of inflammation, burns, and destruction of tissue.

i. A lacrimator is a chemical agent which causes a copious flow of tears and intense, though temporary, eye pains.

j. An irritant smoke is a chemical agent which can be disseminated as extremely small solid or liquid particles in air, and when so disseminated, causes intolerable sneezing, coughing, lacrimation, or headache followed by nausea and temporary physical disability when breathed in very low concentrations.

k. A sternutator is an irritant smoke.

l. A screening smoke is a chemical agent used to blind hostile observation. With the exception of the burning action of particles of phosphorus or liquid FS on the skin, smokes have little or no injurious effect on personnel.

■ 5. CLASSIFICATION.—*a. Physical state.*—Chemical agents may be encountered as gases, liquids, or solids. This classification is based on their physical condition at ordinary temperatures likely to be encountered in the field.

b. Physiological effect.—Chemical agents affect particular parts of the body in several ways. They are classified for these physiological effects as—

(1) Lung irritants.

(2) Vesicants.

(3) Lacrimators.

(4) Irritant smokes.

(5) Incendiaries.

c. Tactical use.—Chemical agents are classified in accordance with their principal tactical use as—

(1) Casualty agents.

(2) Harassing agents.

(3) Screening agents.

(4) Incendiaries.

■ 6. CHARACTERISTICS.—The tables below give in brief form the practical information on chemical agents needed in the application of defensive measures against chemical attack. The agents listed are the principal types in each class and are therefore the most likely to be used in future warfare. Since other agents that may be employed will likely be variations of these types, a knowledge of the protective requirements for the agents shown will be of considerable value in meeting any problems of protection that may arise.

LUNG IRRITANTS

NAME and SYMBOL.	CHLORINE (Cl).	PHOSGENE (CG).	CHLORPICRIN (PS).
Odor.....	Disagreeable, pungent.....	Disagreeable, pungent, like new cut hay or cut corn.	Sweetish, like fly paper.
Color and state in field.....	Greenish yellow gas.....	First white, changing to colorless gas.	Oily liquid changing slowly in open to colorless gas.
Effects on body.....	<i>Lung irritant.</i> Causes choking and coughing, smarting of eyes, and discomfort in chest. A 2-minute exposure to an average field concentration produces a casualty. Effects begin immediately.	<i>Lung irritant.</i> Choking, coughing, hurried breathing, pains in chest due to irritation of lower lungs. Approximately nine times more toxic than chlorine; a few breaths in average field concentration produce a casualty. Effects begin immediately but progress slowly.	<i>Lung irritant and lachrimator.</i> Lacerimation, coughing, nausea, vomiting, lung irritation. Approximately one-half as toxic as phosgene.
First-aid treatment.....	Keep quiet and warm. Treat for bronchial pneumonia.	Keep quiet and warm; give heart stimulants; give oxygen in severe cases.	Remove to pure air. Keep quiet and warm. Give light stimulants. Wipe off splashes of liquid on skin with alcoholic disodium sulfite.
Persistence.....	Vaporizes almost immediately under field conditions. Drifts as gas with the wind but being heavier than air clings for some time in trenches, shell holes, woods, and other low or protected places.	Vaporizes almost immediately under field conditions. Gas remains considerable time in low or protected places.	1 to 12 hours.
Action on food and water.	Contaminates. In some cases may be removed by ventilation and heating but taste remains disagreeable.	Contaminates. In some cases may be removed by ventilation and heating but taste remains disagreeable.	Contaminates. In some cases may be removed by ventilation and heating but taste remains disagreeable.
Action on metal.....	Dry, none; wet, vigorous corrosion..	Dry, none; wet, vigorous corrosion..	Slight tarnish only.

How used.....	For casualty effects. In cloud gas attacks as substitute for phosgene or mixed with phosgene or chlorine in cylinders or Livens projectors.	For harassing and casualty effects. In shell, bombs, or airplane spray as substitute for other agents; in like manner mixed with CN; in cloud attacks mixed with Cl.
Protection required.....	Gas mask.....	Gas mask.

VESICANTS

NAME and SYMBOL	LEWISITE (ML).	MUSTARD (HS).
Odor.....	Like geraniums, then biting.	Like garlic or horseradish.
Color and state in field.....	Dark brown liquid, changing slowly into a colorless gas.	Dark brown liquid, changing slowly into a colorless gas.
Effects on body.....	<i>Vesicant, blisters skin.</i> Skin shows slight irritation in 15 minutes followed by grayish discoloration and blisters in 30 minutes to 1 hour. Systemic poisoning; vomiting. If breathed, powerful lung irritant effects within ½ hour. If unprotected, immediate irritation of eyes. Approximately six times as toxic as phosgene.	<i>Vesicant, blisters skin.</i> Symptoms delayed 2 to 4 hours. If exposed, eyes burn and inflame. Skin, in contact with gas or liquid, discolors, followed by blisters and sores. If breathed, hoarse cough develops followed by severe pain in chest and inflammation of lungs. Approximately four times as toxic as phosgene.
First-aid treatment.....	Wash with running water and soap, then with 5-percent aqueous solution of caustic soda followed by alcohol. Keep warm and quiet. Treatment must be given immediately. Evacuate to hospital.	Wash continuously with running water and strong soap, then apply carbon tetrachloride saturated with chlorine, or bleach solution. Wash eyes with boric acid or salt solution. Treatment must be given within a few minutes.
Persistence.....	Dispersed as liquid which slowly changes to gas. Rate of vaporization depends on temperature, vegetation, and method of dispersion. Rapidly destroyed by water. Summer: 24 hours in open; 2 or 3 days in woods. Winter: 1 week or more.	Dispersed as liquid which slowly changes to gas. Rate of vaporization depends on temperature, vegetation, and method of dispersion. Summer: 4 to 5 days in open; 1 week in woods. Winter: Several weeks.

VESICANTS—Continued

NAME and SYMBOL.	LEWISITE (ML).	MUSTARD (HS).
Action on food and water.	Poisons unprotected food and water. Cannot be made suitable for use.	Renders unprotected food and water unfit for use.
Action on metal.	Very slight.	Very slight.
How used.	<i>For casualty effect or to deny ground through threat of casualties. In artillery shell, mortar shell, airplane bombs, airplane spray, and land mines.</i>	<i>For casualty effect or to deny ground through threat of casualties. In artillery shell, mortar shell, airplane bombs, airplane spray, and land mines.</i>
Protection required.	Gas mask and protective clothing.	Gas mask and protective clothing.

LACRIMATORS

NAME and SYMBOL	CHLORACETOPHENONE	TEAR GAS SOLUTION (CNS)
Odor.....	Like apple blossoms.....	Like fly paper.
Color and state in field.....	Bluish gray smoke from burning type munition; colorless from shell.	A colorless liquid, changing to colorless gas.
Effects on body.....	Piercing irritation of eyes causing profuse tears. Effective in extremely low concentrations.	Piercing irritation of the eyes, profuse tears, followed by nausea and vomiting.
First-aid treatment.....	Wash affected parts with water.	First aid same as for lung irritant cases.
Persistency.....	Cloud from burning mixture drifts with wind. Will remain in low and protected places for some time. Shell or solid CN may remain several weeks.	Summer: 1 hour in open; 2 hours in woods. Winter: 6 hours in open; 1 week in woods.
Action on food and water.....	Gives unprotected food disagreeable odor.	Dispersed as liquid which changes to gas. Contaminates. In some cases may be removed by ventilation and heating.
Action on metals.....	Tarnishes steel slightly.....	Tarnishes steel slightly.
How used.....	<i>For harassing effect.</i> In grenades.	<i>For harassing effect.</i> In artillery shell, mortar shell, airplane bombs, and airplane spray.
Protection required.....	Gas mask.....	Gas mask.

IRRITANT SMOKES (STERNUTATORS)

NAME and SYMBOL	ADAMSITE (DM)	SNEEZE GAS (DA)
Odor.....	Not definite, slightly like coal smoke.	
Color and state in field.....	A yellow smoke cloud.	Greyish smoke cloud.
Effects on body.....	Immediate sneezing followed by headache, nausea, and vomiting. Temporary physical debility. Effective in low concentrations but is delayed about 5 to 10 minutes.	Sneezing and burning sensation of the nose and throat. Slight lacrimation followed by occasional nausea, headache, and temporary debility.
First aid treatment.....	Remove to pure air.....	Immediately effective. Remove to pure air.

IRRITANT SMOKES (STERNUTATORS)—Continued

NAME and SYMBOL	ADAMSITE (DM)	SNEEZE GAS(DA)
Persistency.....	While burning, drifts with the wind, will remain in low and protected places for some time. General, 5 minutes in open.	While burning, drifts with the wind, will remain in low and protected places for some time. General, 10 minutes in open.
Action on food and water.	Poisons unprotected food and water; cannot be made safe for use.	Poisons unprotected food and water; cannot be made safe for use.
Action on metals.....	Very slight.	Vigorous corrosion on steel.
How used.....	<i>For harassing effect.</i> In candles or generators.	<i>For harassing effect.</i> In candles or shell.
Protection required.	Gas mask with a good filter.	Gas mask with a good filter.

SCREENING SMOKES

NAME and SYMBOL	SULPHUR TRIOXIDE SOLUTION (FS).	HC MIXTURE	WHITE PHOSPHORUS (WP).
Odor.....	Acid or acid	Acrid, suffocating	Like phosphorus matches.
Color and state in field	Dispersed as liquid which changes to white smoke upon contact with air.	White smoke produced by burning munitions only.	Dispersed as solid which rapidly changes to flame and white smoke on contact with air.
Effects on body.....	Mild pricking sensation to skin; non-injurious.	None	Smoke, none; particles produce severe fire burns which heal very slowly.
First-aid treatment.....	Wash with copious amounts of water, then with sodium bicarbonate and treat as for ordinary burns.	None needed	Apply copper sulfate solution (CuSO ₄) (2 to 5 percent). This coats the particles with copper which effectively prevents oxidation. Pull out solid particles and treat like an ordinary burn. Keep burning part under water until medical attention arrives if no CuSO ₄ is available.
Action on food and water.	Liquid renders food and water unfit for use; smoke gives disagreeable odor.	Smoke gives disagreeable odor.	Smoke gives disagreeable odor; solid is poisonous.
Action on metal.....	Vigorous corrosion in presence of moisture.	None, if dry	None.
How used.....	<i>Screening smoke.</i> In airplane spray for screening; in artillery shell, mortar shell, and cylinders for training to simulate cloud gas.	<i>Screening smoke.</i> In smoke pots or candles, for training only.	<i>Screening smoke and incendiary.</i> In artillery shell and mortar shell, primarily for smoke effect; also used in same munitions and airplane bombs for casualty effect and incendiary action.
Protection required.....	None	None	For smoke, none; for burning particles, none provided.

SECTION III

USE OF CHEMICAL AGENTS IN THE FIELD

■ 7. OBJECT OF CHEMICAL ATTACK.—Chemical attacks are made with the following objects in view:

- a. To inflict casualties.
- b. To deny certain areas to an opposing force through threat of casualties.
- c. To contaminate matériel and supplies.
- d. To harass by forcing the opposing troops to mask, thereby reducing their efficiency.
- e. To affect morale.
- f. To interfere with observation by smoke.
- g. To destroy matériel and supplies by incendiary action.

■ 8. METHODS OF PROJECTING CHEMICAL AGENTS.—Chemical agents may be projected by the following methods:

- a. From artillery shell and mortar shell.
- b. From chemical projector shell.
- c. From aircraft, either in bombs or as a spray.
- d. From cylinders or gas candles in the form of a cloud.
- e. From bulk containers and chemical land mines placed in position and fired statically.
- f. Sprayed from vehicles.
- g. From hand and rifle grenades and smoke pots.

■ 9. CHEMICAL ARTILLERY AND MORTAR SHELL ATTACKS.—*a. Artillery shell.*—(1) The use of artillery gas shell is in large measure independent of wind direction, though not of wind velocity. Persistent agents of the mustard-gas type are suitable for projection from light artillery. Nonpersistent agents of the phosgene type are suitable for projection from medium artillery.

(2) Before an attack, only nonpersistent gases are likely to be used on the area over which the attack is to be made, although persistent agents may be used on other areas.

(3) The chemical content of artillery shell is small when compared by weight with other chemical containers. To produce an appreciable effect, chemical artillery shell must, therefore, be used in large numbers.

(4) The agents most likely to be projected by 75-mm shell are those of high persistency. The explosion of the shell

upon impact throws the agent over an area approximately 14 yards in diameter. The agents most likely to be projected by the 155-mm shell are mustard, lewisite, phosgene, and white phosphorus. Upon explosion of the 155-mm shell, the agent is thrown over an area approximately 50 yards in diameter. With both the 75-mm and the 155-mm shell, the area over which the agent is thrown is not centered on the point of impact but is generally slightly forward of the point of impact and slightly elongated in the direction of fire.

b. Mortar shell.—(1) Up to ranges of 2,400 yards, the chemical mortar can establish and maintain heavy concentrations of both persistent and nonpersistent gas. It is also suitable for firing white phosphorus for both smoke and casualty effects.

(2) The agents most likely to be used in mortars are mustard, lewisite, phosgene, and white phosphorus. The explosion of the shell of the 4.2-inch chemical mortar upon impact throws the agent over an area approximately 40 yards in diameter. (See fig. 1.)

c. Danger areas.—(1) Any point within the radius of burst of chemical shell, either artillery or mortar, is a danger area; and any person within such area may become a casualty unless proper protective measures are taken immediately.

(2) There is also a danger area extending downwind from the area of burst. In the case of nonpersistent agents, upon the explosion of the shell the liquid almost instantaneously changes into a gas and is borne downwind at the speed of the wind. This gas cloud spreads at about the rate of 15 percent of the distance traveled. It eventually becomes so thinned out by spread, settling out, and other causes, that the concentration is too weak to cause casualties. The distance downwind that the cloud is effective varies from two or three hundred yards for a single large caliber shell to several miles in the case of heavy concentrations over a wide front.

(3) In the case of the persistent gases, upon the explosion of the shell a portion of the liquid changes immediately into a gas and a portion is so finely atomized that it, too, travels with the wind. The remainder, in liquid form, is distributed over the ground and slowly changes into a gas, the rate depending upon the temperature. Thus, there is an extremely



FIGURE 1.—Burst of a white phosphorus filled 4.2-inch chemical mortar shell.

dangerous area downwind immediately after the burst of a mustard-gas shell.

Thereafter, until vaporization is complete, there continues to be an area downwind where there is a constant flow of mustard vapor; however, the concentration is much less and the effective distance downwind much less than that immediately following the burst of the shell.

(4) The distance downwind that a gas of high persistency is effective immediately following the burst of shell is considerably less than that of a nonpersistent gas. This distance for the highly persistent gases like mustard will vary from 200 yards downwind in the case of a single large capacity shell to 1,000 or more yards in the case of a large concentration projected over a wide front.

d. Types of attacks.—The enemy may employ the following types of chemical attacks:

(1) A short concentration on heavily occupied areas with nonpersistent gas for the purpose of inflicting casualties by surprise.

(2) Harassing fire at a slow rate with shell containing highly or moderately persistent chemical agents, such as lacrimatory or vesicant agents.

(3) Neutralization with highly persistent gas to render areas untenable and to inflict casualties upon personnel occupying them. Mustard gas is the type generally used for this purpose.

(4) Smoke screens to blanket observation, prevent aimed fire, screen troop movements, and inflict casualties.

(5) With incendiaries to set fire to stores, structures, and vegetation.

e. Detection of chemical shell.—A chemical shell containing a liquid can sometimes be distinguished from other shell by the peculiar intermittent whirring noise it makes in flight and usually by its low detonation sound.

f. Protective measures.—Protective measures will differ slightly depending upon the physiological type of gas encountered.

(1) In the case of a lung irritant gas, like phosgene, the proper measures are to stop breathing until the gas mask is correctly adjusted and to continue wearing the mask until

the gas concentration has dissipated. The time of mask wearing will vary.

Normally the agent from a single shell will last about 10 minutes, but if a bombardment is continued, the danger time is increased. Weather and terrain conditions at the defender's position may also greatly extend the effective time of this type of agent.

(2) For the vesicant gases, the protective measures include not only the prompt adjustment of the mask, but also the proper wearing of protective clothing. It must be remembered that persistent vesicants such as mustard gas and lewisite in the vapor state will affect eyes and skin and will injure lung tissue. In the liquid state, these vesicants may be absorbed directly on the clothing and thence transferred to the skin, or may be absorbed by vegetation, wood, concrete, and metal equipment, from which vapors may be given off or unnoticeable quantities of liquids transferred to the hands and thence to other parts of the body. Many wounds may be caused by this transference. If clothing and equipment become contaminated, they also include the prompt removal of such articles, the thorough cleansing of the body with soap and water, and the decontamination of the infected articles before they are again used. A portion of the liquid agent will remain in the area of burst for several days and during such time it will be dangerous for any person to enter this area unless completely protected with protective clothing.

■ 10. CHEMICAL PROJECTOR SHELL ATTACKS.—*a.* By means of chemical projectors, a large amount of gas can suddenly be set free. The cloud produced is of higher concentration than can be obtained in the field with any other chemical projectile.

b. The projector is a simple mortar designed to fire only one shot per installation. The projectors are usually installed in batteries of 25 which are fired simultaneously by an electric current. (See fig. 2.) Usually, many batteries are fired at one time against one target.

c. Nonpersistent casualty agents are usually employed in these shell. However, highly persistent agents may be projected, especially when the enemy is on the defensive. An

enemy may launch a projector attack in two salvos, the first being HE to produce casualties among men above ground and cause momentary confusion, and the second being a nonpersistent gas to reach men below ground and to produce additional casualties during the confusion caused by the first salvo.

d. The agent most likely to be used in chemical projector shell is phosgene. The explosive charge in these shell is only slightly greater than that necessary to rupture the shell body. The agent from a single shell is thrown over an area about 20 yards in diameter. The shell from a single battery or a group of batteries concentrated on a single point



FIGURE 2.—Installed chemical projector battery.

will scatter over an area about 320 yards in depth and 240 yards in width. The gas cloud will completely cover this area in 30 seconds. The prompt adjustment of the gas mask and the wearing of it until the gas moves out of the area fulfill the requirements for protection. The danger area also extends downwind in much the same way as explained in the case of nonpersistent agents projected by artillery or mortar shell. The danger area usually extends several thousand yards downwind from the impact zone.

e. Indications of the installation of projectors by an enemy may be obtained from airplane photographs. It should be noted, however, that projectors can be installed and fired in

one night. A projector attack can generally be recognized by a huge flash or a series of flashes immediately followed by a loud explosion. These shells make a peculiar whirring sound in flight and a subdued explosion when they burst.

f. If fired in daylight, chemical projector shell can be seen in the air. This projectile is usually fitted with a fuze burning about 20 seconds; if the loud explosion of the propelling charge is promptly recognized as a chemical projector attack, there is a period of about one-third of a minute in which to give the alarm and adjust gas masks before the gas begins to spread over the target area.

■ 11. **ATTACKS FROM AIRCRAFT.**—Aerial bombs may contain gases of varying persistency as well as smoke and incendiaries. Agents directly sprayed from aircraft are persistent gas or smoke. When flying at low altitudes, airplanes have the ability to launch surprise attacks on unsuspecting personnel. Smoke-laying airplanes can establish smoke screens permitting other aircraft equipped with bombs or spray apparatus containing chemical agents to reach their targets unobserved and protected against hostile fire.

a. Chemical bombs.—(1) The agents most likely to be projected by small bombs are mustard and white phosphorus. The explosion of the 30-pound bomb upon impact throws the agent over an area approximately 40 yards in diameter. The danger from chemical bombs of this size approximates that described in paragraph 9c for chemical shell.

(2) Aerial bombs of 100 pounds or larger may be used to discharge either persistent or nonpersistent gases. The action of agents thus released is similar in principle to the action of agents discharged from projector shell (par. 10) and necessitates corresponding protective measures.

b. Spray attacks.—(1) The agents most likely to be used for spray attacks are mustard, lewisite, and any type of liquid smoke. Attack aircraft flying between 50 and 1,000 feet can lay a belt of persistent gas in an effective concentration on the target. The actual length of the area covered will depend upon the capacity of the tanks used, their number, the rate of discharge, and the ground speed of the airplane. The actual width of the area covered will depend on the above factors, the altitude of the airplane, and the course of the

airplane in relation to wind direction. The belt will be wider when the airplane flies perpendicular to the wind direction than when it flies parallel to that direction. The average area covered by one attack airplane may be taken as 800 yards long and 300 yards wide. The drops will be larger on the upwind side, gradually getting smaller downwind across the target. Larger drops are more effective than smaller drops.

(2) The requirements for protection from a spray attack with vesicant agents include not only the prompt adjustment and wearing of the gas mask during the attack but also complete protection of the body from falling spray, which may be obtained by getting out of the path of the spray, by seeking cover therefrom, or by the wearing of protective clothing to exclude the agent from direct contact with the body.

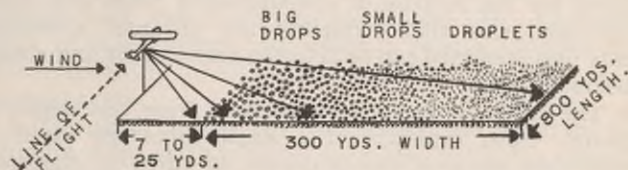

FIGURE 3.—Fall of liquid drops.

(3) After the attack it will be dangerous to occupy or cross the contaminated belt for a period varying from 10 hours to several days, depending upon the temperature and the quantity of liquid released. During this effective period, any person remaining in the area, or crossing it, is likely to become a casualty unless he wears a gas mask and complete protective clothing.

■ 12. CLOUD ATTACKS FROM CHEMICAL CYLINDERS OR CANDLES.—

a. Cloud attacks are dependent upon suitable wind direction. The characteristic features of a cloud attack are pervasiveness and duration. The liberated gas may affect an area extending several miles downwind, it being carried along the surface of the ground by the wind.

b. Gas clouds may be released from concealed cylinders or candles or from cylinders mounted on special vehicles.

c. The discharge may be made either by day or night. At the moment of discharge, some warning may be given by hissing of gas escaping from the cylinders. The cloud is normally white from condensed water vapor, but the actual location and width of the front may be disguised by the liberation of smoke. Only nonpersistent gas is used in cloud gas attacks, but this may remain for an hour in thick woods or even longer in dugouts or shelters. The gas most likely to be released from this weapon is phosgene.

■ 13. BULK CHEMICAL AGENTS AND CHEMICAL LAND MINES.—*a.* Chemical land mines, fired statically, may be effectively employed by the enemy in withdrawals and retreats for contaminating areas around destroyed bridges, fords, roads, trails, and in front of defensive positions. Persistent gas may also be liberated from containers carried by tanks or other vehicles for the purpose of contaminating roads and communication, and thus hindering the advance. Chemical agents thus employed can be detected only by odor and visible splashes.

b. The gas most likely to be released from this device is mustard. Upon explosion of a single mine the agent is thrown over an area approximately 40 yards in diameter. Areas contaminated by land mines should be avoided, if possible, or else passed on the upwind side. If it is necessary to penetrate the area, it should either be decontaminated as described in paragraph 25, or lanes cut through as described in paragraph 54*d*.

■ 14. CHEMICAL GRENADES.—Hand grenades filled with irritant gases are used to force personnel to evacuate dugouts and inclosed spaces. Phosphorus is also used in grenades, particularly as a casualty agent. Hand grenades can be thrown approximately 35 yards.

■ 15. EMPLOYMENT OF SMOKE IN CHEMICAL ATTACKS.—Smoke is sometimes used along with gas in order to deceive an opponent as to the location and extent of the gas. At times also, small amounts of tear gas may be released in a smoke cloud in order to force masking.

■ 16. GENERAL EFFECTS OF WEATHER AND TERRAIN ON CHEMICAL ATTACKS.—*a. Wind.*—(1) The effective use of chemical agents

is largely dependent on favorable weather conditions. Chemical agents are most effective in light winds; strong winds will rapidly dissipate them. Nonpersistent chemical agents are comparatively ineffective in a wind of over 12 miles per hour. Chemical agents of the highly persistent type are not affected to the same extent by strong wind.

(2) When the enemy releases a chemical agent for a cloud attack within his own lines, the wind direction must be from the enemy to our lines. The enemy may fire chemical shell, however, on targets within our lines when the wind is in any direction. If the wind is blowing toward his own lines, the quantity of agent used will probably be small and the target area a considerable distance from his own troops.

(3) When the enemy uses a large amount of mustard gas, it may be anticipated that the gas will be directed far enough rearward in the area attacked to prevent any of the vapor drifting back over his front-line troops. For this reason, when an enemy attacks, our troops in reserve are more likely to encounter the mustard type of agent than those in the forward areas.

b. Temperature.—(1) On warm sunny days, when the temperature of the earth is higher than that of the air, ascending air currents carry the gas upward and disperse it. Warm weather increases the rate of evaporation thereby reducing the persistency of the agent. Cold weather accompanied by clouds increases persistency.

(2) Substances like mustard gas may freeze in the soil. When mustard gas freezes, it is much less effective. However, the vaporization is still sufficient, except in subfreezing weather, to produce casualties if personnel are exposed for a considerable period. It must be kept in mind that solid particles of frozen mustard gas may become attached to clothing while passing through undergrowth and these particles will cause burns if they come in contact with the body.

c. Fog and rain.—Foggy and cloudy weather is favorable for the use of gas. Rainfall tends to wash gas out of the air and in most cases slowly destroys liquid on the ground.

d. Night.—The most favorable conditions for the use of gases, particularly those of the phosgene type, occur at night

or in the early morning, because strong winds and ascending currents are then usually absent. Furthermore, there is the possibility of effecting surprise on sleeping men.

e. Ground.—(1) *Surface.*—The most important effects of the ground on chemical agents in liquid form are as follows:

(a) Soft dry ground will absorb liquids and so reduce the danger from direct physical contact. It is difficult to detect vesicant gas, however, when absorbed in earth.

(b) On soft wet ground, gas may persist for considerable periods as free and unabsorbed liquid. Where shell or bombs burst on soft ground, a large proportion of the liquid content will be absorbed or buried in the crater, contaminating earth or mud. When boots or shoes become contaminated with liquid mustard gas and are later worn in inclosed places such as a billet or dugout, dangerous vapor concentrations may arise.

(c) On hard ground, the liquid contents of chemical projectiles are scattered over a relatively large area. Hard ground retards penetration of liquid agents released in this manner; consequently, the agents are exposed in greater degree to the influence of wind, sun, and rain, thus lessening their persistency, yet increasing the gas hazard.

(2) *Topographical features.*—All chemical agents successfully used in warfare are heavier than air. Unless set in motion by wind or air currents, gas clouds tend to flow into gullies and valleys, leaving the tops of hills comparatively free.

(3) *Vegetation and obstructions.*—Tall grass, bushes, trees, buildings, and similar obstructions retard the movement of the air and in like manner the movement of vapors of chemical agents, thereby making them more persistent. Tall grass and undergrowth increase the danger from vesicants.

■ 17. CONDITIONS FAVORABLE FOR CHEMICAL ATTACKS.—*a. Situations in which an enemy may use nonpersistent gas.*—(1) Between midnight and sunup, when ground temperature is lower than air temperature and troops are least alert.

(2) When wind velocities are between 3 and 12 miles per hour.

(3) When wind direction is either from the enemy or parallel to the front.

(4) On troops, particularly large concentrations, located in low ground or in woods.

(5) On foggy, overcast days.

b. Situations in which an enemy may use persistent gas.—

(1) Against strong points and centers of resistance which would be very difficult for the enemy to capture by assault and which he does not expect to occupy or pass through.

(2) In defiles.

(3) On terrain surrounding approaches to fords, bridges, and on beaches.

(4) On artillery firing positions.

(5) On distributing points, airdromes, bivouac areas, rail-heads, marching troops, and supply columns, especially by spraying from attack aviation.

(6) On a withdrawal by the enemy, he may be expected to leave bands of persistent vesicants in front of or within his former position and on routes that are likely to be used by pursuing forces.

(7) On important routes of approach.

c. Situations in which an enemy may use incendiaries.—

(1) Against villages of largely frame construction.

(2) Against army depots, airdromes, and large supply centers well to the rear where inflammable supplies, such as ammunition and forage, are stored in large quantities.

(3) Against position located in dry grain fields or woods, when the wind direction is from the enemy.

SECTION IV

PROTECTION AND PROTECTIVE EQUIPMENT

■ 18. CLASSIFICATION OF PROTECTIVE MEASURES.—Protection against gas attacks presents three classes of problems: individual, collective, and tactical. The first two involve protective measures of a generally passive nature; that is, principally the provision and use of protective equipment and installations. The third concerns modes of action and troop leading with a view to avoiding gas casualties in the conduct of military operations. These three forms of protection may be briefly outlined as follows:

a. Individual.—Individual protection includes not only the proper distribution, use, and care of protective equipment

but also ability to recognize the presence of a particular chemical agent; and, by knowing its characteristics, to utilize equipment in such a manner as to avoid becoming a casualty.

b. Collective.—Collective protection is the utilization of measures and unit protective equipment for the protection of personnel, animals, and matériel. It includes the posting of gas sentries, operation of gasproof shelters, measures to insure the preservation of animals and equipment, and the use and decontamination of protective covers.

c. Tactical.—Tactical protection includes such activities as chemical reconnaissance, chemical intelligence, selection of routes of march, camp sites, and battle positions; protective disposition of troops; schemes of deployment of units; maneuver to avoid gassed areas; and offensive action to forestall or disrupt the enemy's chemical operations.

■ 19. BASIS OF ISSUE OF PROTECTIVE EQUIPMENT.—Items of equipment for defense against gas attacks are issued in conformity with Tables of Basic Allowances.

■ 20. ARMY GAS MASK.—The gas mask protects the soldier's eyes and respiratory tract from chemical agents encountered in the field.

a. Principle of operation.—The principle of operation of the gas mask, which is based on air filtration, is illustrated in figure 4. Air is drawn into the mask when the soldier inhales, the mask being so constructed that this air must first pass through a canister containing a filtration system. This comprises a mechanical filter to prevent the entrance of smoke or dust, and a filler of charcoal and soda lime to adsorb and neutralize toxic and irritating gases and vapors. This air, after being purified by filtration, is drawn to the soldier's face, and, after being inhaled and exhaled, is expelled from the mask.

b. Types.—Two types of gas masks are issued, both of which operate as described in *a* above.

(1) The *service gas mask* as issued will give full protection against lung irritants, sternutators, and lacrimators in concentrations likely to be encountered in the field. It will *not* protect against carbon monoxide or ammonia gas, and is, therefore, not suitable for a fireman's mask or for use in case

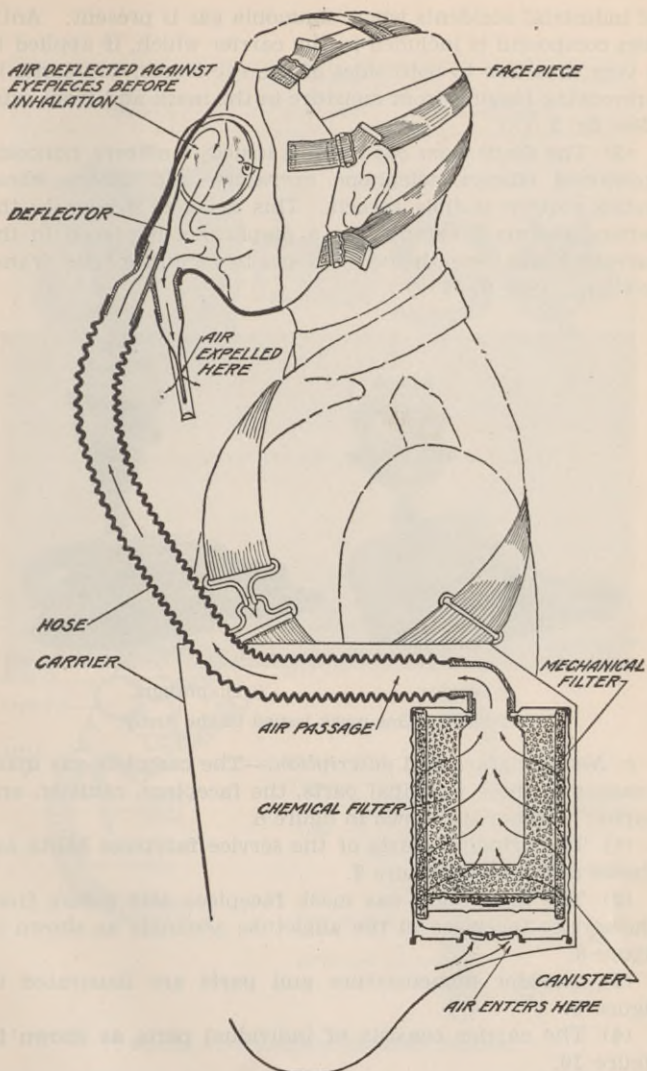
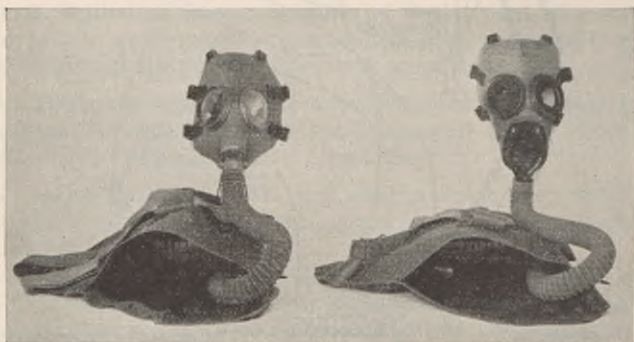

FIGURE 4.—Service gas mask showing passage of air.

of industrial accidents where ammonia gas is present. Antidim compound is included in the carrier which, if applied in a very thin film to both sides of the eye lenses, will assist in preventing fogging from moisture in the mask and from rain. (See fig. 5 ①.)

(2) The *diaphragm gas mask* is issued to officers, noncommissioned officers, telephone operators, and others whose duties require audible speech. This mask is similar to the service gas mask except that a diaphragm is placed in the facepiece just beneath the eyepieces to facilitate voice transmission. (See fig. 5 ②.)



① Service.

② Diaphragm.

FIGURE 5.—Gas mask issued to the Army.

c. Nomenclature and description.—The complete gas mask consists of three principal parts, the facepiece, canister, and carrier. These are shown in figure 6.

(1) The principal parts of the service facepiece MIA2 are shown and listed in figure 7.

(2) The diaphragm gas mask facepiece MII differs from the service facepiece in the angletube assembly as shown in figure 8.

(3) Canister nomenclature and parts are illustrated in figure 9.

(4) The carrier consists of individual parts as shown in figure 10.

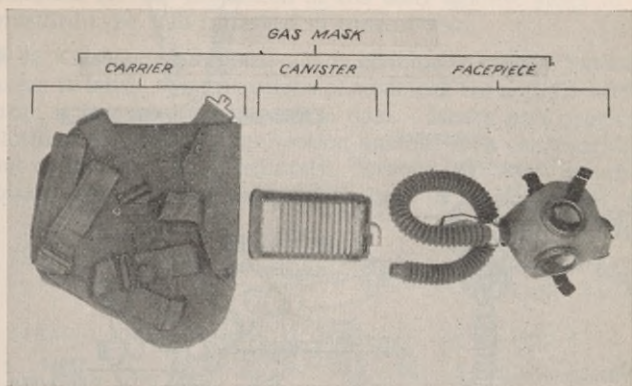

FIGURE 6.—Principal parts of service gas mask.

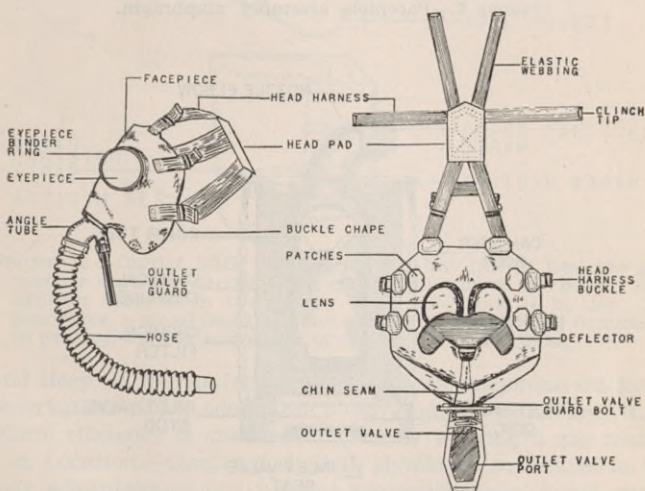

FIGURE 7.—Facepiece assembly, service.

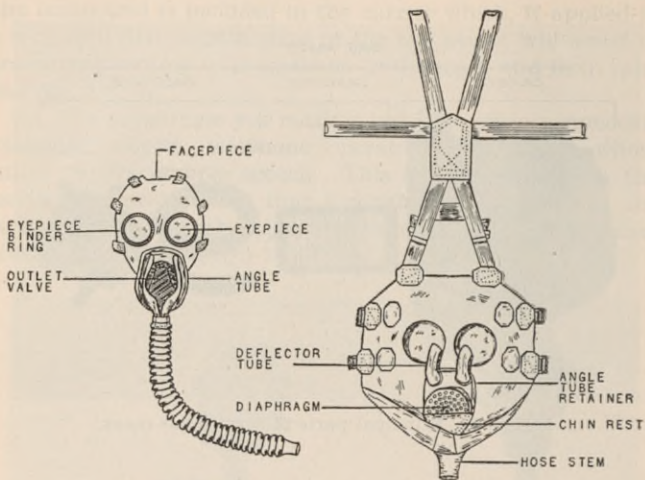

FIGURE 8.—Facepiece assembly, diaphragm.

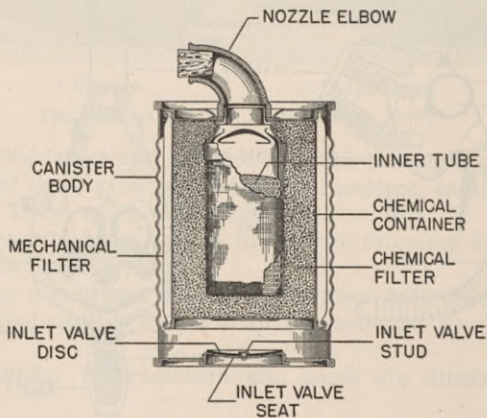

FIGURE 9.—Canister (sectionalized).

■ 21. PROTECTIVE CLOTHING.—Protective clothing, which is designed for the protection of the body against gases of the mustard type, will be issued in time of war.

■ 22. GASPROOF SHELTERS.—It is possible to subject extensive areas to lethal concentrations of toxic gas for periods varying from a few minutes to several days. Masks and protective clothing are sufficient protection against such concentrations but cannot be used indefinitely. Troops that must remain in gassed areas require gasproof shelters in which to rest, eat,

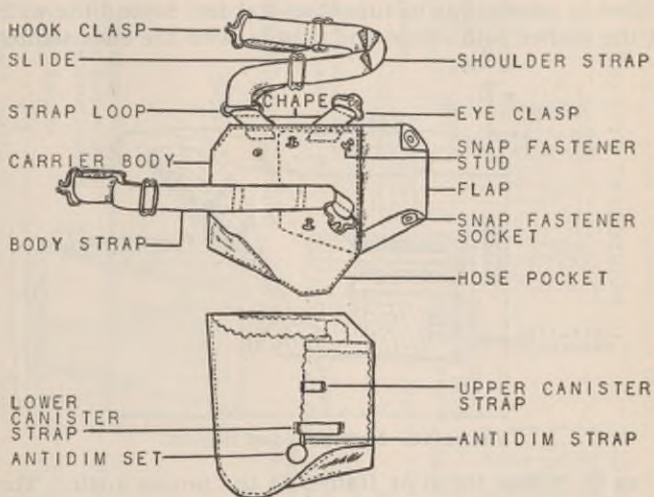

FIGURE 10.—Carrier MIII. (When carried but not in use, the gas mask is kept in a carrier slung on the left side of the body. The canister remains in the carrier when the mask is in use. In peacetime, a metal face form and a metal hose guard are furnished to prolong the life and shape of the facepiece and hose.)

and sleep, as well as for dressing stations, telephone stations, observation posts, command posts, and for other activities where efficiency is unduly impaired by wearing a gas mask.

a. Location.—Gasproof shelters should be so located as to take advantage of any natural protection from direct wind paths. Terrain has great effect upon the movement of a gas cloud, especially in a wind of low velocity. High hills and

deep valleys deflect gas from the general direction of the wind. Whenever possible, shelters should be located where heavy concentrations of gas will not form.

b. Principles of construction.—The important consideration in making a gasproof shelter is the elimination of all drafts. A special type of entrance is used which consists of a system of double doors of hung blankets which, when dropped, lie on slanting frames, the outer slanting outward and the inner slanting inward, forming an air lock. Whenever possible, the entrance to a gasproof shelter should be a walled-in passageway or tunnel several feet beyond the walls of the shelter both inside and outside, with the ends slanted

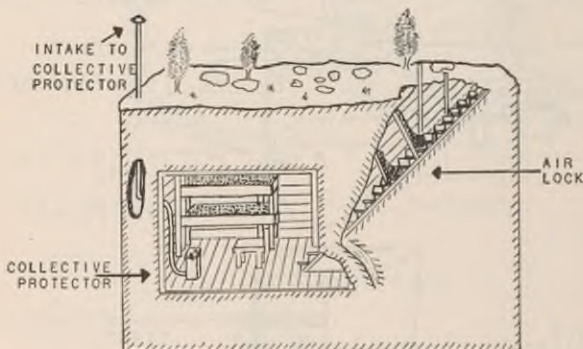

FIGURE 11.—Model of ideal dugout.

so as to receive the door frames at the proper angle. The door frame is made preferably from 1-inch by 6-inch boards at the sides and by 1-inch by 4-inch boards at the top and bottom. (See fig. 12.)

c. Construction of blanket doors.—Blanket doors are constructed by cutting a blanket to the proper size (about 4 inches wider and longer than the door frame) and attaching the top end to the door frame. Slats are nailed horizontally at intervals across the inside and outside of the blanket to hold it in place when lowered and to keep it pressed against the frame. The inside slats must be about 2 inches shorter than the width of the opening of the door frame. Either nails, nuts, bolts, or other special weights are used at inter-

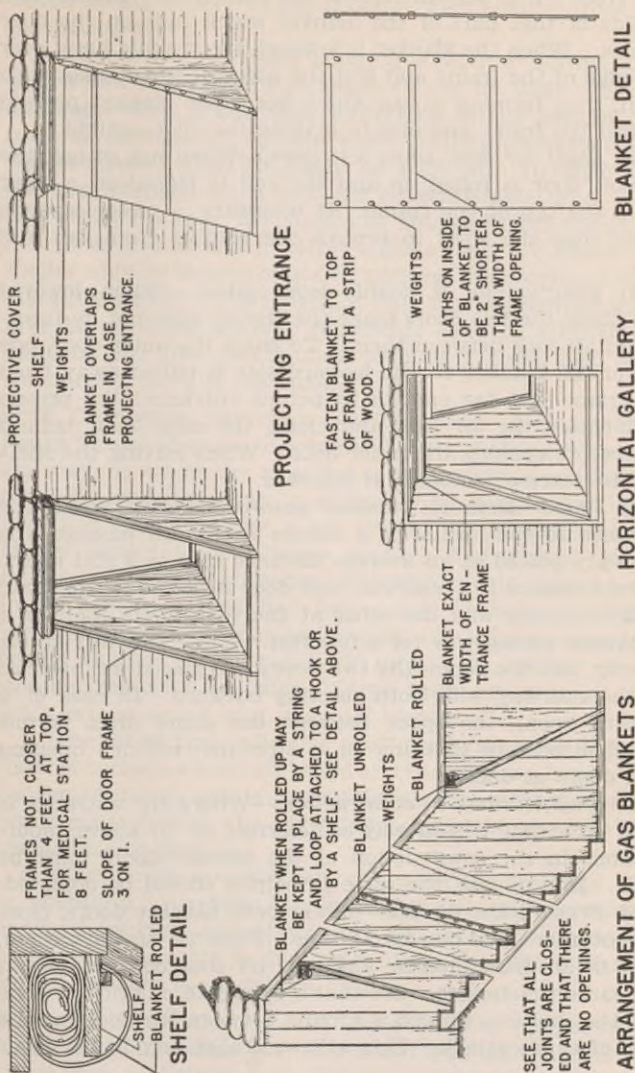

FIGURE 12.—Typical arrangement for gasproofing dugouts.

vals from top to bottom close to the edges of the blanket and outside of that part of the blanket which falls on the door frames. When the blanket is lowered, the weights hang over the edge of the frame and pull the edges of the blanket with them, thus forming a flap which keeps the blanket pressed against the frame and aids in making the door airtight.

(1) *Shelf for door when left open.*—When not in use, the blanket door is rolled up and the roll is placed on a shelf above the top of the frame. If necessary, a metal cover is nailed over the shelf to protect the blanket from sun and rain.

(2) *Functioning of double-door system.*—When lowered into place, the two doors make the shelter gasproof by forming an air lock between them. To enter the outer door, one side of the blanket on the leeward side is pulled away from the frame just far enough to permit entrance; the person then enters the air lock and closes the outer door behind him before opening the inner door. When leaving the shelter, the reverse procedure is followed.

(3) *Proper distance between gasproof doors.*—When the entrance to the shelter is a simple horizontal passage, the doors are placed at an average distance of 6 to 9 feet apart. If the entrance is a stairway, one door is placed at the head of the stairway and the other at the foot where there is a horizontal passageway for a few feet. If the stairway enters directly into the room, the two doors are placed at intervals on the stairway with both slanting outward. In case of a dressing room, the space between the doors must permit stretcher bearers to bring in a stretcher without opening both doors at once.

(4) *Modifications in construction.*—Where the entrance is not a projecting passageway as described in (3) above, modifications in the construction of the blanket doors must be made. In any case, the same principles should be observed.

(5) *Preparation for use.*—Lower both blanket doors, close all ventilators, and put out all fires. Fires use up the oxygen, draw in air from outside, and give off that odorless poison gas, carbon monoxide. See that a supply of chloride of lime is in the shelter. Spread it around between the doors at the start of a gas attack. This will neutralize any liquid agent

which might adhere to the shoes of men coming from contaminated areas.

d. Ventilation.—Persons entering a shelter during a gas attack will always bring in traces of gas on their shoes and clothing. This is especially dangerous in the case of mustard, as an effective concentration entirely imperceptible to the occupants may gradually be built up. In dugouts or shelters intended to be used for a considerable time, collective protectors (par. 23) should be obtained from the chemical officer and installed. After a gas attack, a contaminated shelter may be cleared of gas by opening the doors and building a fire within. The length of time that a gasproof shelter may be occupied without ventilation may be estimated by applying the rule that a man requires 1 cubic foot of air per minute; more is desirable.

■ 23. COLLECTIVE PROTECTOR.—*a.* This item of equipment is issued for use at gasproof command posts, plotting rooms, and aid stations, which are intended to be used for a considerable time and where air may, in a short time, become foul or deficient in oxygen during a gas attack. It consists of an air blower mounted on a large canister and several feet of flexible pipe. The collective protector should only be used in an inclosure that has been made reasonably airtight. When an old building is being used, the windows and large cracks should be chinked with mud, rags, paper, or any suitable material available. Large openings such as shell holes can be closed with gasproof blankets.

b. The latest type collective protector is set up outside the room or inclosure to be protected and the pipe run inside. The concentration of gas is invariably greater near the ground level; consequently, the air intake should be as high as is practicable to place it.

c. When a gas attack starts, the collective protector is set in operation. Air from the outside is pumped through the canister, purified, and blown into the inclosure. A positive pressure of pure air is thus built up in the protected space which prevents the entrance of gas.

■ 24. GAS ALARM DEVICES.—*a.* These items of equipment are issued to organizations. The standard type is the alarm horn which gives a distinctive sound not easily confused with other

sounds encountered in action. Empty shell cases or sections of iron rail may be used as improvised alarms when standard alarm horns are not available.

b. There are two classes of alarms given when an enemy gas attack occurs; general and local. General alarms are given only in the case of cloud gas attacks that are expected to involve a large area. Local alarms are given in all cases in which the presence of gas is recognized. A general alarm is sent out by all normal methods of communication and is

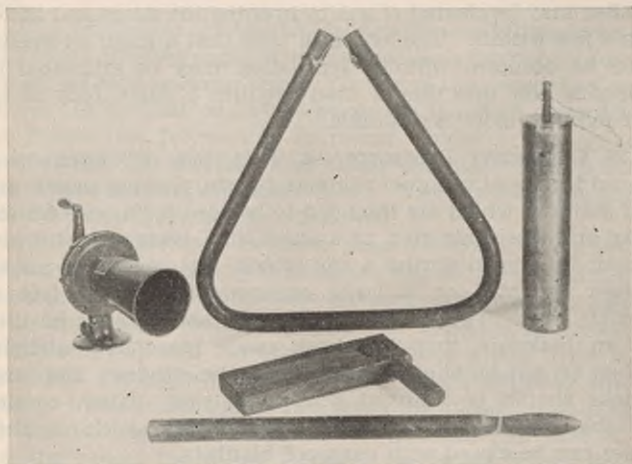

FIGURE 13.—Typical gas alarm devices.

directed to all localities that may be affected. Local alarms are usually given with alarm horns.

■ 25. DECONTAMINATION.—*a. Protection of degassing details.*—Men detailed for decontaminating work should wear gas masks and protective clothing. The entire body must be protected. The work should be performed under a noncommissioned officer. He should be prepared to apply first-aid measures in case of necessity, and should have the necessary solvents or neutralizing agents close at hand. The men should be inspected before commencing operations to insure that they are properly protected. Facilities away from other

troops should be provided for undressing and bathing after completion of their work. Men should be taught to assist each other in removing clothes used in decontaminating work without touching them to the bare skin or contaminating the clothing beneath. Facilities for disposal or cleaning of contaminated clothing should be provided. As decontaminating operations are local in character, their success will depend largely upon the equipment and facilities available.

b. Limitations.—Chemical agents may be destroyed or neutralized by other chemicals. No one chemical, however, is effective in all cases. Moreover, it is not practicable for an army to carry either a great variety or quantity of chemicals. Hence, decontaminating operations are necessarily limited. Whether they are practicable at all will depend upon the character of the chemical agent involved, extent of contamination, and importance of the contaminated area or equipment.

c. Marking contaminated areas.—When it is not practicable to decontaminate an area thoroughly, it should be marked with danger signs showing the agent involved and the date of contamination or its discovery. Generally, sentries should be posted to warn unauthorized persons against entering such areas.

d. When to decontaminate.—Decontamination work should be commenced immediately after the shelling or as soon thereafter as possible. It should be understood that when the shelling takes place at night or at other times when the temperature is relatively low, little vapor may be given off, while later, in the warmth of the sun, a high concentration may result. Areas treated during cool periods of the day should be inspected after the temperature has risen to determine whether further treatment is required.

e. Materials.—Decontaminating materials are issued in time of war to destroy or neutralize highly persistent agents of the mustard-gas type. Small areas, buildings, and equipment which have become contaminated can, within certain limits, be decontaminated. The following materials may be used for decontamination work:

(1) *Earth*.—Earth, sand, ashes, or sawdust may be spread over a contaminated area to give temporary protection. The covering layer should be at least 3 inches thick. This does not destroy the chemical agent but forms a seal preventing for a limited time the escape of toxic vapor. Such covering will be more effective if wet down with water.

(2) *Water*.—(a) Lewisite is readily decomposed by water, therefore liberal wetting of areas so contaminated is sufficient to destroy this agent. The reaction product of lewisite and water is a vesicant solid substance; while it gives off a little vapor, the solid causes severe burns on contact with the body. Consequently, even long after decontamination of a lewisite area, it is dangerous to sit or lie down in the area. After treatment with water, a lewisite area should, if practicable, be covered with a layer of earth, sand, or ashes.

(b) Mustard gas is very slowly hydrolyzed by water. The reaction product is nonvesicant. The action of cold water on mustard is so slow that it is practically negligible for decontaminating purposes. Hot water is more effective. However, where there is sufficient drainage, mustard gas will be washed away by water. As it is heavier than water, it will lie at the bottom of pools and puddles, remaining active for a long period of time, though the water over it will retard the escape of mustard vapor.

(3) *Bleaching powder (chloride of lime)*.—(a) This material is a white powder, not very stable, readily giving up its chlorine when exposed to the air or moisture. Consequently, it should be kept in airtight containers and used as soon as possible after removal therefrom. Bleaching powder reacts quickly with mustard gas, forming a nonvesicant compound. In contact with liquid mustard, it reacts violently not only causing flame but driving off a high concentration of mustard vapor. If the bleaching powder is mixed with sand or earth, this violent reaction does not occur. The proportion should be about one part of bleaching powder to three parts of sand or earth. One pound of bleaching powder is required per square yard of gassed area.

(b) In the decontamination of equipment, bleaching powder can frequently be more easily and efficiently applied in liquid form with rags or swabs. When used as a liquid solu-

tion, the proportion should be about one part of bleaching powder to one part of water.

(c) For decontamination of skin of animals or human beings, chloride of lime in proportion to one part powder to two parts of water may be used, but this slurry must be removed within 5 minutes after application, otherwise it may cause irritation to the skin.

(4) *Sodium sulphide*.—This chemical is used in a 1 per cent aqueous solution. It reacts more slowly than bleaching powder but, since no heat is evolved in the process, mustard vapor is not driven off. The solution is more effective if heated before use. It may be used either as a spray or mixed with sand. In the latter case, one part (by weight) of the liquid is used with four parts of sand and the mixture spread with shovels over the gassed area. Six gallons of sodium sulphide are needed for each square yard of area to be degassed.

(5) *Green solution*.—This solution which has a greenish color is prepared by dissolving 1 pound of bicarbonate of soda (baking soda) in 1 gallon of commercial hypochlorite solution. This mixture is less efficient for destruction of mustard gas than bleaching powder but is also less corrosive to metals, hence is applicable for decontaminating metal equipment. It should be generously used with sponge or rag until surface is cleaned.

(6) *Noncorrosive decontaminating agent*.—An additional material known as agent, decontamination, noncorrosive, is prepared by dissolving 1 pound of solid in 15 pounds of solvent. This agent is much less corrosive than any of the others mentioned. It is suitable for use on leather, cotton fabrics, instruments, and other items that might be damaged by the corrosive action of bleaching powder or other chemically active decontamination materials.

f. Methods.—(1) *Shell holes*.—(a) In demustardizing a shell hole, not only the shell crater but the entire area of contamination about the point of burst should be treated. A 75-mm mustard gas artillery shell produces a crater roughly 2 yards in diameter; however, the diameter of the area sufficiently contaminated with liquid agent to require decontamination is approximately 14 yards. With a 155-mm

shell the area is approximately 50 yards in diameter, and with the 4.2-inch chemical mortar shell it is approximately 40 yards in diameter. These areas do not center exactly on the shell hole but generally extend somewhat into the line of fire.

(b) Contamination is generally greatest in the shell hole itself. Pools of liquid mustard gas or large visible splashes on ground or vegetation are rarely found. In most cases mustard is only perceptible by its odor. The area outside the crater is usually much more lightly contaminated. If this area includes high grass or brush which cannot be decontaminated as it stands, it should be cut down so that it can be treated and disposed of. As a rule, 1 pound of bleaching powder for each square yard of contaminated ground is the minimum requirement.

(c) Sodium sulphide or green solution may be sprayed over a contaminated shell hole or first mixed with sand and spread with a shovel. Bleaching powder, however, is more effective for this purpose.

(2) *Grassland*.—An area covered with high dry grass or brush may be decontaminated by burning, provided this can be done without danger to nearby personnel. The heat will cause a heavy cloud of mustard vapor to be given off downwind during the burning. If burning is not feasible, bleaching powder mixed with water may be sprayed on small areas.

(3) *Weapons and metal equipment*.—Greasy or oily metal surfaces contaminated with mustard gas should first be cleaned with kerosene or gasoline. These solvents do not destroy mustard, but dissolve it so that most of it may be removed. Rags used for the purpose should be burned in a fire with a good draft, as they will be grossly contaminated. After such treatment, a very thin coating of mustard will still remain on the surface of the metal so that it will still be dangerous to touch. This is difficult to remove and must be treated with neutralizing chemicals. A solution of bleaching powder mixed with water, hot sodium sulphide, or green solution, are suitable materials to use, the latter two being much less corrosive. To avoid serious corrosion in using bleaching powder mixed with water, the application should not be left on for more than an hour at most. After such treatment the sur-

face should then be washed, dried, polished, and oiled. The noncorrosive decontaminating agent (par, 25e (6)) is the most satisfactory and effective for use on weapons and metal equipment.

(4) *Clothing and fabric equipment.*—(a) *Airing.*—Clothing contaminated by mustard vapor only may be decontaminated by hanging up the garments so that they will be exposed to the sun and wind. In warm bright weather, 2 days' airing generally will be sufficient. Care should be taken not to hang garments close together, especially not on top of each other. In cool cloudy weather, this method should not be relied upon.

(b) *Steaming.*—A more positive method of destroying mustard gas in clothing is to subject it to steam. If contaminated with mustard vapor only, clothing may be decontaminated by 2 hours of steaming. If splashed with liquid mustard, steaming should be continued from 4 to 6 hours. Various kinds of steam disinfectors can be improvised from materials available in the field. The simplest is merely a large G. I. can provided with a false bottom which serves to hold the clothing about a foot from the true bottom. Six or eight inches of water is poured into the bottom of the can, the false bottom inserted, and the garments piled in. The can is then placed over a fire, the top being covered but not so tightly as to prevent escape of steam. The capacity of such a disinfecter can be increased by hanging additional clothing in an inverted canvas bag suspended over the can, the open end of the bag being tied about the sides of the can.

(5) *Shoes.*—Little can be done in the field to decontaminate shoes permeated with mustard. If only lightly splashed and before the mustard has soaked into the leather, shoes may be neutralized by applying bleaching powder or bleaching powder mixed with water. As a safety precaution, it is well for men exposed to mustard gas to shuffle their feet from time to time through a mixture of bleaching powder and dry earth or sand. Well-worn shoe leather absorbs mustard much quicker than new leather.

(6) *Leather.*—Leather, unless specially treated, absorbs mustard almost instantly. Hence, equipment such as saddles and harness should be treated with a hot solution of bleaching powder and water immediately after being sprayed or splashed with this agent.

(7) *Buildings.*—In general, if liquid agents have been carried into buildings by shell fire, the buildings should be abandoned for military use in the field. If a building which has not been gas proofed has been subjected to vapors from vesicant agents, the ceilings and walls should be sponged or washed with a mixture of bleaching powder and hot water and the wooden floors should receive a thorough scrubbing with the same material.

■ 26. PROTECTION OF FOOD AND WATER SUPPLIES.—*a. Protective covers.*—Tarpaulins and vehicle covers made impervious to the persistent gases will be issued in time of war to protect transportation, equipment, and supplies.

b. Protection at the front.—(1) Rations and forage issued to troops at the front should insofar as practicable be kept in airtight containers until required for use.

(2) In stabilized situations and otherwise as circumstances may permit, gasproof shelters should be used for storage of food and water supplies in the field.

(3) Cooked rations sent to troops should be kept in closely covered containers until issued. Kitchens should be covered with paulins for protection against chemical spray. Tent flies or other overhead covers should invariably be provided for field kitchens. In case canned goods are sprayed with chemicals, the cans should be decontaminated by boiling before they are opened.

(4) Food and water not protected by containers, which have been contaminated by chemical agents, are normally discarded. In case there is a shortage of food, special instructions from a medical officer will govern as to its decontamination.

c. Contaminated water.—(1) Water contaminated with mustard should be avoided.

(2) Water contaminated by arsenical agents such as lewisite and adamsite, or by white phosphorus, cannot be purified and should be avoided.

■ 27. PROTECTION OF SUPPLIES, EQUIPMENT, AND MUNITIONS.—

a. Weapons.—(1) Field pieces, machine guns, rifles, and other steel weapons may actually be rendered useless by long exposure to the corrosive action of certain chemical agents. Unpainted working parts are especially vulnerable and as a

general precaution should be kept well coated with oil or grease. Weapons should invariably be inspected following gas attacks and, as soon thereafter as practicable, cleaned and reoiled. Gasoline will remove the old lubricant; water and soap, washing soda, or green solution should be used to clean the affected parts before new lubricant is applied.

(2) If sprayed with mustard gas, weapons must be decontaminated before it is safe to handle them. Bleaching powder mixed with water should be used on the wheels, trail, and outside of barrel of field pieces, but its use on breech locks, traversing screws, and other working parts of such weapons should be avoided because of its corrosive effect. Such parts should be treated as instruments. Alcohol or gasoline, hot water and soap, or other noncorrosive material as may be provided, such as referred to in paragraph 25e (6), should be used to remove the mustard. Wooden gunstocks contaminated with mustard should be treated repeatedly.

b. Ammunition.—Since brass shell and cartridge cases are particularly susceptible to corrosion by gases like phosgene, ammunition should be kept in sealed containers. If ammunition becomes badly corroded, it may be necessary to discard it or to clean it thoroughly before it is used.

c. Instruments.—Instruments such as those used in fire control should be kept in their containers except when in actual use. If exposed to corrosive gases, they should be cleaned with alcohol (or gasoline, if alcohol is not available) at the earliest opportunity, after which their moving parts should be given a thin coating of light machine oil.

d. Airplanes.—Vesicant spray attacks against airdromes are likely. Where it is not feasible to place airplanes in hangars, gasproof covers, at least for cockpits and machine guns, will be provided for placing over these parts when airplanes are not in use. Mustard sprayed on wings and fuselage of an airplane may do little if any harm; but if seats, instrument board, control, and firing apparatus are sprayed, pilots and observers later using the airplane may become casualties. Moreover, the decontamination of such parts will be extremely difficult. If an airplane becomes contaminated with a vesicant agent, it should be taken as soon as practicable to an airdrome where it can be properly decon-

taminated. Bleaching powder, hot water, and soap are used for this purpose.

e. Vehicles.—Drivers of vehicles which have been contaminated should be careful not to come in contact with contaminated parts in getting on or off a wagon or truck. Seat cushions which have been sprayed should be discarded. Washing thoroughly with water and using bleaching powder on badly contaminated spots is all that can be done in the field in decontaminating vehicles. Contaminated harness should be carefully cleaned before use.

f. Inflammable supplies and equipment.—Inflammable supplies and equipment should be piled in small stacks far enough apart to prevent one stack from catching fire from another in case the enemy uses incendiary agents.

SECTION V

THE GAS MASK

■ 28. DRILL.—*a. General.*—(1) Preliminary drills will be by the numbers in order to acquire completeness and accuracy in adjustment of the mask and to habituate the individual in its correct manipulation. Proficiency in this drill will be followed by training without the numbers to insure rapidity of adjustment. These drills are procedures designed to emphasize smooth, rapid, and accurate handling of the service or diaphragm gas mask and are not to be considered as precision or disciplinary drills. The movements should be executed AT EASE. As a rule, careful adjustment is more essential than great speed.

(2) Training in holding the breath will also be included. Holding the breath applies only to drill without the numbers. Its importance should be emphasized and men should be taught to hold their breath immediately upon detecting gas, or upon hearing the gas alarm or the command GAS.

(3) For detailed instruction, the commands described in *b* below will, where applicable, be preceded by the preliminary command BY THE NUMBERS.

b. Commands.—(1) *To sling the mask.*—The command is: 1. SLING, 2. MASK. At the command MASK, the carrier is held by the left hand near shoulder strap eye clasp, waist

high, in front of the body with side containing snap fasteners next to the body. The shoulder strap is straightened and held extended by the right hand (fig. 14).

TWO. Swing right arm to the left with shoulder strap passing around left elbow (fig. 15). Bring shoulder strap over right shoulder and couple hook clasp and eye clasp (fig. 16). Also, similarly fasten the body strap.

NOTE.—To sling carrier with full field equipment, sling the mask. Sling the pack. Unfasten left front pack suspender strap and pass it under carrier shoulder strap (fig. 17). Resnap suspender shoulder strap to its proper hole and fasten cartridge belt (fig. 18).



FIGURE 14.—Preparing to sling mask.

When for any reason except for display of equipment, equipment is removed, gas masks will be retained on the person. Remove equipment in reverse order.

(2) *To unsling the mask.*—The command is: 1. UNSLING. 2. MASK. Unfasten body strap. Grasp shoulder strap chape with left hand and using both hands, unfasten shoulder strap. Hold carrier with the left hand, waist high (fig. 19).

(3) *To adjust the mask.*—The carrier being slung, the command is: GAS. At the command GAS, dispose of arms, etc. Remove head covering with the right hand and at the same time open carrier flap with the left hand. Transfer



FIGURE 15.—SLING MASK. TWO. Passing shoulder strap around left elbow.



FIGURE 16.—SLING MASK. TWO. Fastening hook and eye clasps.



FIGURE 17.—Sling mask with full pack.



FIGURE 18.—Mask slung with full pack.



FIGURE 19.—Holding mask when not slung.



FIGURE 20.—GAS. Disposing of head covering (with chin strap).



FIGURE 21.—GAS. Disposing of head covering (without chin strap).



FIGURE 22.—GAS. Removing facepiece from carrier.

head covering to the left hand. Grasp facepiece with thumb and fingers of the right hand just above the angletube (fig. 22). Bring facepiece smartly out of the carrier to a point in front of the face, chin high. Grasp facepiece with both hands, thumbs inside and under the lower head harness straps, fingers extended outside of the facepiece, outer edges of palms together so as to form a pocket for the chin of the facepiece. (For details see fig. 23.) Thrust out the chin (fig. 24). (See notes 1, 2, and 3 below.)

TWO. Seat chin firmly in mask. Sweep head harness smoothly over the head without twisting elastic webbing straps (fig. 25), and center head pad well down on back of head (fig. 26).

THREE. Close outlet valve between thumb and fingers of the right hand and exhale vigorously so as to clear the mask (fig. 27). Seat edges of facepiece to the face beginning with palms of both hands at the chin and with an upward and backward sweeping motion press out all irregularities and channels (fig. 28). Recheck position of head harness. (See notes 4 and 5 below.)

FOUR. Replace headpiece. Fasten carrier flap over hose. Resume original position. (See notes 6, 7, and 8 below.)

NOTES.—1. Without the numbers, at the command gas. Stop breathing. Ability to hold the breath for 20 seconds or more under conditions of excitement should be developed.

2. Dismounted troops armed with or carrying weapons and equipment will immediately dispose of equipment and free both hands without permitting any part of the equipment to touch the ground. Mounted troops and animal drivers will halt and temporarily free both hands by disposing of the reins in such a manner as to prevent the mount or team from bolting.

3. After disposing of weapons during adjustment of the gas mask, pass head or chin strap of head covering over the left forearm (fig. 20). Soft cloth caps and headpieces without head or chin straps will be tucked in the waist or cartridge belt or between the carrier and the body (fig. 21).

4. To clear diaphragm mask MII, stop outlet valve using fingers of the right hand to press it flat against diaphragm retainer and exhale.

5. For adjustment without the numbers, resume normal breathing as soon as the mask is cleared and seated.

6. Headpieces having chin straps which can be unfastened will be placed under the chin and refastened, otherwise the chin or headstrap will be adjusted to the back of the head.

7. Weapons or equipment will be brought to the original position.

8. Mounted troops and drivers will dismount and adjust animal masks (par. 73).

(4) *To check fit of the mask* (notes 1 and 2 below).—The mask being adjusted, the command is: 1. CHECK. 2. MASK. At the command MASK, open carrier flap. Pinch

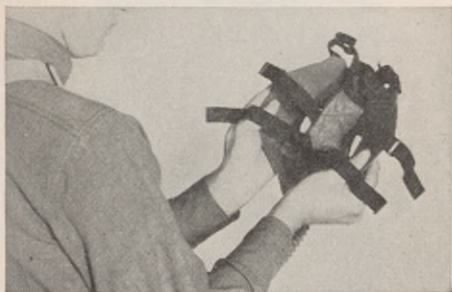

FIGURE 23.—GAS. How to hold the mask before adjustment to face.



FIGURE 24.—GAS. Ready to put on the mask.

together with walls of the hose near the canister. Exhale fully. Inhale. The facepiece should collapse against the face (fig. 29). (See note 3 below.) The outlet valve should



FIGURE 25.—GAS. TWO. Putting on the mask.



FIGURE 26.—GAS. TWO. Centering headpad.



FIGURE 27.—GAS. THREE. Clearing mask.



FIGURE 28.—GAS. THREE. Seating facepiece.

permit free escape of air. (See note 4 below.) If the mask checks, fasten carrier flap and resume normal breathing. (See note 5 below.)

NOTES.—1. The mask should be habitually checked each time after adjustment.

2. CHECK MASK is performed as a part of INSPECTION IN RANKS. (See par. 30.)

3. If the facepiece does not collapse against the face at this time and leakage of air into the mask is noted, two possible faults are indicated:

First.—If the leakage is noticed between the edges of the facepiece and the face, erroneous adjustment and fitting is probable. Such a fault may be overcome by pressing the edges of the face-



FIGURE 29.—1. CHECK, 2. MASK.

piece to the face and by carefully pulling up each of the opposing pairs of head harness straps a little at a time until the leak is stopped. Each of the opposing head harness straps must be tightened the same amount so as to keep the head pad centered. Tightening of the head harness must be carefully done because if it is adjusted too snugly, headaches and discomfort on prolonged wearing may result.

Second.—If adjustment of the head harness fails to stop the leak, it is possible that a hole or rip in the hose, outlet valve, or facepiece may have developed and a minute visual inspection of the gas mask as prescribed in paragraph 29 is necessary.

4. Outlet valve ports occasionally stick and cause exhaled air to pass out between the facepiece and the face, especially during very cold weather or after the mask has been disinfected. In case of a sticking outlet valve and with the mask adjusted to the face,

gently massage the valve ports with the thumb and fingers. If the valve still fails to operate, remove the mask and open the valve ports with a match stick but be careful that the valve is not injured or torn in so doing. Readjust the mask.

5. If visual mask inspection is to be performed, the carrier is not fastened.

(5) *To test for gas.*—The mask being adjusted, the command is: **TEST FOR GAS.** Take a moderately full breath,



FIGURE 30.—Test for gas.

exhale a portion of the air breathed, and stop breathing. Stoop so as to bring the face as close to the ground as possible without touching any part of the person or equipment other than the feet to the ground. Insert two fingers of the right hand between face and facepiece near the cheek so as to permit air to enter at that point. Sniff gently but do not inhale (fig. 30). Resume the erect position. Clear and re-

seat the mask as prescribed in the adjustment ((3) above). Resume normal breathing.

NOTES.—1. Personnel will be taught to test for gas habitually before removing the mask.

2. If mounted, dismount.

(6) *To remove the mask.*—With the mask adjusted, for detailed instruction to remove the mask, the command is: 1. REMOVE, 2. MASK. (See Notes 1 and 2 below.) Lift the headpiece with the left hand. Grasp the mask with the thumb and forefingers around the angletube with the right



FIGURE 31.—1. REMOVE, 2. MASK. Grasping facepiece in readiness to remove.

hand (fig. 31). Hold the mask away from the chin and lift it so as to slide head harness up over the head. Replace headpiece (fig. 32). (See note 3 below.) Hold facepiece in the right hand, chest high, with angletubes grasped by the fingers and thumbs with edges of facepiece to the left.

(7) *To replace the mask.*—For detailed instruction with the mask held as on completing REMOVE MASK, at the command 1. REPLACE, 2. MASK, open flap of carrier with left hand. Pull slack of hose out of carrier. With left hand,

fold head harness inside facepiece. With right hand, bring facepiece toward carrier. With left hand, loop hose over outlet valve guard and through facepiece, holding hose in this position with thumb and fingers of the right hand just below the eyepieces (fig. 33). Make sure that the hose is not kinked or stretched over outlet valve guard. Hold carrier flap open with left hand.

TWO. Rotate right wrist outward so as to bring the bottom of facepiece toward carrier. Insert facepiece, loop of hose first, into carrier (fig. 34), and rotate the wrist inward so as to bring the hose into circular pocket in bottom of carrier.



FIGURE 32.—1. REMOVE, 2. MASK. Replacing headpiece.

Check with both hands to see that hose and mask are fitted in the carrier without distortion or kinking. Refasten carrier.

(8) For purposes other than detailed instruction and inspection procedures, the commands prescribed under (6) and (7) above may be combined into a single command, 1. REMOVE AND REPLACE, 2. MASK. The procedure in such a case is continuous through the two commands with a distinct halt between.

NOTES.—1. Prepare head covering, if chin strap is snapped under chin or removed.



FIGURE 33.—1. REPLACE, 2. MASK. Looping hose.



FIGURE 34.—REPLACE MASK. TWO. Placing facepiece in carrier.

2. Arms and equipment will be placed in the most convenient way so as to free both hands while removing the mask. If possible, avoid grounding arms or equipment. On completion of the movement, retake arms and equipment.

3. With head coverings equipped with chin straps having means of unfastening, hang facepiece over left arm so as to free both hands while readjusting chin strap.

■ 29. VISUAL MASK INSPECTION.—The check of the mask as described in paragraph 28b (4), is not conclusive as to the serviceability of the gas mask. If during the execution of the command CHECK MASK, the facepiece fails to cling to the face and a leak is indicated, a minute visual inspection must be made. Visual inspections must also be made upon receipt



FIGURE 35.—INSPECT MASK. ONE. Examining canister.

of the masks and periodically thereafter for cleanliness and condition of the several parts of the gas mask. This inspection is made by the individual wearer. This inspection is not executed as a precision drill, but will be taught in the following manner:

a. Inspect mask.—Being at CHECK MASK, the command is: 1. INSPECT, 2. MASK.

ONE. Remove facepiece from face and hang it over left shoulder. Unfasten upper canister strap and remove canister. Examine canister (fig. 35). (See note 1 below.) Ex-

amine hose. (See note 2 below.) Replace canister in carrier, making sure that nozzle elbow points to the front (fig. 36) and that canister is correctly seated in the pocket formed by lower canister strap. Refasten upper canister strap.

TWO. Minutely and carefully examine the outlet valve (fig. 37), angletube assembly, facepiece (fig. 38), and head harness (fig. 39). (See notes 3, 4, 5, and 6 below.) Persons



FIGURE 36.—Placing canister in carrier.

with defective or faulty masks report to the instructor; all others replace masks as prescribed in **REPLACE, MASKS**.

Notes.—1. Serious defects in the canister are indicated by holes through the canister body, excessive rust and corrosion, and by loose or badly rattling contents. Rust or corrosion may be caused from water in the interior of the canister, this resulting in caked and damaged chemicals. Such a canister will be exchanged. Minor defects in the canister are faulty inlet valves and loose connections to the hose. These can be fixed in the organization.

2. Hose may develop holes, splits, and tears due to accident. These may be temporarily patched in an organization but should be replaced. Improper storage and incorrect placement of the hose in the carrier often causes kinks, undue stretching or tackiness, and permanent set of the rubber. Such hose should be replaced.

3. The outlet valve often develops pinholes and splits near the point of junction to the angletube. To find these, gently distend the rubber and examine closely for cracks. Outlet valve ports may become torn. If incorrectly stored, the rubber may become sticky



FIGURE 37.—INSPECT MASK. TWO. Examining outlet valve.



FIGURE 38.—INSPECT MASK. TWO. Examining facepiece.

or tacky and later hard and cracked with a permanent set. Defective valves will be replaced.

4. The chief defects occurring in angletubes are loose or missing outlet valve guard parts and insecure connections to the hose or facepiece. Any of these can be easily repaired.

5. Facepieces are affected by improper storage and careless use. The rubber may, unless correctly placed in the carrier, take a permanent set and form leakage channels around the edges. Head harness attachments may become torn or loosened. Cracks and splits sometimes develop near the eyepieces. Eye lenses sometimes are accidentally broken. Unless the damage is too great, facepieces usually can be repaired within the organization.

6. If head harnesses are adjusted too tight or with too great tension during drills and wearing exercises, the rubber threads of the



FIGURE 39.—INSPECT MASK. TWO. Examining head harness.

elastic straps may break. Improper storage may cause the rubber threads to deteriorate and lose elasticity. Badly defective head harness will be replaced.

b. To inspect carriers.—The mask being unslung (fig. 4) and held in the left hand as prescribed in (2) above, the command is: 1. INSPECT, 2. CARRIER. At the command CARRIER, open the flap. Visually examine the carrier outside to see that the straps, slides, eyeclasp and hook clasps, and snap fasteners are complete, the carrier body clean and in serviceable condition (fig. 40). Examine the interior to see

that the antidim is present and that canister straps and snap fastener are serviceable. Make sure that mask and hose are correctly placed in the carrier without distortion (fig. 41). Refasten flap.

NOTE.—Inspection of the carrier is habitually performed whenever the mask is to be laid away and not placed in company storage racks. The carrier may also be inspected at such other occasions as deemed necessary.

■ 30. INSPECTION IN RANKS.—*a. General.*—The individual is responsible for the gas mask and must see that it is in work-



FIGURE 40.—1. INSPECT, 2. CARRIER. Examining carrier.

ing order and ready at all times. A daily check and examination by the individual before the gas mask is to be used will be required. In addition, organization commanders will periodically inspect gas masks for condition and cleanliness and at the same time the individual will be required to demonstrate by test that his gas mask is correctly adjusted and gastight.

b. Formal inspection procedure.—Company commanders may inspect gas masks during any formal inspection ceremony and at such other formations as deemed necessary.

(1) *When field equipment is not displayed.*—The company commander commands: **PREPARE FOR MASK INSPECTION.** At the command **INSPECTION,** the company opens ranks as prescribed in drill regulations for the arm or service concerned. As the inspecting officer approaches each person, the mask is adjusted and checked by the man. The officer notes the fit and adjustment of the mask. The mask is then removed by the individual and handed to the inspecting officer who examines the cleanliness and condition of the face-

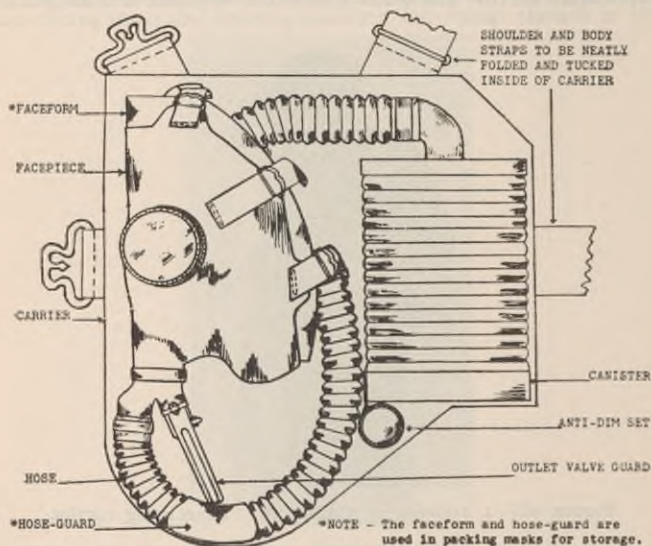

FIGURE 41.—Mask correctly placed in carrier.

piece assembly and, if desirable, causes the canister to be removed from the carrier for inspection. The mask is replaced in the carrier and the position in the carrier is checked by the inspecting officer.

(2) *When personal field equipment is displayed.*—Upon completion of the inspection of equipment as laid out, the company commander cautions, "Gas masks will be inspected." Platoon commanders command: **SLING CARRIER.** At this command, individuals sling the carrier. At the approach of

the company commander, platoon leaders proceed as indicated in (1) above.

(3) *Inspection of mounted organizations.*—Inspection of mounted organizations will include horse mask inspection in accordance with the procedure outlined in paragraph 75.

■ 31. ADJUSTMENT AND REMOVAL BEFORE, DURING, AND AFTER A CHEMICAL ATTACK.—Gas masks will be adjusted upon detecting the presence of gas, at the alarm of gas, or at the command of an officer or noncommissioned officer. They will be removed during or after a gas attack *only* at the command of an officer or a noncommissioned officer acting in command.

■ 32. FITTING.—*a. Facepiece.*—Facepieces which are too large may permit air to enter without passing through the canister. They may also cause the lenses to fall too high or too low with respect to the eyes of the wearer, thus restricting vision. The lenses should be in such position that the lower third of the upper half of each is directly over the pupil of the eye. Facepieces which are too small are uncomfortable and may also restrict vision. The procedure in fitting facepieces is as follows:

(1) *Estimation of size.*—Estimate size of mask to be worn by looking at the contour of the man's face.

(a) Gas masks may be issued in sizes from Nos. 1 to 5, inclusive, No. 1 being the smallest. Experience has shown that the percentages of different sizes required by average enlisted men are approximately as follows: Size No. 1, 4 percent; size No. 2, 50 percent; size No. 3, 35 percent; size No. 4, 10 percent; size No. 5, 1 percent.

(b) Universal size gas masks may be issued, in which case they will fit men who normally take sizes Nos. 2, 3, and 4, and some of the men who normally take size No. 1. If the universal size gas mask is issued, the percentages of sizes are approximately as follows: No. 1, 4 percent; universal size, 95 percent; No. 5, 1 percent.

(2) *Fitting.*—(a) When men are adjusting facepieces for the first time, the straps of the head harness should be loosened to their full extent. The gas masks are then put on and the head harness straps adjusted. The straps should be so adjusted that the head harness pad is well down on the

back of the head and the eyepieces are directly over the eyes. The fit of the facepiece to the contour of the face at the temples, cheeks, forehead, and chin should then be examined. The facepiece should fit snugly throughout.

(b) If a snug fit is not obtained, either a different size mask must be used or the head harness straps adjusted. In adjusting the head harness straps, it is important to see that the head harness straps on opposite sides of the face are adjusted to the same length. If it is necessary to shorten the head harness straps considerably, the facepiece is too large and the next smaller size should be used. On the other hand, if the facepiece, after the head harness has been properly adjusted, fits too far forward on the face or there is excessive pressure at the outer edge, the mask is too small.

(3) *Suction test.*—The simplest check on the fit of the mask is the suction test, which is as described under the command CHECK MASK in paragraph 28b(4). If the facepiece fits properly, it will cling to the face by vacuum and the wearer will be unable to get air. If the fit appears to be satisfactory as a result of this test, it should then be tested in the gas chamber.

(4) *Testing in gas.*—(a) Before any gas mask is used for protection against a lethal gas or irritant smoke, inspection of the mask will include a man test in a lacrimatory atmosphere to detect any leaks that may have resulted from improper assemblage or that have developed in storage from age or deterioration of components. A gas chamber is used for this purpose. The gas chamber consists of a room or other inclosure into which a chemical agent may be readily introduced and in which gas masks may be tested on the wearer. A lacrimator is used in a concentration which will cause only momentary discomfort if leaks or improper fits are encountered. The principal purposes which the chamber serves are as follows: First, it is a means of testing the fit and adjustment of the mask by exposure to a tear gas; second, it proves to the individual the fact that his mask really does protect him from gases and tends to dispel the fear of gas.

(b) Any reasonably airtight room or enclosed space of moderate size will serve as a gas chamber. For training in

time of emergency, the chamber should have adequate capacity. As a safety precaution, it should be from 100 to 200 yards away from any other place where personnel will likely congregate. It is desirable that the room be well lighted both naturally and artificially. A two-room building with each room approximately 25 feet square, of rough timber, covered with tar paper, and with two doors for each room, is large enough for a brigade. With nothing better available, a wall tent may be used. After a tent is used as a gas chamber, it should be turned wrong side out and left in the sun for several days before other use is made of it. Otherwise, subsequent users may be affected by the absorbed gases. The gas chamber is filled with an intolerable concentration of tear gas (chloracetophenone). The contents of one or two CN capsules or CN crystals (enough to cover a 25-cent piece) are placed on the top of a tin can, in the sides of which holes have been punched, and heated by a lighted candle placed underneath the can until the tear gas is volatilized. Before entering the gas chamber, the officer in charge puts the men through the gas mask drill and satisfies himself that all men are protected. Men wearing their masks are then sent into the chamber in groups of ten or more. A junior officer or sergeant takes station inside the chamber. The men stay in the chamber about 5 minutes. While there they talk and move around but do not tamper with the mask. On emerging from the gas chamber, the men move a sufficient distance therefrom to make sure that on removal of the mask the eyes will not be affected by fumes leaking from the chamber. They are examined by an officer in charge before they are allowed to take off the mask. He examines the fit of the mask, then orders the masks removed one at a time, and examines each wearer for signs of laceration. The man is asked whether the mask is comfortable. If the pressure on the man's face shown by the red outline is not well distributed or is extreme, the head harness must be loosened or a larger mask used. When the man has detected gas in the chamber, either the head harness must be tightened or a smaller mask used, in which case the test must be repeated in gas.

b. Adjusting shoulder sling to body.—In adjusting the shoulder sling to the body, the two shoulder sling slides should be so equalized that the stitched-in offset in the center of the shoulder sling will rest on the right shoulder.

c. Adjusting waist strap to body.—In adjusting the waist strap to the body, the strap can be lengthened or shortened by adjustment of the waist strap slide to fit the contour of the body.

■ 33. WEARING.—*a. In training.*—(1) Personnel should be given confidence in the protection offered by wearing the mask. This may be accomplished by having the individual properly masked enter a gas chamber in which a strong concentration of an irritant gas (CN) has been set up. After remaining in the gas chamber for a few minutes they are ordered to remove the mask and to remain in the chamber until lacrimation begins. Their confidence in the mask is thus built up by a practical demonstration of the protection afforded by it in an actual concentration of gas.

(2) On emerging from the gas chamber, the men should be instructed to face into the wind and blink the eyes to secure quick relief and under no circumstances to rub the eyes with the hands.

(3) Wearing the mask for long periods results in a noticeable reduction in the individual's efficiency. This loss in efficiency can be minimized, however, by practice in wearing the mask during general work. Just as marches fit men and animals to withstand campaign conditions, the wearing of the gas mask strengthens men's diaphragm muscles and reduces the fatigue of the wearer. The practice should be made easy at first and then progressively more difficult from day to day by varying the nature of the work performed as follows: Extended order exercises, firings at field targets, field maneuvers, and night marches. The night march over rough terrain is one of the most difficult things to do while wearing the mask but its accomplishment is most important for in actual warfare conditions the individual will often be required to function at night, either marching or on fatigue work, while wearing the mask.

(4) The foregoing applies particularly to dismounted troops. Mounted troops experience less difficulty in wearing

the mask. They should have practice in wearing the mask both mounted and dismounted.

(5) Training in wearing the mask should be conducted, when equipment is available, for at least 1 hour per week, and once each month the mask should be worn continuously for 1 hour. In the event of a mobilization, the troops should wear the gas mask continuously for at least 1 hour per day for the last week in the training area.

b. In operations.—(1) *Dismounted.*—Since dismounted men are subjected to considerable physical activity either on the march or in combat and the added breathing resistance of the gas mask reduces physical efficiency, unit commanders should require the wearing of the gas mask in combat operations only in case of necessity.

(2) *Mounted.*—Mounted organizations caught by gas in the early stages of the attack with weapons drawn may have to halt in order to adjust gas masks. The wearing of the gas mask does not seriously affect the efficiency of the mounted man; therefore, it may frequently be desirable to adjust masks prior to mounted action.

(3) *Motorized elements and mechanized units.*—(a) The operation of motor vehicles does not require hard physical exercise by the drivers and, since drivers are accustomed to wearing goggles, the wearing of the gas mask has very little effect on their efficiency. Drivers of motor vehicles should be required to mask whenever they are moving through an area in which there is a probability of encountering gas. Mechanized units should mask prior to the attack when they are likely to encounter gas.

(b) If the situation permits, moving motor vehicles encountering gas should be brought to a stop until all personnel has masked. No time should be lost in masking as agents of both the vesicant and lacrimator types affect the eyes. When the vehicle cannot be stopped, the operator should require his assistant to mask first and then take over the control of the vehicle while the driver masks.

■ 34. CARE.—*a. Responsibility.*—The gas mask is an expensive item of equipment. Its care both as an item for training purposes and as an article for the protection of the individual in war is very important. Extreme care will be

exercised by commanding officers to insure the extension of its useful life as much as possible. The primary responsibility for the care of the mask rest with the individual to whom it is issued; however, the unit commanding officer is responsible for the general supervision of the care exercised in the use, storage, and repair of all masks within the unit.

b. Causes of deterioration.—The chief causes of deterioration of the mask are age, prolonged dampness, heat, improper storage, rough usage, and neglect of minor repairs. The rubber parts of the mask gradually deteriorate with age through oxidation. Oxidation is much more rapid in the presence of moisture, heat, and sunlight. Prolonged exposure to moisture also causes the rotting of the stockinette fabric, the loosening of binding tape, the rusting of exposed metal parts, and sometimes mildew of the safety glass eyepieces. Improper storage frequently causes the collapse of the hose and a permanent set in the facepiece which destroys the fit. Rough usage may cause a break in the canister, a puncture of the hose or facepiece, or the breaking of the head harness and head harness attachments. The life of the mask can be greatly extended by careful use, by proper storage, and by frequent inspection and repair.

c. Inspection.—The visual inspection as specified in paragraph 29 is designed primarily to instruct the individual in testing the mechanical functioning and state of repair of the mask. The inspection by the company commander as prescribed in paragraph 30 is designed to provide for a periodic check of the care and condition of the gas mask, together with the training of the individual in gas mask drill. In cases where gas masks are held in a unit pool, such inspections as are necessary to ascertain the condition of gas masks will be made by unit gas officers. These inspections will include condition of storage, state of repair, and care of the mask exercised in field and training uses.

d. Repair.—Gas mask repair kits are issued which contain materials, implements, and instructions for minor repairs. The repair kit MII is intended for repairs of torn facepieces while the regimental repair kit MI contains all the materials and tools necessary for making repairs that are possible outside a gas mask factory. A complete description of these

kits and instructions for repair of gas masks are contained in TM 3-205 (now published as 1120-35).

e. Disinfection.—Whenever masks are exchanged or used by more than one individual for training purposes or otherwise, they should be disinfected immediately after use. The disinfection should be carried out as follows:

(1) *Materials required.*—A 2 percent solution of cresol or lysol. A supply of small rags.

(2) *Directions.*—(a) In disinfecting a gas mask, the facepiece should be kept lower than the canister to prevent the disinfectant from running into the hose and canister. Hold the mask in the hand, saturate a small piece of clean rag with the disinfectant, and sponge the entire surface of the facepiece, including the outer and inner side of the deflector. (In this operation the facepiece should not be turned inside out.) Then apply the disinfectant similarly to the outside of the outlet valve.

(b) Pour about a teaspoonful of the disinfectant into the exit passage of the angletube. Press the sides of the outlet valve with the thumb and finger so as to let the disinfectant run out. Do not shake off the excess.

(c) Allow all disinfected parts to remain moist for about 15 minutes and then wipe out the inside of the facepiece with a clean dry rag. The mask should dry thoroughly in the air before it is returned to the carrier.

f. Use of antidiim.—(1) *Purpose.*—Within the gas mask carrier, held in a loop, is a small can of antidiim. The purpose of this compound is to prevent fogging of the eyepieces.

(2) *How to apply.*—The eyepieces of the mask having first been cleaned, remove the stick of antidiim from its can and rub a little of the antidiim on both sides of the eyepieces applying the stick itself; then rub it evenly on the surface with the fingers. When this is done, polish both sides of the eyepieces with the cloth which is wrapped about the stick of antidiim until they are free of all foreign substances. If properly applied, the eyepieces will have a clear, even surface upon which blown breath will have no effect.

g. Care in training.—The gas mask is sufficiently rugged in construction to withstand ordinary usage. However, its life will be considerably shortened by improper care and use, and

also by using the carrier with gas mask in it for purposes other than those intended. Proper care in training requires the observance of the following rules:

(1) Keep the head harness just as loose as possible without losing the fit; the tendency is to keep it too tight, thus breaking the elastic or tearing off buckles and tabs. *Keep the harness extremely loose in the first drills for recruits.*

(2) Do not permit undue stretching of the head harness in putting on the mask. Require trainees to hold firmly to the facepiece until the face is well into the mask.

(3) Do not unnecessarily throw the mask around, or use the carrier as a seat or pillow, or as a receptacle for anything except components of the gas mask.

(4) Dry out the mask and carrier immediately after using and before repacking.

(5) Make repairs promptly when they become necessary.

h. Storage.—The following rules should be observed in the storage of the mask:

(1) Store in a cool, dry place.

(2) Do not store in sunlight or adjacent to steam radiators, stoves, or furnaces.

(3) Do not place in storage when either the mask or carrier is wet or damp.

(4) When the facepiece is in the carrier, keep the hose well rounded in the bottom of the carrier, thus preventing pressure on the tube by the outlet valve guard and subsequent collapse of the tube.

(5) Keep the face form in the facepiece, or in the absence of a face form, stuff the facepiece with newspapers. This prevents creasing of facepiece.

(6) Keep the mask where it will not be damaged by a blow or heavy weight.

(7) If the rubber in the facepiece becomes sticky in hot weather, sprinkle with talcum powder.

(8) If adhesive tape becomes loose, replace promptly before rust begins on binding wire.

(9) Repaint the canister whenever necessary to prevent rusting.

i. Garrison storage.—Gas masks issued to organizations in garrison should be placed in storage racks. These racks,

constructed as shown in figure 42, hold the masks in such manner that collapse of the hose or creasing of the facepiece is impossible. Construction plans for these racks may be found in TM 3-205 (now published as TR 1120-35).

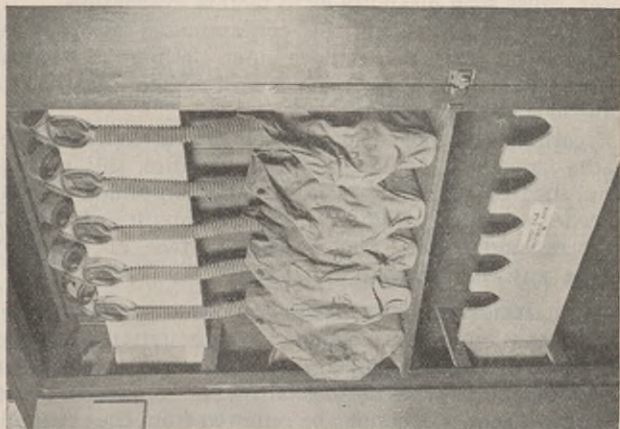
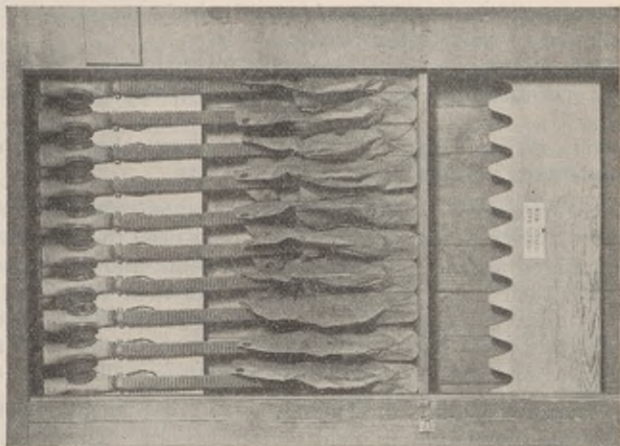

FIGURE 42.—Storage racks.

SECTION VI

FIRST AID FOR GAS CASUALTIES

■ 35. GENERAL.—*a.* The importance of first aid for gas casualties must be strongly emphasized. There are certain simple rules which all individuals must know. Unit commanders particularly must understand which gas casualties are allowed to walk to the rear.

b. Unit commanders are responsible for instruction in first aid for gas casualties the same as for casualties from other causes.

c. First-aid measures for the principal chemical agents are summarized in paragraphs 36 to 40, inclusive.

■ 36. LACRIMATORS.—Men who are lacrimated do not require evacuation as casualties. They only need to leave the contaminated atmosphere and face the wind, allowing it to blow into their eyes. They should not rub their eyes; their clothing and equipment should be loosened so as to get rid of entrapped gas. Bathing the eyes in cold water or with a weak boric acid or sodium bicarbonate solution will aid.

■ 37. IRRITANT SMOKES (STERNUTATORS).—These agents, such as DM, are not lethal in field concentrations. They may, however, cause such disability as to require evacuation.

a. Remove patient from the contaminated atmosphere, keep away from heat, and remove outer clothing. Flush the nose and throat with a weak solution of sodium bicarbonate (baking soda) or of ordinary salt.

b. Breathing chlorine in low concentrations tends to alleviate the irritation. In lieu of other facilities, this may be accomplished by breathing from a bottle containing bleaching powder (chloride of lime), or from a mixture of alcohol, chloroform, and ether. The exposed surface of the body should be washed with soap and water.

■ 38. LUNG IRRITANTS.—In order to reduce his oxygen requirements to the minimum possible, a lung irritant casualty should be made to lie down and not allowed to walk to an aid station even though he insists that he is able to do so. He should, as soon as possible, be removed from the contaminated atmosphere, his equipment removed, his clothing

loosened, and he should be kept warm. In addition to wrapping him in blankets, nonalcoholic stimulants such as hot coffee or tea should be given; and he should be evacuated as soon as possible as an absolute litter case.

■ 39. VESICANTS.—All agents classed as "vesicants" have also a powerful lung irritant action.

a. Mustard gas.—(1) The casualty should be immediately taken out of the contaminated atmosphere or area and his contaminated clothing removed. Should only portions of the clothing be splashed with liquid mustard, these can be cut away. If the face has been exposed, wash the eyes and rinse the nose and throat with a saturated boric acid, weak sodium bicarbonate, or common salt solution. If the vapor has been breathed, he should be treated and handled as a lung irritant casualty. First aid must be prompt for little can be done later than 20 to 30 minutes after exposure.

(2) Vapor burns on the skin may be lessened or even prevented by thorough cleansing with soap and water (preferably hot) immediately after exposure. Cleansing the exposed parts with gasoline (not containing lead tetraethyl) or kerosene prior to the use of soap and water will facilitate the removal of all traces of the gas.

(3) Mustard burns or skin areas wet with liquid mustard should be immediately and repeatedly swabbed with a solvent, such as kerosene, straight gasoline, any oil, alcohol, or carbon tetrachloride (pyrene).

(4) Fresh cloths should be used and the spreading of the contamination should be avoided. After cleansing with the solvent, the affected parts should be thoroughly washed with soap and hot water. Cloths used in removing the liquid mustard will be contaminated and should be burned or buried after use. A weak, freshly prepared solution of chloride of lime in water may be used in place of the oily solvent; this solution is itself very irritating to the skin and must, therefore, be removed by subsequent washing with soap and water.

(5) Fresh, uncontaminated clothing must be supplied where necessary. All casualties should be evacuated as soon as possible.

b. Lewisite.—(1) To be of any value against lewisite, first-aid measures must be instituted almost immediately. The treatment is similar to that for mustard.

(2) In lewisite burns, whether from vapor or liquid, the danger of poisoning from absorbed arsenic far overshadows the effect of the actual burn; it is, therefore, imperative to neutralize, if possible, any arsenic present and not yet absorbed. This may be accomplished by the immediate application of some hydrolyzing agent. A 5 percent aqueous solution of sodium hydroxide (caustic soda) has been found very efficient if applied soon enough. Following the hydroxide solution and cleansing with soap and water, liquid burns should be repeatedly swabbed with some oily solvent as suggested for mustard and again washed with soap and water.

(3) Following this, or in the absence of the hydroxide solution, vapor burns should be thoroughly cleansed with soap and water and then dressed with a ferric hydrate paste. The paste should be spread on thickly, covered with gauze, and allowed to remain for 24 hours.

(4) Fresh, uncontaminated clothing must be supplied where necessary. All casualties should be evacuated as soon as possible.

■ 40. INCENDIARIES.—*a.* For burns from incendiaries other than white phosphorus, treatment and handling are the same as for ordinary heat or fire burns.

b. (1) For phosphorus burns, immerse the affected part in water to stop the burning of the phosphorus and pick out the solid particles from the flesh. Wet cloths, mud, or damp earth may serve the purpose if immersion in water is not possible. As phosphorus melts at approximately 111° F., if hot water is used the melted particles may be removed with a cloth or sponge.

(2) The prompt application of an approximate 2 or 3 percent solution of copper sulphate in water will form a thin coating of copper phosphides on the phosphorus particles which will stop their burning at once. The coated particles can then be picked out from the flesh. The copper sulphate solution should be applied by soaking a pledget of cotton, a sponge, or a piece of cloth in the solution and then placing it on the phosphorus. A minute or two is sufficient time for

the formation of the metallic covering coat. After removal of the phosphorus, the burns should be dressed. All severe cases should be evacuated.

SECTION VII

ORGANIZATION AND DUTIES OF PERSONNEL

■ 41. ORGANIZATION FOR DEFENSE AGAINST CHEMICAL ATTACK.—Organization commanders are responsible for the proper training of their respective commands in defense against chemical attack and, within the means available to them, they are responsible for taking proper measures for the care and maintenance of protective equipment and for the protection of their troops, equipment, and supplies against gas. However, they have on their staffs specialists in defense against chemical warfare who advise them on the proper protective measures and who actively supervise the execution of all such measures under the authority of the commander. (See fig. 43.)

■ 42. DIVISION CHEMICAL OFFICER.—*a.* The division chemical officer is an officer of the Chemical Warfare Service assigned to the staff of the division commander. He is the adviser to the division commander on all matters pertaining to chemical warfare and has three specific functions: chemical warfare intelligence, training, and supply. Under direction of the division commander and in cooperation with the G-2 section of the general staff, he gathers information of enemy chemical warfare activities either through the brigade gas officers in "square" divisions or by direct means, transmits it to higher authority, and recommends to the division commander the issuance of such instructions to subordinate units as are necessary in each instance. He cooperates with the G-3 section in matters of chemical warfare training, recommends such procedure as is necessary in operations to insure defense against chemical attack, and exercises in the name of the commander a general supervision over all chemical defensive activities of the division.

b. It is a part of the duty of the division chemical officer to prepare a standing order for defense against chemical attack for his division. Such an order should be prepared

as soon as a newly mobilized division commences to function as such. These orders apply to all routine measures of individual and collective protection which are independent of the tactical situation. He determines whether or not gassed areas are fit for occupation; in the event they are not, he

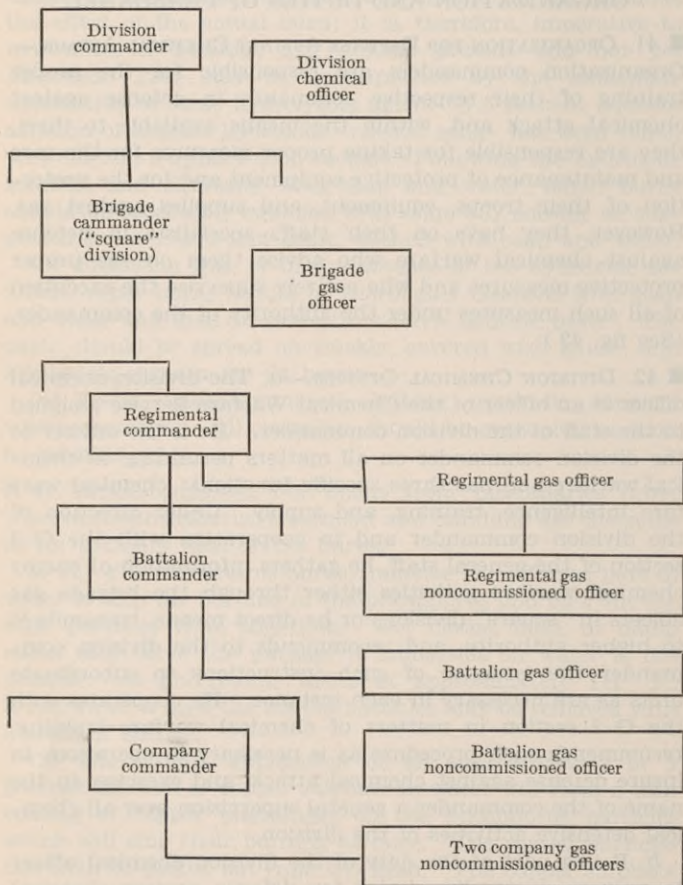

FIGURE 43.—Organization against chemical attack. (Regimental and battalion gas noncommissioned officers are in some cases organically assigned.)

posts them and warns the command of their location. The division chemical officer is the division supply officer for chemical warfare items of protective equipment. In this function, through the division G-4, he requisitions supplies from the army and issues them to regiments and separate units within the division.

■ 43. BRIGADE GAS OFFICER.—The brigade gas officer in the "square" division is an officer of the arm represented and is detailed by the brigade commander as brigade gas officer in addition to his other duties. The functions of the brigade gas officer within the brigade are of the same general nature as those of the chemical officers of higher units.

■ 44. REGIMENTAL AND BATTALION GAS OFFICERS.—*a.* Each regiment and battalion will have at all times one gas officer and one gas noncommissioned officer who are qualified instructors, and each company will have two gas noncommissioned officers. These officers and noncommissioned officers are members of the arm or service represented and are detailed by, and unless otherwise directed, submit all reports to their respective commanders. The work performed by these gas officers differs from that of the division chemical officer in that it is mainly limited to protection against chemical attack. The division of duties between the regimental and battalion gas officers is on the basis of the unit or command of which the officer is a part. In some situations, their duties may be so closely related that those performed by the regimental gas officer and the battalion gas officers will overlap.

b. The regimental gas officer will exercise general supervision over the battalions in training for defense against chemical attack, care and issue of protective supplies, and in the work of chemical intelligence and protection before, during, and after a gas attack.

c. The most important of the duties performed by these officers are as follows:

(1) Report all gas shelling promptly, giving time, location, weather, wind; number, size, and kind of shell used; and casualties. Any mustard-gas shelling in the unit area should be reported immediately.

(2) Report promptly all changes in gas personnel.

(3) Report name, grade, and organization of all personnel violating standing orders for protection against chemical attack.

(4) Report the condition of gas masks in the hands of troops as indicated by frequent inspections.

(5) Make sure by frequent inspections and tests that alarms in the unit area are adequate and in working order.

(6) Advise lower unit commanders as to the requirements for gas sentries and report to his commanding officer the adequacy of sentries posted as determined by inspections.

(7) Make such inspections as may be required to insure that gas sentries know where all sleeping men in their area are located.

(8) Inspect all gas noncommissioned officers frequently, reporting those by name, grade, and organization who are considered incapable.

(9) Make sure that adequate protective measures are taken for attached units or personnel.

(10) Submit a brief report each week covering the work done during the week as gas officer. This includes the nature of all duties performed and the amount of time required therefor.

d. The regimental gas officer assures himself by inspections that the regiment has a sufficient supply of protective equipment and matériel and that they are in good condition.

e. When the division first goes into action, the battalion gas officer must immediately familiarize himself with the topography of the area in which the battalion is to operate. Based on this knowledge, he makes recommendations as to the safety and suitability, from a chemical warfare point of view, of the places that are to be occupied by the different elements of the battalion and in conformity therewith prepares the battalion plan of protection.

f. He carefully observes the meteorological conditions when troops are in contact with an enemy and warns troop commanders when conditions are favorable for an enemy attack.

g. During an actual chemical attack, the battalion gas officer observes and assists in the enforcement of gas discipline. He advises his commanding officer and subordinate commanders of the battalion on proper gas defensive action and

obtains all possible information of the attack that may be of value in preparing plans of protection for subsequent attacks.

h. After the gas attack, he makes appropriate recommendations to his unit commander to correct deficiencies noted during the attack and prepares such plans as may be necessary to meet subsequent attacks. At the direction of the unit commander, he takes appropriate action to remedy deficiencies in gas defense in subordinate elements of the battalion.

i. The general problems of gas defense for unit gas officers of artillery units are not so difficult as in infantry units due to greater ease of communication and simplicity in the problems of evacuation. The artillery troops themselves, however, have a disadvantage in that they are more likely to be shelled by large caliber guns containing large amounts of chemical agents. Also, after a chemical attack, there is the problem of cleaning, oiling, and caring for the artillery equipment which has been exposed to the action of gas.

j. It is the duty of regimental and battalion gas officers to see that provision is made for the gas defense of any attached units operating within their organization area.

■ 45. COMPANY GAS NONCOMMISSIONED OFFICERS.—The company gas noncommissioned officers are appointed by the company commander. They assist the company commander in all matters pertaining to defense against chemical attack. Under direction of the company commander they have three specific functions: chemical intelligence, instructions and inspections, and supply and repair. Acting under the direction of the company commander, they are charged with identification of enemy chemical agents and the detection and posting of gassed areas. They assist the battalion gas officer when in the company area in obtaining specific chemical information. They assist the company and platoon commanders in inspecting the fit and state of repair of masks and act as assistant instructors in gas mask drill and identification of agents. They make frequent inspections of gas sentries and instruct them in their duties; inspect the alarm system, gasproof shelters, protection of food and water; and warn the company commander when terrain and weather

conditions are favorable for enemy gas attacks. They supervise the decontamination of small important localities. One supervises maintenance for chemical warfare items of protective equipment.

■ 46. GARRISON ORGANIZATION.—*a.* An officer of one of the arms, of rank commensurate with the duties involved, will, at those posts where an officer of the Chemical Warfare Service is not on duty, be detailed as post gas officer on the staff of the commanding officer. This officer will supervise the training in chemical warfare of all units at his post and perform the duties prescribed by AR 35-6520 insofar as chemical warfare supplies and ammunition are concerned.

b. On regimental and battalion posts, the post gas officer may be the regimental or battalion gas officer. On larger posts, a senior officer normally is detailed. The post gas officer, as an assistant to the training officer, in turn coordinates the training schedules of the units in chemical warfare. He provides for the issue of the pooled gas masks in conformity therewith and makes recommendations for the use of the allowances of chemical warfare training munitions.

■ 47. GAS SENTRIES AND THEIR DUTIES.—*a.* The duties of a gas sentry are to—

(1) Enforce all specific orders of his post for defense against chemical attack.

(2) Locate the position of all sleeping men in his area.

(3) Detect the presence of chemical agents by odor, color, and state.

(4) Give the alarm whenever gas is detected.

(5) Detect sounds indicating the preparation for and actual enemy projection of chemical agents.

(6) Protect supplies in his area.

b. In the event of a gas attack, the gas sentry will adjust his mask, sound the alarm, and immediately proceed to wake up every man in his area. The gas sentry will not pass on alarms arising in other areas but will give the alarm only when he himself detects the presence of gas. This precaution is necessary in order to prevent the spreading of false alarms. Standing orders of all units will prescribe the duties of the gas sentry in cases of general gas alarms, and

it is the duty of all officers in charge of such sentries to insure that they understand these instructions.

c. In addition to their other duties, all sentries will give the alarm whenever they detect the presence of gas. The gas sentry, always on the alert to detect the presence of gas, provides security to the other men of the command and permits them to gain much-needed sleep and rest. This is his most important function. Provision must be made for posting an adequate number of gas sentries over sleeping troops and working parties in the theater of operations to



FIGURE 44.—Gas sentry in World War.

insure that every sleeping man shall be awakened and every man engaged in work warned in time. Each gas sentry should be equipped with a gas alarm, should have a definite area to alarm, and should know when to give the alarm.

d. A gas sentry is always posted at a gasproof shelter and takes post on the upwind side. In the event of a gas attack, he performs the following duties:

- (1) Adjusts his mask and sounds the alarm to warn occupants of the shelter to close inner door or lower blanket.
- (2) Closes outer door or lowers blanket.

- (3) Looks after proper entrance and exit of personnel.
- (4) Assures the airtight adjustment of outer door or blanket.
- (5) Requires all degassing measures of personnel before entering.
- (6) Observes that number of entrants does not exceed prescribed capacity of a nonventilated shelter.
- (7) Directs starting and operation of collective protector at a ventilated shelter.
- (8) Opens door or raises blanket for litter bearers at an aid station.
- (9) Tests for gas and advises occupants of a shelter when it may be opened after a gas attack.
- (10) After a gas attack, directs that air lock, and shelter if necessary, be cleared of any gas that may have entered.
- (11) Resumes his post promptly.

■ 48. SPECIAL GAS SENTRIES.—These sentries are usually posted to guard dangerous gassed areas or supplies at distributing points. Their duties do not differ from the usual gas sentry except that they are given special instructions regarding special duties. Special gas sentries on duty where supplies are stored should have protective clothing and masks. Such installations will be chiefly the targets of enemy attack employing vesicant spraying devices. The primary duty of these sentries is to protect the supplies. Since such an air attack develops very fast, the gas sentry has only a few seconds to pull the protective covers into position. He should, therefore, be in a state of readiness to act at an instant's notice. In case the enemy air attack includes incendiary bombs, he will give the prescribed fire alarms.

■ 49. STANDING ORDERS FOR DEFENSE AGAINST CHEMICAL ATTACK.—*a. Definition.*—Standing orders for defense against chemical attack are general orders issued by each army, corps, division, or smaller force, if acting independently, which set forth definite and uniform procedure in the protection of the command against gas. The contents of these orders will vary in different commands and in different

situations. They will usually contain instructions on the following:

(1) Designation of zones or areas within which special precautions against gas attacks will be taken.

(2) Special precautions that will be taken in the designated zone; gas reconnaissance; cover, general care, and use of protective supplies; care of food, water, equipment, etc.

(3) Directions for inspection of units to determine status of training in defense against gas and the condition of protective supplies and equipment.

(4) Distribution and general instructions for employment of gas alarms.

(5) Requirements for gas sentries and general instructions for their employment.

(6) Procedure during and after a gas attack, both individual and unit; the gas alarm; when to put on and take off the gas mask; care of supplies and equipment; action of the unit as a whole.

(7) Use of gasproof shelters when they are provided.

(8) General instructions for handling gas casualties.

(9) Action to be taken by units and individuals to avoid areas contaminated with persistent gas; marking of such areas and guards therefor.

(10) Decontamination operations that will be undertaken and by whom performed.

(11) Reports to be made of gas attacks; when, by whom, to whom, and scope.

(12) Directions on preparation of plans of protection; when and by whom submitted.

b. Time of publishing.—When possible, standing orders are published in sufficient time before entry of a unit into the theater of operations to permit the command to become thoroughly familiar with them. Standing orders for defense against chemical attack should be learned thoroughly.

c. Form.—For suggested form for a standing order for defense against gas see Appendix.

SECTION VIII

TACTICAL PROTECTION

■ 50. DEFINITION AND SCOPE.—*a.* "Tactical protection" is the term used to designate disposition of troops in combat and security measures taken to avoid or greatly reduce the number and severity of gas casualties and to minimize the chances of contamination of supplies and equipment.

b. Tactical protection therefore includes such activities as chemical reconnaissance; chemical intelligence; selection of routes of march, camp sites, bivouac areas, and battle positions least favorable to enemy gas attacks; alternate routes, positions, and areas; maneuver to avoid gassed areas; schemes of deployment of units to minimize the effects of gas attacks; and offensive action to forestall or disrupt the enemy's chemical warfare operations.

■ 51. CHEMICAL RECONNAISSANCE AND INTELLIGENCE.—*a.* *Chemical reconnaissance.*—(1) *Distant reconnaissance.*—Distant chemical reconnaissance is conducted by observers in airplanes and highly mobile ground forces such as horse or mechanized cavalry.

(*a*) *Airplanes.*—Distant reconnaissance by airplane provides accurate information of the terrain. Aerial photographs, both vertical and oblique, show the location of wooded depressions, stream beds lined with underbrush, deep defiles, ravines, etc., which, if contaminated by chemicals, would be serious obstacles to advancing troops. This reconnaissance may provide specific information such as enemy activities indicating installation of chemical mines, cylinders, projectors, etc.

(*b*) *Mobile ground forces.*—Distant reconnaissance by mobile ground forces should determine the enemy's immediate preparedness for chemical operations, both offensive and defensive. It will be ascertained by observation, raids, questioning of prisoners and inhabitants, and all other means of obtaining information.

(2) *Close reconnaissance.*—Chemical reconnaissance becomes more detailed as opposing forces draw closer together, particular attention being paid to the terrain with a view to selecting halting points, camp sites, routes of approach, and

battle positions which are less favorable to enemy gas attacks. Airplane observation and photographs and ground reconnaissance by cavalry are of value in this phase in developing specific chemical information. Each unit of the main body, however, must reconnoiter on its own front and flanks with a view to selecting routes of approach and alternate routes to be used in case gassed areas are encountered.

(a) *Reconnoitering gassed areas.*—The following information is secured by such reconnaissance: Location and extent of the area; kind of gas and concentration, heavy, medium, or low; availability of routes for troops and vehicles for avoiding the area by passing it upwind; availability of routes for passage downwind, determining whether wearing of gas masks will be necessary; feasibility of preparing a roadway or using some established road or path through the area.

1. Low-lying patches of woods, defiles, ravines, and stream beds covered with high grass or underbrush are types of areas that are favorable for gassing with persistent vesicant agents. In situations where there is any likelihood that the enemy is using persistent gas, all such areas should be carefully reconnoitered.
2. Persistent gas having been detected and its character determined, the reconnoitering party, with gas masks adjusted, determines the extent of the gassed area. Some members of the party proceed upwind to determine the upwind edge of the area and possibilities of passage of the area on that side. From time to time they halt and test for gas. They do this as sparingly as possible. In the case of mustard gas, testing for gas every minute or two for 20 or 30 minutes would probably cause severe eye irritation, even though each exposure were exceedingly brief. Moreover, sensitivity to the odor of mustard gas is deadened by continued exposure.
3. Meanwhile, one or more of the reconnaissance detail is making a similar inspection on the downwind side.

4. After the extent of the area has been determined, it must be marked with gas danger signs showing the kind of gas and the date of the contamination or its discovery. Other units approaching from the rear should be notified and, if necessary, a sentry posted at the entrance to the area to give warning. Whether it will be necessary to pass through the area in the reconnaissance depends upon its size and whether routes for passing it to one side or the other are available.

(b) *Importance of daytime reconnaissance.*—It is extremely difficult for reconnaissance to be made of gassed areas at night. When practicable, close inspection of the terrain must be made in the daytime in advance of the march, thus avoiding the possible surprise encounters of such areas. However, if a gassed area is encountered unexpectedly by an advancing unit, it is essential that the reconnaissance be made quickly and decision made as to passage of the area, whether around or through it.

(3) *Battle reconnaissance.*—Gas reconnaissance in battle will include the securing and disseminating of information on the enemy's actual and potential gas activities. After the gas attack has been made it will include the location of gas-free areas for use by troops and the obtaining of information on which to base recommendations for the evacuation of areas rendered untenable with persistent gas.

b. *Important factors in chemical combat intelligence.*—(1) Chemical intelligence is in general derived through the same means and as a part of general combat intelligence; that is, reconnaissance and observation. It deals directly with information of chemical activities, intentions, equipment, munitions, and training of the enemy forces in the field, and is handled through the regular intelligence agencies in the same manner as any other information of the enemy.

(2) Information from any source obtained by unit commanders is the basis for planning chemical security for the unit and, with such interpretive comment as they may make, is turned over to the intelligence officer of the unit to be included in his reports to higher headquarters. Thus chemical

combat intelligence is coordinated and becomes of general information for the entire Army.

(3) The following factors of chemical combat intelligence are the most important to be considered:

(a) Observation and consideration of local weather conditions; that is, whether favorable or unfavorable for enemy gas attacks of any kind.

(b) Probable intention of the enemy with respect to employment of chemical agents as indicated by his armament and activities.

(c) Location and disposition of the enemy.

(d) Location of terrain features which are likely to be traversed or occupied by our own troops and which are good target areas for gas.

(e) Location of enemy emplacements or installations for projection of gas.

(f) Character and amount of enemy chemical weapons and ammunition with special regard to any new developments.

(g) State of enemy gas discipline, training, and protective equipment.

(h) With respect to any particular gas attack, the amount and kind of chemical agent used; method of attack; number of projectiles fired; caliber, marking, and distinctive features of gas projectiles; location of areas affected; date, if contaminated with a persistent agent; casualties resulting; and any other pertinent data.

(i) Location and extent of contaminated areas.

(j) Interpretation of the enemy's chemical tactics; that is, what they may indicate as to his subsequent intentions.

(k) Information relative to our own use of gas, state of protective equipment of our own troops including gasproof shelters, and available protection of equipment, food, water, and general supplies.

■ 52. DISPOSITION OF TROOPS TO MEET A CHEMICAL ATTACK.—*a. Effect of weather and terrain on chemical attack.*—Conditions which favor an enemy gas attack and which a unit commander must take into consideration are covered in paragraph 17.

b. Selection of favorable localities.—(1) Defiles, ravines, and depressions are very likely to be heavily gassed by the

enemy to hamper and delay the advance of the opposing force. Occupation of these areas should be avoided and in no case entered before a gas reconnaissance is made. Wooded areas or those covered by heavy underbrush should be thoroughly reconnoitered before entering.

(2) As a rule, the terrain features which afford the most cover from rifle fire and shells are those which contribute most to the effectiveness of gas. The gas problem may sometimes be the lesser of the two, in which case troops should hold their position in a contaminated area.

c. Avoiding contaminated areas.—The effect of nonpersistent gases is of short duration, as the gases dissipate within 5 to 30 minutes, depending upon the terrain and weather conditions. The enemy's use of highly persistent agents, such as mustard, which usually contaminates for several days, offers the most danger to personnel crossing the contaminated area, due to the liquid splashes on the ground, grass, and underbrush. If possible, these areas should be avoided through proper reconnaissance.

■ 53. PROTECTION AGAINST CHEMICAL ATTACK FROM THE AIR.—

a. General.—(1) No area can be designated as a safety zone against chemical attack from the air. Both light bombardment and bombardment aviation are equipped for chemical attack on targets within their respective flying range. Bombardment aviation is equipped for projection of chemical bombs; light bombardment aviation is equipped with tanks for spraying chemical agents in the form of a fine rain or mist.

(2) Using proper methods of concealment, the extent of an area which can be gassed in this manner depends upon the number of planes engaged.

(3) In the forward areas, it is necessary that all chemical protective equipment be ready for instant use at any hour of the day or night. All installations within bombing range should be supplied with chemical protective equipment necessary for the protection of personnel and supplies against chemical agents released from air bombs or spray tanks.

b. Movements by rail.—Entraining and detraining points are the best targets for gas attacks. It is therefore desirable

to utilize a number of such points distributed along the railway line in order that a large troop concentration in any one area may be avoided. Concealment and secrecy of such operations must be sought. Once entrained in covered cars, troops provided with gas masks will be fairly safe against gas attacks.

c. Motor convoys.—Measures aimed at avoiding gas attacks by aircraft upon motor convoys are the same as those applicable to other forms of air attack. Until an air attack is actually launched, it is impossible for the ground forces to determine whether high explosive bombs or chemical agents, or a combination of both, are to be employed. Against high explosive, it is advisable that troops leave their trucks and deploy; however, such action will usually increase their vulnerability to chemical spray attack. The judgment of the commanding officer will govern the action to meet each situation as it arises.

d. Marching columns.—(1) In the case of marching columns of troops, whether dismounted or mounted, the possibility of gas being used by attacking aircraft imposes the same complication in the problems of protective procedure as in the case of motor convoys; that is, the impossibility of foretelling the kind of attack, whether with HE or chemical agents, or both, and the fact that protective formations against bombing attack may be of little or no value against chemicals.

(2) In order to meet this dual situation, troops marching in column must have their chemical protective equipment ready for immediate use at all times. Flank guards, posted and moving with the column at strategic points along the route of march, insure comparatively quick alarm of approaching planes. Troops can adjust their chemical protective equipment as they deploy, assuming any new formation in time to meet an air attack either by HE or chemical agents.

e. General security provisions.—Attack by enemy airplanes equipped for chemical operations can be made upon a marching column at any point along its route but such attacks are more likely to be made at places where nearby woods or hills afford some concealment for the planes in

their approach. Defiles and valleys where wind velocity is likely to be retarded are more likely to be selected for attack than are open, wind-swept areas. Security provisions in general against air attack on moving columns may be briefly outlined as follows:

(1) *Warning of attack.*—Distant warning from mobile radio observation unit and immediate warning from observation patrols sent out from the column.

(2) *Concealment.*—Night movements are the general rule; varied use of road nets to deceive the enemy as to exact route, since air attacks are normally planned in advance with the view to striking a moving force at some certain point on its probable route.

(3) *Protective formation.*—Increased intervals between units upon approaching defiles where observation of approach of aircraft would be very restricted.

(4) *Movement.*—As soon as possible after chemical attack by airplanes upon a column, troops are moved upwind out of the gassed area, since, aside from contamination of ground and vegetation, the vapor concentration in such an attack is likely to be very high. The upwind edge of the gassed area will probably be nearby in most cases. Immediate inspection is made to determine the results of the attack and such first-aid and decontamination measures as practicable are taken forthwith.

f. Use of woods for protection.—While as a general rule of protection against gas, wooded areas will be avoided, there are nevertheless some possible exceptions. For marching columns, it will sometimes be the case that secrecy of movement can be secured by movement through woods thus avoiding air attack of any kind. Where there is a line of woods in full leaf parallel to a road and an air attack is expected, it is advantageous for the column to move off the road along the edge of the woods. If then attacked by airplanes using chemicals, troops seek cover in the woods, emerging therefrom as soon as the airplanes have passed. The thick foliage overhead in such a case will probably afford considerable protection against liquid chemical spray. If necessary to pass through high grass or underbrush to reach the woods, it is preferable to remain in the open.

■ 54. PROTECTION DURING MOVEMENTS INTO COMBAT.—*a. Camps and bivouacs.*—High ground is sought for gas protection. Heavily wooded patches, especially ravines, are avoided. Water sources at camp sites are carefully examined for gas contamination before use. Gas sentries are posted over sleeping men. Where troops are halted for the night in positions likely to be attacked with persistent agents, alternate positions for each unit to occupy in case of necessity are selected.

b. Selection of routes of approach.—(1) Routes of approach along high ground are preferred. Wooded defiles and ravines are regarded with suspicion, avoided if possible and, in any case, reconnoitered for gas before marching into them.

(2) In addition to the route selected for a movement, one or more alternate routes for use in case the route first selected is gassed should be reconnoitered in advance. Selection of alternate routes is particularly applicable in the case of units advancing to assembly positions. While the zone of advance may be clear of gas when it is reconnoitered, it may be gassed later on. The enemy will seek to lay down gas at a time calculated to obtain maximum effect and when it is too late for the advancing force to change plans.

(3) In situations where it is likely that persistent gas will be encountered, advance guards or other covering forces will invariably include a gas reconnaissance party and personnel equipped for decontaminating operations. Such troops, provided with protective clothing, necessary tools, and decontaminating chemicals, will be able to deal with minor gas situations encountered on the march, such as contaminated bridges, road junctions, and obstacles on the road, thus obviating serious delays of the main body. Decontamination troops of each combat battalion should be provided with a truck, carrying tools, protective clothing, decontaminating materials, and with a squad wearing protective clothing, ready to move forward promptly when such situations are encountered.

(4) Upon encountering an area contaminated with persistent gas, its location will be reported immediately to higher authority and marked with signs indicating the gas danger and giving the date on which the gas was discovered. This

enables other troops approaching the area at some later date to determine whether it is still likely to be dangerous.

c. Avoiding contaminated areas.—(1) Areas contaminated by a vesicant gas should be avoided by passing them upwind. As to the downwind distance at which an area contaminated with a vesicant gas may be passed with reasonable safety, several factors must be considered: the depth and width of the area, the gas concentration, temperature, wind velocity, and time required to pass the area in the particular situation are all factors in the danger involved from gas. Where exposure will be for 10 minutes or less it is possible that masked troops could pass very close to the area without casualties resulting, even though the concentrations were very high.

(2) If troops are held up by enemy fire on the downwind side of a mustardized area, numerous casualties might result even though the area itself was small and the gas concentration low. Assuming no delay, it is probable that in most cases it will be reasonably safe to pass such an area on the downwind side at a distance equal to its depth. If the odor of gas is detected, gas masks will be worn.

d. Passing through contaminated areas.—Where entirely impracticable to pass around an area gassed with vesicant agents and troops must proceed forward, consideration should be given to all possible means of minimizing the danger of casualties in passing through the area. Factors to be considered are the depth of the area; gas concentration; probable length of time troops will be exposed; presence of thick vegetation; whether the terrain is bare or grass covered, wet or muddy, or dry and dusty.

(1) Where there is a hard-paved road through the area, it is probable that troops may pass through on the road without great danger of casualties from gas, provided they wear masks and that they do not remain exposed any appreciable length of time.

(2) Where the road through the area is unpaved and muddy, care should be taken to avoid splashing. On leaving the area, the muddy feet of men and animals should be cleaned with water, brushes, grass, etc. Bands of bleaching powder (chloride of lime) placed at the exit from such areas will assist greatly in neutralizing any agent picked up on shoes.

(3) Where the road or area to be crossed is dry and dusty, an effort should be made to prevent a thick cloud of contaminated dust from being raised.

(4) Wooded patches, ravines, hollows, and defiles, and especially lateral stream beds across the zone of advance, may be prepared for passage by sending forward details to cut lanes so that the bulk of the force may pass through without brushing against vegetation. Reconnaissance may result in the location of openings through the area so that little cutting of bushes, grass, or weeds will be required. Details of cutting lanes will be provided with protective clothing.

(5) Long grass and brush contaminated with mustard gas or similar agents may sometimes be burned to render the area safe for passage. During such burning, troops will be kept upwind of the area.

e. Occupation of a position.—In occupying a new position or in the relief of units at the front, unit areas should be reconnoitered in advance of the arrival of troops. In case the area is to be prepared for defense, plans for chemical protection should be coordinated with field fortification plans.

■ 55. PROTECTION DURING COMBAT.—*a. General plan for protection.*—(1) Each division and component unit at the front has a plan of protection against chemical attack. The guiding principle is to expose as few men as possible without weakening the plan of operations.

(2) In an offensive, the plan is limited largely to a predetermined scheme for shifting the position of units to avoid gassed areas and for dealing with such areas encountered in the zone of advance.

(3) In defensive situations, the plan should be carefully coordinated in the general scheme of defense. Among important considerations are timely withdrawal of troops from areas which are gassed with a highly persistent agent, provisions for covering such areas with fire or for their reoccupation as may be required, general check upon the protective installations and gas discipline, and special attention to the medical arrangements for prevention, handling, and removal of casualties.

(4) If possible, in defensive situations, a coordinated and predetermined plan for removal of units to alternate positions

should be provided in each division or independent smaller force. The alternate position to which any subordinate unit is to move must be such that there is no serious gap in the line and in general it should be such that the unit can continue to exert its fire power.

(5) Normally the occupation of an alternate position is carried out only on orders from the next higher headquarters. In no case should withdrawal from an original position be undertaken until it is clear that the enemy is using a highly persistent gas in sufficient quantity to render the area untenable.

(6) The battalion plan is made up to cover shifts of positions of companies or platoons within the battalion area in case the position of such companies or platoons becomes untenable due to persistent gas. This plan is submitted to the regimental commander, together with recommendation as to movement of the battalion in case of an attack rendering the whole battalion area untenable. The regiment, brigade, and division each in like manner prepare and submit their respective plans to the next higher headquarters.

b. Conduct of troops in chemical attacks.—Where nonpersistent gas is used, troops must prepare to repel an assault. Other than this, all unnecessary movement should cease until the gas has dispersed. Nonpersistent gas is generally employed in situations where the enemy has time and facilities to bring forward the necessary munitions. Since surprise is of great importance, such attacks are likely to be made at night or early in the morning when troops are asleep. After any gas attack, troops should be prepared for a second attack.

c. Importance of offensive action.—Artillery can be used to advantage to forestall gas attacks or prevent the enemy from exploiting them. Whenever installations or preparations for the projection of gas are located, they are promptly bombarded with a view to their destruction.

d. Occupation of vesicant contaminated areas.—(1) The length of time that men wearing ordinary clothing can remain in an area contaminated with a vesicant before becoming casualties will probably not be more than a few hours. Knowing this to be the case, such troops are unlikely to be of much value.

(2) When it is deemed imperative to utilize the position, as few men as are absolutely essential should be left in the area. They should be provided with all possible means of protection and they should be relieved after 2 hours, or sooner if practicable. It will sometimes be feasible to withdraw initially all men from the area, sending a small number back into it only when fire from this position is required.

e. Protection during pursuit.—In pursuit of a retreating force it is essential that there is no relaxation in gas-protective vigilance. The enemy is likely to make extensive use of gas, particularly the vesicant type, in rear-guard action. Pursuing forces then must be on constant guard against blundering into contaminated areas. Localities likely to be gassed to hamper pursuit should be carefully reconnoitered before troops enter them.

■ 56. MEASURES TAKEN AFTER A CHEMICAL ATTACK.—*a.* As soon after a gas attack as possible, first aid should be given to gas casualties and provision made for their evacuation. Gasproof shelters, if they have been provided, should be ventilated and prepared for another gas attack. Contaminated food and water should be disposed of; contaminated weapons and equipment should be decontaminated and all metal parts oiled; and contaminated areas that must be occupied should be decontaminated. From the attack, it may have been found that additional protective equipment is required or that some of the equipment on hand should be replaced. This equipment should be promptly requisitioned and supplied to the using units and individuals.

b. Report will be made to higher headquarters on the time, place, and extent of the chemical attack, the agent used, if known, and the type of weapon used to project it. As soon as possible, the extent of areas unfit for occupation because of the presence of a highly persistent agent will be determined and a report thereof made to higher headquarters.

c. Areas heavily contaminated with persistent gas will be marked and, when necessary, sentries posted around them.

■ 57. STAFF FUNCTIONS OF CHEMICAL SERVICE IN TACTICAL PROTECTION.—*a.* *Advisory duty of chemical officers to com-*

manders.—It is the duty of the army, corps, and division chemical officers to keep their respective commanders informed at all times of the nature of enemy chemical attacks and the agents being used. In an advisory capacity, they formulate plans for tactical protection in the form of standing orders or as a part of the chemical annex to field orders or special orders.

b. Methods used to test new chemical agents and protective measures.—Included in army troops is a chemical field laboratory which the army chemical officer employs in determining the nature of new enemy chemical agents and in testing and improvising such additional protective measures as may be found necessary. Close liaison is established between the corps and division chemical officers so that chemical intelligence may be transmitted to the army chemical officer with the least possible delay.

SECTION IX

TRAINING IN DEFENSE AGAINST CHEMICAL ATTACK

■ 58. GAS DISCIPLINE.—*a Definition.*—(1) For the individual soldier, good gas discipline means that he has a proper respect for the efficiency of gas, but no unreasonable fear of it; that, knowing the value of his protective equipment, he takes care of it; that, upon detection of gas or sounding the alarm, he promptly adjusts his mask and warns others. It implies such training in use of the mask that he is able to wear it for a considerable time and carry on his duties without undue fatigue and that he does not remove his mask until properly ordered to do so.

(2) Collectively, good gas discipline implies maintenance of morale under gas conditions; that there is no panic, but, on the contrary, orderly and prompt execution of the prescribed protective procedure.

b. Psychological reaction.—Psychology plays an important part in gas discipline. Most men are filled with fear before they come in contact with a chemical agent. Proper training in defense against chemical attack will eliminate this. It should be impressed upon men that the Army gas mask, properly used, gives 100 percent protection for the eyes and

lungs, and the protective clothing the same against the vapors of mustard gas. Men should be trained to look upon chemical agents as upon any other weapon of war, and should understand that when they make intelligent use of the protective equipment given them, they can encounter chemical attacks with few casualties.

■ 59. RECRUIT TRAINING.—*a.* Before the recruit is turned to duty he should be given training in the rudiments of individual protection. This training should consist of gas mask drill, care and handling of the gas mask, and the identification of chemical agents.

b. When the recruit has become reasonably proficient in the steps and marching, and begins instructions in the weapons with which his organization is armed, he should be issued and required to wear a gas mask. Fifteen or twenty minutes a day can be devoted to gas mask drill at odd periods to vary the instruction.

■ 60. PHASES OF TRAINING.—Training in defense against chemical attack is divided into three phases: *First phase*, the school phase; *second phase*, training of the units, with the assistance of the unit gas officers and noncommissioned officers, in the mechanics of defense against chemical attack; *third phase*, application of defense against chemical attack to combat by including gas situations in field problems for battalions, regiments, brigades, and divisions.

a. First phase.—(1) *In peacetime.*—This phase consists of schools during the indoor season to train unit gas officers and noncommissioned officers and to insure the availability of competent instructors for the troops. This is usually accomplished by conducting a course in defense against chemical attack at each post, camp, and station. The instructor is normally the corps area or division chemical officer. However, graduates of the Chemical Warfare School may perform this duty when the necessity for economy in mileage funds or for any other reason it appears desirable. In some instances, notably in foreign departments where stations are not far apart, it is desirable to order the students to a central point for this course, particularly when extra facilities, such as a chemical company with its allowance of munitions, is

available at a particular station. After this course, provision is made in the normal garrison school for the training of company noncommissioned officers and any company officers who may need instruction to enable them to train their units.

(2) *In event of mobilization.*—In order to acquire the uniformity required for operations, the unit gas officers and non-commissioned officers are normally assembled and trained under the personal supervision of the division chemical officer. These trained specialists then in turn will instruct and assist the troop officers in training their units.

b. Second phase.—This phase consists of the practical training of organizations in fitting the gas mask, gas mask drill, identification of agents, masking animals, accustoming men and animals to pass through gas and smoke, marching and drilling in masks, the construction and maintenance of gasproof shelters, and degassing of areas and equipment. In peacetime, the gas masks of the division, post, or camp will, in general, be pooled for this purpose.

c. Third phase.—This phase consists of introducing into normal tactical field exercises of the battalions and higher units, chemical warfare features which will require the unit gas officers and gas noncommissioned officers to function in their respective positions; unit commanders will make decisions relative to defensive features; and all ranks will operate while wearing the gas mask in tear gas and smoke. Care must be taken to avoid emphasizing unduly the chemical warfare features of the exercise to the extent of making the exercises illogical or tactically unsound. Insofar as practicable, situations involving defense against chemical attack will be made a part of tactical exercises which are normal to the field training of units instead of formulating special problems for the particular purpose of illustrating defense against chemical attack.

■ 61. IDENTIFICATION OF CHEMICAL AGENTS.—An important phase of training in individual protection is the development of the ability of individuals to recognize the presence of chemical agents by their odor. To aid in this instruction, there is available for indoor instruction an identification set which is called "Set, Gas Identification, Instructional," and

for outdoor instruction an identification set which is called "Set, Gas Identification, Detonation."

■ 62. SET, GAS IDENTIFICATION, INSTRUCTIONAL.—*a. Description.*—This set consists of seven 4-ounce wide-mouth glass bottles, including two bottles containing charcoal saturated with mustard (HS); one each containing charcoal saturated with chlorpicrin (PS) and lewisite (MI); one each containing diphenylamine chlorarsine (DM) and chloracetophenone (CN) as a solid; and one containing simulated phosgene (CG) (triphosgene), a solid, which upon contact with the air decomposes, giving off pure phosgene. Gas will not generate in a closed bottle of the simulated CG. The charcoal used in these bottles is standard gas mask type activated charcoal which has been thoroughly dried. Enough chemical agent is added to saturate the dry charcoal.

b. Replacements.—When several sniff bottles have deteriorated to the extent that vapors are no longer given off, requisition should be made for the necessary sample replacement sets. These replacement sets consists of units of two bottles of agents packed in a wooden box. Upon receipt of the sample replacements, the newly filled bottles should be removed and placed in the standard set. The empty bottles should be placed in the sample replacement box for immediate return shipment.

c. Precautions.—Personnel opening new bottles and containers, or those which have been closed for some time, should wear perfectly adjusted gas masks. Occasionally, pressure builds up within bottles that have not been opened for long periods which is sufficient to throw charcoal or dust into the opener's eyes. It is therefore advisable to have all bottles opened by masked personnel sometime before instruction is begun and then recorked, after which no great accumulation of pressure can be expected for another 24 hours. *Bottles not in use should be kept carefully corked at all times.* Care must be taken to insure that bottles and tubes are stored where they cannot be tampered with.

d. Method of testing.—(1) The proper method of smelling the chemical agents in the bottles is to take a moderately full breath immediately before opening a sample bottle. On opening, caution should be used to keep the face away from

the bottle. The bottle should be placed in the left hand and held about 10 inches in front of the nose and the right hand used to fan the air across the mouth of the bottle toward the nose. At the same time, air should be sniffed in and out of the nose, avoiding deep inhalations. If the odor is not discovered the first time, the bottle should be brought progressively closer until a distinct odor is obtained. As soon as the odor has been detected, replace the stopper in the bottle.

(2) If the odor does not correspond to any described in paragraph 6, the student should note exactly what the agent smells like to him. There is more variation in odor perception than in any other faculty; hence, it is to be expected that different men will describe the same odor in different terms. All odors become more penetrating and stronger as the concentration is increased, so that the concentration as well as the individual variation in odor perception must be considered when identifying chemical agents from sniff bottles.

(3) There is no danger in connection with smelling chemical agents prepared in this way. Best results are obtained if only one or two agents are sniffed per day. The method of instruction used in sniff bottles is applicable to small groups only and is exceptionally applicable in the training of instructors, hence, will usually be limited to use in training gas officers and gas noncommissioned officers.

■ 63. SET, GAS IDENTIFICATION, DETONATION.—*a. Description.*—This identification set consists of 48 sealed pyrex glass tubes, each 1 inch in diameter, 7½ inches long, and containing approximately 1 ounce of the agent or a solution thereof. Twelve tubes each of mustard gas (HS), lewisite (M1), phosgene (CG), and chlorpicrin (PS), are provided.

b. Method of shipment.—Multiple tube containers and individual tube containers cannot be shipped by common carrier unless securely packed in the steel shipping container; consequently, it is necessary to return the complete set in the shipping container when replacements are required.

c. Method of use.—This set is intended for use outdoors and will be found valuable in training individuals to identify chemical agents under field conditions. The individual gas

tubes containing the agent should be prepared for detonation by attaching to them one or two No. 8 commercial detonators as shown in figure 45. The gas tubes should be wired for detonation as shown in figure 46. Printed instructions for the use of this set, as well as the diagrams in figures 45 and 46, are placed in an individual tube container and packed in each multiple tube container. The following prac-

GLASS TUBE FOR USE IN FIELD IDENTIFICATION
OF
CHEMICAL AGENTS

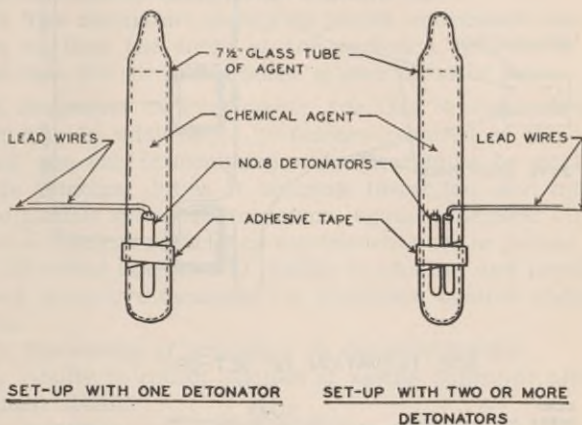

FIGURE 45.—Glass tube for use in field identification of chemical agents.

tical details should be observed when using this identification set:

(1) A line of holes about 10 yards apart should be dug at right angles with the wind direction and one tube of agent placed in each hole. One tube is sufficient for about 25 men. At a signal, an assistant detonates the agents by means of an exploder and the instructor causes the students to sniff the air when the cloud reaches them. In a shifting wind the students will change position accordingly so as to be in the path of the agent. As soon as the students have

obtained the odor of the agent, they move out of the cloud at right angles to the wind direction.

(2) The exploder box should be placed about 25 yards upwind from the firing line. The class, or observers, should be placed from 30 to 35 yards downwind.

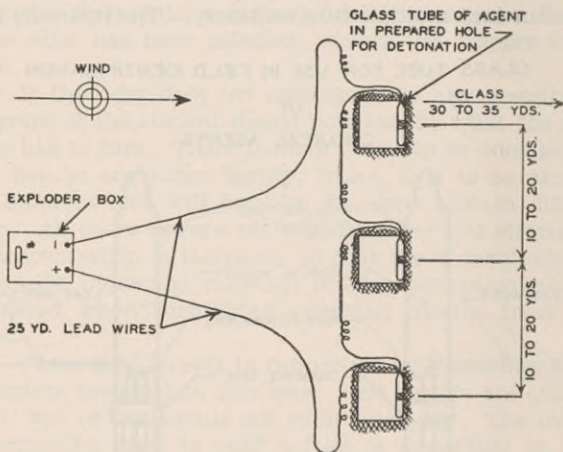

SIDE ELEVATION OF SET-UP

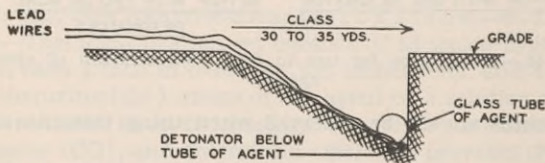

FIGURE 46.—Diagram of detonation of agent set up for field identification.

(3) When persistent agents are used, have a spade or piece of board handy and take a sample of the earth from the detonation hole, then have each observer pass by and sniff the odor of the agent given off by the earth.

(4) Pieces of glass and liquid spray may be thrown as far as 15 yards. Be sure no person or animal is within this danger radius when the gas tubes are detonated.

(5) Vegetation in the immediate vicinity of the detonation hole may be contaminated from HS and M1 firing, and the ground in the detonation hole is always dangerous for some time. Suitable precautions must be taken to prevent burns.

(6) After a demonstration, always fill up detonation holes and remove pieces of glass and wire from the detonators.

(7) Use one No. 8 detonator only on phosgene (CG), chlorpicrin (PS) and lewisite (M1) gas tubes; two No. 8 detonators are usually desirable on mustard (HS).

(8) The detonators should be placed underneath the gas tubes so that the force of the explosion will throw the liquid into the air and produce a good cloud of vapor.

■ 64. STANDARDS OF PROFICIENCY FOR GAS NONCOMMISSIONED OFFICERS.—In addition to proficiency required of the individual, the gas noncommissioned officer must be qualified in the principal duties of training, inspection, and intelligence as unit specialists in defense against chemical attack. These additional proficiency requirements are as follows:

a. Chemical agents.—(1) Ability to identify and prescribe correct protective measures for protection against chemical agents.

(2) Knowledge of procedure in decontamination.

(3) Ability to collect samples of agents during or after a chemical attack.

(4) Rendering of prompt intelligence reports.

b. First-aid treatment for gas casualties.—(1) Knowledge of first-aid treatment required for prevention of and aid to gas casualties.

(2) Ability to instruct in first-aid measures for gas casualties.

c. Gas masks.—(1) Knowledge of the methods of disinfection and fitting of gas masks.

(2) Ability to make prompt repairs to the gas mask (field repairs only).

(3) Conduct and inspection of gas mask drill.

d. Protective clothing.—(1) Knowledge of use of protective clothing during decontamination of mustardized areas and equipment.

(2) Ability to fit and inspect personnel equipped with protective clothing.

e. Gasproof shelters.—(1) Location.

(2) Knowledge of methods of ventilation and maintenance.

(3) Ability to inspect effectiveness.

f. Duties of gas sentries.—(1) Knowledge of the duties of gas sentries and their instruction.

(2) Ability to inspect and maintain gas alarm devices.

g. Protection of animals.—For those having duties in connection therewith—

(1) Knowledge of protection required for animals.

(2) Ability to instruct personnel in animal protection.

h. Training.—(1) Knowledge of the methods of training in defense against chemical attack.

(2) Ability to train and instruct individuals in defense against chemical attack.

■ 65. TRAINING OF UNIT GAS OFFICERS AND NONCOMMISSIONED OFFICERS.—Unit gas officers should be trained in individual schools conducted by the division chemical officers. A minimum of 30 hours should be devoted to this course. A guide for the preparation of an instruction course for unit gas officers and noncommissioned officers follows:

Subject	Practical exercises	Conference hours	Total hours
AGENTS.....			7
Characteristics and identification of chemical agents.....	3	3	
Effect on men and animals. First-aid treatment.....		1	
PROTECTION.....			10
Individual:			
The gas mask (including horse mask for mounted units).....	½	½	
Protective clothing.....		½	
Gas chamber.....	1		
Collective:			
Alarm devices.....	½		
Protective covers.....	½		
Gasproof shelters and collective protectors.....	1		

Subject	Practical exercises	Conference hours	Total hours
Decontamination:			
Decontaminating materials.....	½		
Methods of decontamination.....	1		
Matériel:			
Care.....		½	
Repair and maintenance.....	1		
Supply.....		½	
Drill:			
Gas mask.....	2		
WEAPONS.....			2
Weapons and ammunition using chemical agents, including grenades, smoke pots, and irritant candles.....	1	1	
TACTICS.....			7
Use of lethal and nonlethal gases.....		1	
Use of smoke.....	1	1	
Chemical intelligence and effect of weather.....		1	
Procedure, before, during, and after a gas attack.....		1	
Field exercise.....		2	
DUTIES.....			1
Unit gas officer and noncommissioned officers.....		½	
Army, corps, and division chemical officers.....		½	
PROBLEMS ON PROCEDURE AND REPORTS.....	2		2
EXAMINATION.....		1	1
TOTAL HOURS.....	15	15	30

■ 66. TRAINING OF TROOPS.—*a.* The following course of instruction (15 hours) in the essentials of defense against chemical attack is furnished as a guide for training of troops, including recruits:

First lesson

Conference—Purpose of course. 10 minutes.

Procedure: Talk briefly explaining (1) course of instruction, (2) general problems of protection, and (3) general methods and measures for obtaining adequate protection. Conclude with questions on the most important points discussed.

Conference—Chemical agents. 20 minutes.

Procedure: Discuss (1) general properties of chemical agents, their physiological effect and identification, (2) general effect of weather and terrain, and (3) difference between lethal and irritant agents. Conclude with questions on important points discussed.

Practical exercise—Chemical agents. 20 minutes.

Procedure: Pass a sample agent around the group. Have various members describe the odor. Compare with the description given in paragraph 6.

Equipment required: Set, gas identification, instructional.

Second lesson

Conference—Chemical agents. 30 minutes.

Procedure: Discuss (1) characteristics of lung irritants and sternutators, (2) their physiological effect, (3) persistency, and (4) general tactical use. Explain method of identification in the field. Conclude with questions on important points discussed.

Practical exercise—Chemical agents. 20 minutes.

Procedure: Pass samples of above-discussed agents around the group requiring various members to describe the odor and identify the agent.

Equipment required: Set, gas identification, instructional.

Third lesson

Conference—Protection. 20 minutes.

Procedure: Discuss (1) individual protection, (2) types of gas masks and their sizes, and (3) protective clothing. Describe the various parts and functions of the service mask. Conclude with questions on important points discussed.

Equipment required: A service gas mask.

Practical exercise—Protection. 20 minutes.

Procedure: Issue service gas mask. Have members sling and adjust mask. Fit mask and record sizes. Have members remove and replace mask. Inform members to bring their

masks to all lessons. The instructor should bring a diaphragm gas mask.

Practical exercise—Drill. 10 minutes.

Procedure: Demonstrate gas mask drill by the numbers and at the command GAS.

Fourth lesson

Conference—Chemical agents. 20 minutes.

Procedure: Discuss (1) characteristics of lacrimators, (2) their physiological effect, (3) persistency, and (4) general tactical use, particularly in training and riot duty. Explain method of field identification. Conclude with questions on important points discussed.

Practical exercise—Chemical agents. 10 minutes.

Procedure: Pass samples of above discussed agents around the group requiring various members to describe the odor and identify the agent.

Equipment required: Set, gas identification, instructional.

Practical exercise—Drill. 20 minutes.

Procedure: Conduct gas mask drill by the numbers, (1) sling carrier, (2) adjust mask, (3) check mask, (4) test for gas, (5) remove mask, and (6) unsling carrier. Correct all faults.

Fifth lesson

Conference—Chemical agents. 20 minutes.

Procedure: Discuss (1) characteristics of vesicants, (2) their physiological effect, (3) persistency, and (4) general tactical use. Explain method of field identification. Conclude with questions on important points discussed.

Practical exercise—Chemical agents. 10 minutes.

Procedure: Pass samples of above discussed agents around the group requiring various members to describe the odor and identify the agent.

Equipment required: Set, gas identification, instructional.

Practical exercise—Drill. 20 minutes.

Procedure: Conduct gas mask drill by the numbers as in the fourth lesson and add, (1) inspect mask, (2) inspect carrier. Correct faults.

Sixth lesson

Conference—Chemical agents. 20 minutes.

Procedure: Discuss (1) characteristics of incendiaries, (2) their physiological effect, (3) persistency, and (4) general tactical use. Review persistence and characteristics of all chemical agents. Conclude with questions.

Practical exercise—Chemical agents. 15 minutes.

Procedure: Cover from view the name on each sample of agent and pass them out to individuals or squad leaders if the group is large. Have the samples of agents identified preferably by written answers. Exchange samples.

If the group is large and the instruction can be done in the field, detonate various tubes of agents and have each agent identified with written answers.

Equipment required: Set, gas identification, instructional; set, gas identification, detonation.

Practical exercise—Drill. 15 minutes.

Procedure: Conduct gas mask drill without the numbers. Conduct formal inspection of gas masks when field equipment is not displayed.

Seventh lesson

Conference—Chemical agents. 35 minutes.

Procedure: Discuss and explain effect of various chemical agents on men and animals, giving first-aid treatment to apply in prevention of casualties. Conclude with questions.

Practical exercise—Drill. 15 minutes.

Procedure: Conduct gas mask drill without the numbers. By engaging in an athletic game, exercise, or other drill, divert attention temporarily from gas mask drill. As a surprise, give the command GAS. Repeat several times.

*Eighth lesson**Conference—Protection.*

20 minutes.

Procedure: Discuss (1) collective protection for men, animals, food, equipment, and munitions; (2) use of alarm devices and protective covers; and (3) purpose and proper use of gas-proof shelters. Conclude with questions.

Practical exercise—Drill.

10 minutes.

Procedure: Review all movements in gas mask drill without the numbers. Explain use of antidim. Explain the difference between, and purpose of, service and diaphragm gas mask.

Conference—Protection.

20 minutes.

Procedure: Discuss duties of gas sentries and special gas sentries. Explain necessity for strict compliance with "Standing orders for defense against chemical attack."

*Ninth lesson**Conference—Protection.*

35 minutes.

Procedure: Discuss procedure (1) in preparing to meet a chemical attack, (2) during a chemical attack, and (3) following a chemical attack. Discuss protective air measures in general. Explain the dangers in passing through contaminated area; how to avoid such areas and how to pass through such areas when required. Conclude with questions.

Practical exercise—Drill.

15 minutes.

Procedure: Final review of all movements in gas mask drill. Conclude with questions on purpose of movements in drill and inspection. Demonstrate the horse mask to mounted men. Equipment required: Horse mask for mounted units.

*Tenth lesson**Practical exercise—Protection.*

50 minutes.

Procedure: Prepare a gas chamber. Explain the purpose of the gas chamber. Inspect fit of all masks. Release prescribed gas in gas chamber. Have men enter gas chamber, following procedure outlined in paragraphs 31 and 32.

Equipment required: Gas chamber or improvised tent and CN capsules.

Eleventh lesson

Conference—Protection. 20 minutes.

Procedure: Discuss (1) care of protective equipment in general, (2) method in storage, (3) care in training, and (4) disinfection of the gas mask. Conclude with questions.

Practical exercise—Protection. 30 minutes.

Procedure: Demonstrate (1) method of making repairs to protective equipment (gas mask TM 3-205 (now printed as TR 1120-35)) (2) use of company gas mask repair kit (for facepieces only), and (3) use of regimental gas mask repair kit for general repairs to service gas masks. Conclude with questions.

Equipment required: Kit, repair, gas mask, company; kit, repair, gas mask, regimental.

Twelfth lesson

Practical exercise—Tactics. 1 hour.

Procedure: During the conduct of regular drill (squad, platoon, or firing battery), represent a gas attack by subjecting the unit to a nonlethal chemical agent so that men may become accustomed to wearing the gas mask without cessation of their normal activities. Tear gas is suitable for this instruction. The attack should come as a surprise and be repeated at least once, testing for gas following each attack.

Equipment required: Tear-gas candles or grenades; gas masks for all troops.

Thirteenth lesson

Practical exercise—Tactics. 1 hour.

Procedure: During the conduct of regular maneuvers or exercises (platoon, company, battery, or troop), include the use of smoke set up by smoke candles or other prescribed munitions to screen advance or withdrawal of troops. Situations so selected should be tactically sound.

Equipment required: Smoke pots or candles; gas masks for all troops.

*Fourteenth and fifteenth lessons**Practical exercise—Tactics.*

1 hour.

Procedure: During the conduct of regular maneuvers or exercises (company, battery, troop, or larger unit), include the use of a nonlethal chemical agent simulating the enemy's employment of a highly persistent lethal agent such as the vesicant mustard. Have the troops take the necessary protective measures to provide tactical security.

b. For troops well-seasoned and in a high stage of gas discipline, the above training may include, in addition, (1) laying of smoke screens and (2) defense against nonlethal gas attacks, if, in the particular situation selected, it is tactically sound to do so.

Equipment required: Simulated mustard, CN solution, or substitute materials such as crankcase drainings, lime water, etc.; chloride of lime or ordinary slaked lime for decontamination work; gas masks for all troops.

■ 67. TRAINING EQUIPMENT.—The following matériel is desirable in conducting courses of instruction:

a. Chemical warfare matériel.

Gas mask for each individual.

CN capsules (for charging gas chamber).

Set, gas identification, instructional.

Set, gas identification, detonation.

Horse mask.

Smoke pots.

Tear gas pots or candles.¹

Kit, gas mask repair, company.

Kit, gas mask repair, regimental.

*b. Ordnance matériel.*Smoke and tear gas hand and rifle grenades.¹Smoke and gas shell artillery.¹

■ 68. RULES TO BE REMEMBERED.—The following rules connected with defense against chemical attack should be impressed upon the individual.

a. Do not carry anything in your gas mask carrier but the mask.

¹ Within prescribed allowances.

b. Do not neglect the gas mask or allow it to receive rough handling.

c. Do not throw away your gas mask. You may need it later on and it will save your life in a gas attack.

d. Do not give a false gas alarm.

e. Do not breathe after the gas alarm is given until you are sure that your mask is well adjusted to your face and that the facepiece has been cleared of gas by blowing vigorously into the facepiece while holding the outlet valve.

f. Do not remove your gas mask until permission to remove it is given by an officer or a gas noncommissioned officer.

g. Do not enter an unprotected dugout immediately after a chemical attack.

h. Do not talk or move about unnecessarily during a gas attack.

i. Do not become panicky; keep calm and remember your protective equipment is effective if properly used.

j. Do not fail to realize that the enemy uses many different kinds of gases, sometimes alone, at other times mixed with other chemical agents, smoke, or high explosive.

k. Do not forget that clothing contaminated with mustard gas should be removed as soon as possible.

l. Do not remove another man's clothing or handle equipment that is contaminated with liquid mustard gas unless you are equipped with protective gloves.

m. Do not forget that mustard gas remains in an area for days.

n. Do not enter an area contaminated with mustard gas unless equipped with protective clothing and gas mask.

o. Do not remain for any length of time in an area contaminated with mustard gas, even if equipped with protective clothing and gas mask, unless required by the tactical situation.

p. Do not fail to post a gas sentry over sleeping men.

q. Do not forget that when the wind is blowing from the enemy between 3 to 12 miles per hour, a cloud chemical attack from the enemy may be expected.

r. Do not forget that during a calm, in foggy or cloudy weather, and at night, ideal conditions exist for a chemical attack. Be on the alert.

s. Do not allow men to drink water or eat food contaminated with chemical agents.

t. Do not forget that all gas cases require, first, rest; second, warmth; third, fresh air.

u. Do not permit men who are casualties from inhaling gas to walk, talk, or move about.

v. Do not bandage the eyes of a gas casualty.

SECTION X

ANIMAL PROTECTION

■ 69. GENERAL.—Animals employed in the military service for transport, supply, and communication are riding and draft horses and mules and pigeons. Aside from any humanitarian impulses, these must be preserved and protected for the successful accomplishment of military operations.

■ 70. IMPORTANT BODY PARTS OF THE HORSE OR MULE.—For purposes of chemical defense and for protection of riding and draft animals, horses and mules are enough alike in anatomy and body structure to be considered as one animal. Chemical protection for the horse depends upon a knowledge of the important parts of his anatomy and body functioning. The chief parts of the horse as far as protection against chemicals is concerned, are the respiratory tract consisting of the lungs, trachea, pharynx, larynx, and nasal passages; skin; feet; eyes; and digestive tract consisting of the mouth, pharynx and esophagus, stomach and intestines.

a. *The respiratory system.*—An outstanding peculiarity is found in the horse's respiratory apparatus. The soft palate of the horse is a muscular curtain which separates the mouth cavity from the pharynx and respiratory passages except during swallowing, coughing, or neighing, thus preventing him from breathing through the mouth at his will. For protection of the lungs and upper respiratory tract, it is only necessary to see that uncontaminated air is supplied to the nostrils. The air flow system of the upper respiratory tract is illustrated in figure 47. In general, the air passages and the lungs are extremely sensitive to the action of chemical agents of the casualty producing type.

b. The skin.—The entire skin area of the horse is affected by chemicals of the vesicant type, but the most vulnerable parts are those where the skin is tender, the hair is very fine or not present, and where the sweat glands are most

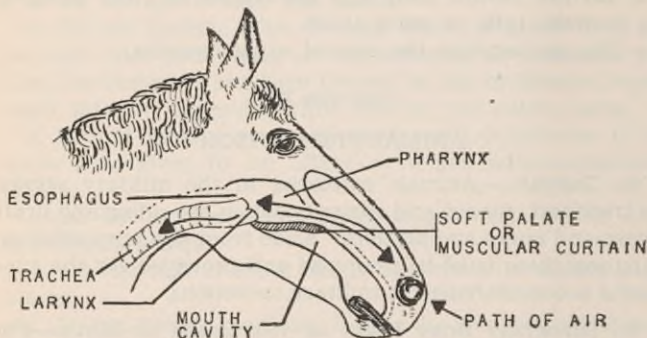

FIGURE 47.—Upper respiratory system showing air passage.

active. The most vulnerable parts are those shown in figure 48. The eyes of the horse do not appear to be affected by lacrimators, but are sensitive to vapors of vesicants. Liquid vesicants in the eyes will cause serious injury and may destroy the sight of the horse.

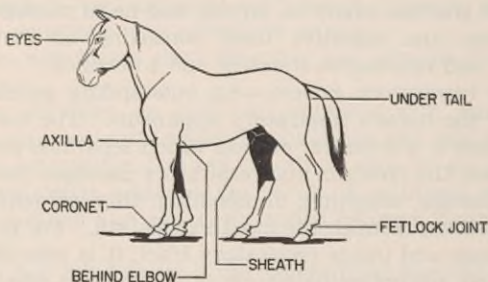

FIGURE 48.—Most vulnerable parts of the skin of a horse.

c. Feet.—Chemical wounds on the feet of the horse may incapacitate him. Injuries to the fetlock, coronet, the white line, and in the space between the bar and the frog are serious and may permanently disable the animal. (See fig. 49.)

d. Digestive tract.—Should the horse eat contaminated forage, graze on contaminated pastures, or drink water from ponds where chemical shells have exploded, he may develop extensive inflammation of the entire digestive tract with formation of ulcers in the mouth, stomach, and intestines, and possible later systemic effects.

■ 71. EFFECT, FIRST AID, AND PROTECTION.—The following table is arranged so as to show the effect of first-aid measures for, and protection against, the lung irritant and vesicant

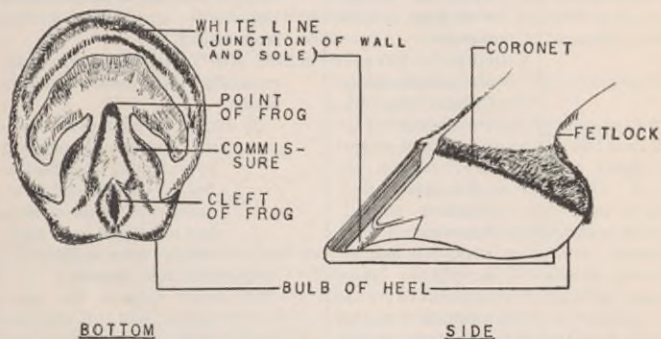

FIGURE 49.—Parts of foot vulnerable to vesicants.

classes of the chemical agents as applied to horses. The lacrimators and irritant smokes have been omitted since neither of these appear to affect the horse. The symptoms and protection of the incendiary type of agents, such as white phosphorus, are omitted in the following table. First aid for a white phosphorus burn consists of covering the wound with water or mud to prevent access of air until wound can be properly dressed.

THE HORSE IN CHEMICAL WARFARE

Physiological class	Lung irritants (choking)	Vesicants (blistering)
Examples (CW symbols).	Cl—CG—PS	HS—M1—ED
Symptoms and effects.	<p><i>a. Immediate.</i>—Warning to attendant by typical odor. Coughing of horse when in contact with high concentrations.</p> <p><i>b. Delayed.</i>—Several hours after exposure to light concentrations animal has appearance of depression, nostrils dilated, eyes staring, breathing labored. Recovers in about 5 days. In animals exposed to heavy concentrations, breathing is hurried and noisy, nostrils dilated with foaming to thick bloody discharge. The animal may die in about 48 hours.</p>	<p><i>a. Immediate.</i>—Warning to attendants by typical odor.</p> <p><i>b. Respiratory effects.</i>—Vapor causes inflammation and destruction of lining of nose and of membranes of respiratory tract. Pneumonia often follows.</p> <p><i>c. Skin.</i>—(1) Vapor affects fine skin, especially where profuse sweating occurs. (2) Liquid droplets cause swelling in 15 minutes followed by wrinkling and deadening of the affected skin. Later such places develop into ulcers and deep sores.</p> <p><i>d. Eyes.</i>—(1) Vapors cause swelling and a discharge from the eyes. (2) Liquid injures the eyes. Animal will rub eyes and show evidence of pain and itching within a few minutes. Blindness may result.</p> <p><i>e. Feet.</i>—Liquid or liquid contaminated earth in contact with the vulnerable parts of the foot may result in lameness and permanent injury to the hoof.</p> <p><i>f. Digestive tract.</i>—Contaminated food, forage, or water may cause inflammation and ulcers in the digestive tract followed by loss of appetite, weakness, and bloody diarrhea. If injury is due to M1 or ED, the horse may suffer from systemic arsenical poisoning.</p>
Protection.....	<p><i>a. Individual.</i>—Adjust horse mask on detecting gas.</p> <p><i>b. Collective.</i>—For stables, cover windows and doors with</p>	<p><i>a. Individual.</i>—Adjust horse mask for protection of lungs. Hoodwink eyes to protect from vapor and sprays. Also cover body with a blanket in preparation for airplane spray.</p>

THE HORSE IN CHEMICAL WARFARE—Continued

Physiological class Examples (CW symbols).	Lung irritants (choking) CI—CG—PS	Vesicants (blistering) HS—M1—ED
Protection.....	<p>blankets and stop up other holes and cracks with wet hay, newspapers, or mud.</p> <p>For picket lines and in open, avoid areas likely to be gassed.</p>	<p><i>b. Collective.</i>—For stables, cover doors and windows with blankets and stop up other holes and cracks with wet hay, newspapers, or mud. Avoid locating open shelters and picket lines in gassed areas, or positions likely to be gassed as woods in valleys.</p> <p>Detour around contaminated areas if on the march.</p> <p>Do not permit animals to graze or roll near contaminated shell holes or pastures. Cover forage from airplane spray attacks. Do not water from shell holes or small streams in contaminated areas.</p>
First aid.....	<p>Adjust mask on horse or if mask is not available use a nose bag filled with wet hay to cover nose and mouth.</p> <p>Remove animal from gassed area, if possible by ambulance, otherwise with the least possible physical effort to the animal.</p> <p>Keep animal quiet and warm. Place affected animals in care of veterinary surgeon.</p>	<p><i>a.</i> Attendants must wear protective gloves and if available, protective clothing when handling cases of animals injured by vesicants.</p> <p><i>b.</i> For lung injuries, first aid is the same as for lung irritant cases.</p> <p><i>c.</i> For vapor contact on the skin of animals, wash with soap and water or water within 15 minutes. Continue washing for 30 minutes.</p> <p><i>d.</i> For liquid contact on the skin, cover spots or skin areas with bleach paste (two parts water, one part commercial chloride of lime), and remove within 5 minutes. Wash with running water for 30 minutes. If no bleach paste is available, use soap and water or water alone. For best results the treatment must begin early, within 10 to 15 minutes.</p> <p><i>e.</i> After crossing contaminated ground, the feet should be cleaned and thoroughly washed.</p> <p><i>f.</i> Horses with eye injuries should be tied short to keep from rubbing and further irritating the wound.</p>

THE HORSE IN CHEMICAL WARFARE—Continued

Physiological class	Lung irritants (choking)	Vesicants (blistering)
Examples (CW symbols).	Cl—CG—PS	HS—M1—ED
First aid.....		Continued irrigation of injured eyes with a very weak solution of boric acid or baking soda (one-teaspoonful per pint of water) is beneficial. g. Hospitalize horses with large areas of skin swelling or indications of lung effect.

■ 72. HORSE MASK.—Three types of horse masks may be encountered in the service. These three are essentially the same in principle and differ mainly in details. All consist of a bag of several layers of chemically treated cloth. The bag fits in the mouth and over the upper jaw above the nostrils. Air is inhaled through the bag and into the respiratory system. On exhalation, the air may either pass out through the cloth bag or through an outlet valve, depending upon the model of the horse mask used.

a. *MII mask*.—The MII horse mask is shown in figure 50. Besides the chemically treated bag, the mask consists of a head harness and a canvas carrier which is hung on the pommel of the saddle. A heavy canvas mouthpiece prevents the horse from quickly chewing through the mask. The head harness keeps the mask in place when adjusted.

b. *MIII mask*.—The MIII horse mask differs from the MII in the following respects: An outlet valve is placed in the upper part of the bag; a fitting roll and a means of insuring a better closure between the mask and the face and lips is provided; a metal mouthpiece plate is substituted instead of canvas as in the MII type; a better carrier is furnished; and the head harness improved. These details are shown in figure 51.

c. *MIIIA1 mask*.—This model is a modification of the MIII mask. The outlet valve is eliminated.

d. MIII or MIIIA1 carrier.—The improved carrier is hung in front of the chest by means of a strap over the neck just in front of the withers. A snap and ring on a short strap attached to the carrier is secured in the lower halter ring so as to hold the carrier in place.

■ 73. TRAINING.—The respiratory system of the horse is very susceptible to injury by gas and because the horse cannot be trained to hold his breath, practice in quick and rapid adjustment of the horse mask is very important. Also, since some animals in the beginning fight against adjust-



FIGURE 50.—Horse mask MII and carrier.

ment and are very nervous when wearing the mask, it is necessary to overcome their fears by frequent practice and wearing. Untrained horses exhibit great distress from increased breathing resistance at first but with sufficient practice the animals become accustomed to wearing the mask and the distress and fear is greatly lessened. Systematic training in the adjustment will be carried out by units as described below.

a. Adjustment.—Being in the slung or alert position, (fig. 53) at the command GAS, the step-by-step sequence given below will be followed.

(1) *First step.*—(a) Riders or drivers put on personal masks as prescribed in paragraph 28.

(b) If mounted, dismount.

(2) *Second step.*—(a) Remove horse mask from its carrier.

(b) Make sure the fitting roll is fully opened.

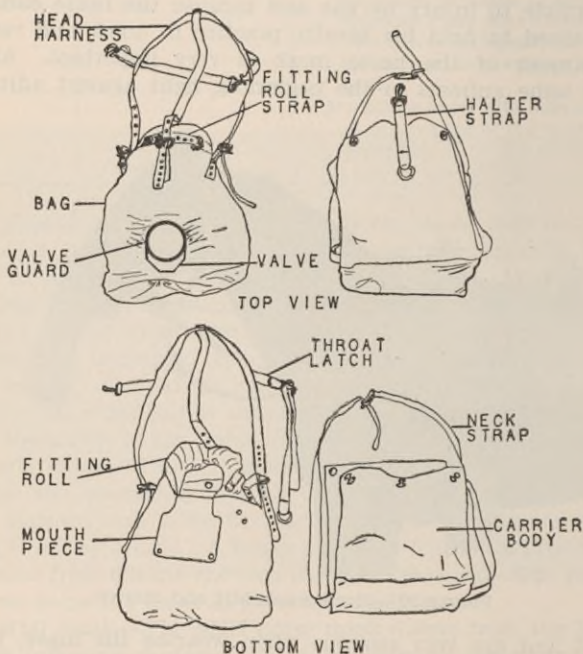

FIGURE 51.—Horse mask MIII and carrier.

(c) Place mouthpiece in the mouth with fitting roll well up on the face (fig. 53).

(d) Place head harness over the head and buckle throat latch.

(e) Tighten fitting roll strap until channels between the face and fitting roll are just closed, being careful that the roll is not too tight.



FIGURE 52.—Horse mask carrier in alert position.



FIGURE 53.—Placing mask in mouth of horse.

(f) Teamsters or horseholders continue with the remainder of team or group until all are masked. If any one horse is frightened or fractious, pass on to remaining horses, leaving the difficult ones until last.

(g) If originally mounted, mount. If not, stand to horse (fig. 54).

b. *Removal.*—With masks adjusted, and at the halt, the command is: **REMOVE AND REPLACE MASKS.**

(1) *First step.*—(a) If mounted, troopers or drivers dismount.



FIGURE 54.—Horse mask adjusted.

(b) Troopers or drivers test for gas.

(c) Troopers or drivers remove and replace personal masks.

(2) *Second step.*—(a) Loosen fitting roll strap of horse mask and secure buckle in readiness for adjustment next time.

(b) Unbuckle throat latch strap and slide off mask.

(c) Fold mask. With the MIII horse mask, see that outlet valve is not distorted in folding.

(d) Replace mask in carrier, close and buckle flap.

(e) Teamsters and horseholders continue with the remaining animals in charge. If originally mounted, mount.

c. *Wearing exercises.*—(1) Frequent adjustment and wearing exercises will be performed by units equipped with horse masks. These exercises are best conducted in connection with other mounted training and should not be scheduled as gas mask drills alone.

(2) Because gas attacks generally occur at night or early morning, it is especially important that stable guards and sentries over picket lines be required to practice adjusting the horse mask to the animals under their charge during darkness.

■ 74. CARE OF THE HORSE MASK.—The fabric of the horse mask is subject to deterioration unless it is aired and dried after use. If the fitting roll is closed too tightly when on the animal, the horse will become restive and try to chew through the fabric. A masked horse on a picket line or in a stable must be tied up short or he may step on the horse mask bag and remove or destroy the mask. Outlet valves must not be folded or creased in storage as a permanent set will occur in the rubber which will interfere with the proper functioning of the valve.

■ 75. INSPECTION.—Commanders of mounted organizations equipped with horse masks will inspect such equipment at frequent intervals for cleanliness, condition, and serviceability. This inspection will also include adjustment of masks on the animals.

a. *Procedure.*—(1) In preparation for the inspection, troop, battery, or company commanders will cause the organization to take a suitable formation. The commander then cautions, "Horse masks will be inspected."

(2) If mounted, troops will dismount and stand to horse. The organization commander then commands: **PREPARE FOR INSPECTION OF HORSE MASKS.** At this command, troopers or drivers remove the horse masks from the carriers and hold in front of the body until the approach of the organization commander. As the inspecting officer passes along the line, each soldier exhibits both sides of the

mask by turning it as directed by the inspector who visually examines both mask and slung carrier.

(3) Upon completion of visual horse mask inspection of the organization, the commander commands: GAS. Horse masks are adjusted and the inspector observes each horse for fit and adjustment of the mask.

b. Ceremonies.—Organization commanders may include inspection of horse masks at an appropriate time during mounted inspection ceremonies.

■ 76. PIGEONS.—*a. Effect of chemicals.*—(1) By inference from the known effects of the common casualty producing chemical agents on small animals, pigeons may be expected to be highly susceptible to respiratory irritation. However, the pigeon consumes a relatively small amount of air when caged or in a pigeon loft, and when in the air, nearly always flies high enough from the ground to escape the gas cloud.

(2) The possibilities of vesicant action on the outside skin are very small since the feathers should provide much natural protection.

b. Protection.—Since individual protection for pigeons is impractical, only group protection is practiced. This resolves into two types; first, protection of pigeon lofts and second, protection of pigeon cages or baskets. In either case, the principles are much the same.

(1) The loft is protected by sealing all holes to the compartments where the pigeons are kept except ventilation spaces which are stopped by means of chemically treated gas proof blankets.

(2) The pigeon basket is protected by means of a bag of chemically treated flannelette. Dimensions of the bag are 15 by 15 by 24 inches, and it is designed to fit over the pigeon cage. A drawstring closes the bag tightly when it is in use. The pigeon bag is shown in figure 55.

(3) When for any reason pigeons cannot be protected, they should be released at once.

SECTION XI

TRAINING MASK MI

■ 77. DESCRIPTION.—The training mask has been developed for the purpose of supplying the Army with a cheap and

lightweight gas mask for training purposes. It differs from the service mask in weight, in construction of the facepiece, shape and size of the canister, and in the shape, weight, and size of the carrier. The training mask is essentially a snout type mask and is without hose.

a. The *facepiece* of the training mask is a universal size rubber facepiece fully molded with integrally molded air supply tubes and deflectors. The eyepieces are shaped to give the maximum amount of vision and are crimped on. The head harness attachments and chapes are riveted to the



FIGURE 55.—Pigeon bag.

facepiece by countersunk rivets. The facepiece has been shaped so as to provide the least amount of dead air space within the mask. Two types of training masks are furnished, differing only in construction of the outlet valve; one type is known as the mask, training, MI, and is equipped with outlet valve MIV, which consists of a molded rubber valve seat and a circular rubber disk attached by means of a rubber stud. The second type is known as the mask, training, MIA1, and is assembled with outlet valve MV, which is a modification of the standard outlet valve for the service

mask. It has a metal valve guard. Figure 56 illustrates the differences in the two masks as well as the principal parts.

b. The *canister* for the training mask is cylindrical in shape, and contains a mechanical filter and chemical filter similar to the standard service canister. The air enters

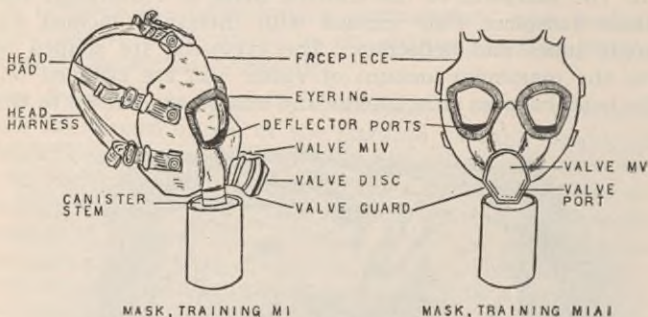
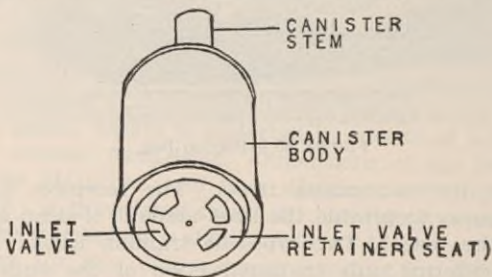

FIGURE 56.—Parts of mask.

through an outlet valve and passes through the canister stem which is attached directly to the facepiece, thence through air passages molded into the facepiece and impinges on the eyepieces. Nomenclature is shown in figure 57.



CANISTER, TRAINING MASK MI
FIGURE 57.—Parts of canister.

c. The *carrier* is a lightweight cloth bag furnished with a single adjustable shoulder strap and closed by means of a snap fastener. A body cord permits tying the carrier to the waist.

■ 78. **LIMITATIONS AND USE.**—The training mask is intended for training purposes only. However, the canister will protect against all standard chemical agents, but it should be noted that the amount of protection furnished against the standard casualty type agents is equal to many of the canisters used in the World War of 1917-18, and in the case of irritant smokes, superior. The life of the training canister is less than that of the latest standard canister. The resistance of the training canister is slightly greater than the standard canister, but less than the World War types. In case of emergency, it can be used for protection against a chemical attack. This gas mask must not be used around fires, within buildings where exhaust motor gas or carbon monoxide is to be found, in enclosed spaces where the oxygen content of the air may be too low to support life, or where concentrations of toxics are too high. The training mask will not be used for fumigation work.

■ 79. **GAS MASK DRILL.**—*a. General.*—The drills for the training mask follow the drills as set up for the standard service mask (par. 28) as closely as possible, considering the differences in construction. In general, the notes describing the movements and commands for the standard masks apply to the movements for the training mask. Where these differ, supplemental notes will be found in the following drill procedures. Similarly, general instructions in paragraph 28a apply.

b. Commands.—(1) *To sling the mask.*—With carrier held in left hand by shoulder strap (fig. 58), flap of carrier facing away from the body, the command is: 1. SLING, 2. MASK. With both hands grasp top of shoulder strap. Swing strap over the head, at the same time passing left elbow through loop (fig. 59). Place strap at junction of neck and right shoulder. Straighten out strap.

NOTES.—1. Mounted troops tie body cord loosely about waist on slinging carrier.

2. When either full field or light pack is worn, the training mask carrier is slung over equipment. When, for any reason, packs are removed in the field, the carrier is immediately reslung.

(2) *To unsling the mask.*—With carrier slung, the command is: 1. UNSLING, 2. MASK. With both hands grasp shoulder

strap and raise and slide it over the head. Hold shoulder strap in left hand, flap of carrier away from body (fig. 58).

(3) *To adjust the mask.*—Being at the slung position for detailed analytical instruction, the command is: 1. BY THE NUMBERS, 2. GAS. At the command GAS, stop breathing, dispose of arms and equipment. Remove head covering. Hold



FIGURE 58.—Preparing to sling carrier.



FIGURE 59.—Slinging carrier.

Note.—Mounted troops untie body cord before unslinging carrier.

bottom of carrier with left hand and with the right open flap (fig. 60). Grasp top of facepiece with right hand. Bring face piece smartly out of carrier (fig. 61) to a point in front of the face, chin high. Grasp facepiece with both hands, thumbs inside and below lower head harness strap, fingers extended outside facepiece, outer edges of palms together so

as to form a pocket for the chin of facepiece (fig. 62). Thrust chin forward (fig. 63).

TWO. Seat chin firmly in mask. Sweep head harness smoothly over the head without twisting straps. Center head pad well down on back of head (fig. 64).

THREE. Place left palm over outlet valve making sure it is closed (fig. 65) and exhale vigorously to clear inside of



FIGURE 60.—GAS. Open carrier.



FIGURE 61.—GAS. Withdraw mask.

mask of any gas. Resume breathing (in drill without the numbers). Beginning at the chin and with an upward and backward sweeping motion of the palms, press edges of facepiece smoothly on face (fig. 66). Also recheck seating of head harness.

FOUR. Replace headpiece. Fasten carrier flap. Resume original position.

(4) *To check fit of the mask.*—With mask adjusted, to check fit of mask the command is: 1. CHECK, 2. MASK. At the command MASK, exhale. Place palm of right hand over inlet valve making sure it is closed. Inhale deeply. The facepiece should collapse and cling to the face (fig. 67). Reseat mask by pressing edges and drop right hand. Resume breathing.

(5) *To test for gas.*—The mask being adjusted, the command is: TEST FOR GAS. Dismount, if mounted. Take a moderately full breath. Stoop down so as to bring the

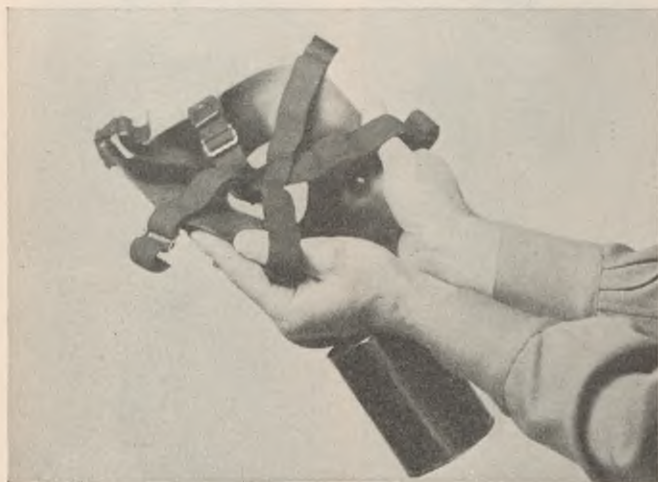

FIGURE 62.—GAS. Forming facepiece into pocket for chin.

face close to the ground but do not kneel, care being taken that the rifle or any part of the body except the feet does not touch the ground. Insert two fingers of right hand under facepiece at right cheek. Pull facepiece slightly away from right cheek and sniff gently (fig. 30). If gas is detected, readjust facepiece and resume the erect position. Close outlet valve by placing palm of left hand over outlet valve, making sure it is closed, and blow vigorously to clear inside of mask of any gas. Next, beginning at the chin, and with an upward and backward sweeping motion

of the palms of both hands press edges of facepiece smoothly on the face. Recheck fit and position of head harness.

Note.—Individuals should be trained to test for gas automatically and habitually before removing the mask.

(6) *To remove the mask.*—The command is: 1. REMOVE, 2. MASK. At the command MASK, prepare chin strap of headpiece for removal and grasp headpiece with left hand and



FIGURE 63.—GAS. Position ready to place facepiece on face.



FIGURE 64.—GAS. TWO. Straightening head harness.

remove it. At the same time, with the right hand grasp facepiece at junction of canister and facepiece and with an outward and downward motion pull facepiece clear of chin (fig. 68); pass facepiece up and over the head. Place canister with facepiece up under left armpit (fig. 69). Replace headpiece. Hold mask at junction of canister and facepiece

with the right hand and hold chest high at center of body (fig. 70).

(7) *To replace the mask.*—With the mask held in the right hand as at the end of REMOVE MASK, at the command, 1. REPLACE, 2. MASK, using the left hand, fold head harness inside of facepiece (fig. 71). Also, with the left hand, open



FIGURE 65.—GAS. THREE.
Closing outlet valve (side view).



FIGURE 66.—GAS. THREE
Smoothing facepiece.

and hold open flap of carrier. If carrier is difficult to open, hold carrier to the side with right hand which is holding the mask.

TWO. Place canister in top of carrier, outlet valve of mask to the front and using both hands, slide mask into carrier without forcing (fig. 72). With both hands close flap of carrier. Drop hands to side.

■ 80. VISUAL MASK INSPECTION BY INDIVIDUALS.—*a. General.*—The check of the mask as described in paragraph 79b(4) is not conclusive as to the complete serviceability of the gas mask. If, during execution of the command CHECK MASK, the facepiece fails to cling to the face and indications are observed



FIGURE 67.—CHECK MASK. Stopping inlet valve.

that a leak is in the mask other than between the facepiece edges and the face, a minute visual inspection and test must be made.

(1) If no leak is detected, the mask is assumed to fit and be in working condition.



FIGURE 68.—REMOVE MASK.
Removing facepiece.



FIGURE 69.—REMOVE MASK.
Replacing headpiece



FIGURE 70.—REMOVE MASK.
In readiness to place mask
in carrier.



FIGURE 71.—REPLACE MASK.
Folding head harness.

(2) If air leaks in between the face and facepiece, carefully adjust head harness by pulling up ends of each of opposing head harness straps nearest the leak, taking in the same amount of slack in each at the same time so as to keep head pad centered. Press edges of facepiece smoothly against the face and test again as in CHECK MASK. Tightening of the head harness should be done carefully and a little at a time until



FIGURE 72.—REPLACE MASK. TWO. Placing mask in carrier.

the leak is stopped. Headaches may result from head harnesses that are adjusted too tightly.

(3) If air leaks out after resumption of breathing, a sticking outlet valve is indicated. Remove mask and carefully open valve disk if a MIV valve, or open valve ports if a MV valve.

(4) If, after thoroughly checking seating of facepiece as described above, leakage of air other than around the edges

of facepiece is detected, the mask will be removed and a thorough examination made as described in *b* below.

(5) This inspection is not executed as a precision drill, but will be carried out in the manner explained in *b* below. For training and purpose of forming the habit for this inspection, the soldier will be taught this exercise in the sequence as shown.

b. Procedure.—(1) *For mask.*—Being in position of CHECK MASK and for training purposes only, the command is: 1. INSPECT, 2. MASK.



FIGURE 73.—ONE. Examining canister.

ONE. Remove mask and carefully examine canister (fig. 73).

NOTE.—The following faults may indicate a slightly defective canister: Missing inlet valve; edge of inlet valve disk stuck to the retainer; holes in disk of inlet valve, or permanent set of the rubber; insecure connections at the canister nozzle. Serious defects are holes in canister body; rust spots and weaknesses in canister body; loose or rattling contents. Rust and weaknesses in the canister body indicate that the chemical filling has been damaged by water getting inside the canister and that corrosion has set in. This will cause lowering of the chemical efficiency and marked increase in breathing resistance. Such a canister will be replaced.

TWO. Examine outlet valve (fig. 74). Minutely examine facepiece (fig. 75) and head harness (fig. 76). Men with un-serviceable masks report to instructor. Others place mask in carrier.

NOTES.—1. Sources of trouble are at the valve ports or edge of valve disk and connections at the outlet, valve stem, and with



FIGURE 74.—TWO. Examining outlet valve.

mashed or bent outlet valve guards. Valves with these defects will be replaced.

2. Occasionally after disinfection, and also during freezing weather, the valve ports or edges of the valve disk will freeze or stick, causing very high resistance to exhalation. When this happens, it is necessary to examine the valve and carefully open the ports or disks.

3. Sources of trouble are at the connections of the facepiece to the outlet valve and to the canister nozzle. Also, cracks and splits near eyepiece binder rings and near the rivets which secure the head harness chapes. The elastic webbing of the head harness

deteriorates very rapidly and must be inspected frequently. Holes and cracks in the facepiece may be patched. Head harness can be replaced.

(2) *For carrier.*—To inspect the carrier the command is: 1. INSPECT, 2. CARRIER. At this command, unsling the mask, open carrier, and hold by shoulder strap with the left hand. Examine outside of the carrier for condition, cleanliness, and completeness. Look inside the carrier to see that



FIGURE 75.—TWO. Examining facepiece.

the mask is correctly placed within. Button the flap and resling the mask.

■ 81. INSPECTION IN RANKS.—For inspection in ranks where training masks are issued, the procedure provided in paragraph 30 will be followed.

■ 82. STORAGE AND CARE.—In general, the same rules apply for care in use and storage of the training mask as for the

standard service gas mask described in paragraph 34*g* and *h*.

a. Deterioration.—The rubber of the facepiece and valve is subject to deterioration from heat, sunlight, and continued distortion. Water or excess moisture in the canister will destroy the chemicals and cause corrosion of the metal parts.



FIGURE 76.—TWO. Examining head harness.

b. Storage.—For storage within an organization and when not in use, the facepiece should be filled out by a crumpled newspaper form, the mask properly placed in the carrier without distortion, and hung by the shoulder strap from a hook in a cool dark closet.

c. Disinfection.—The mask is intended for personal use of the soldier and it is expected that he will have it in his possession or with his equipment. If for any reason the mask is to be exchanged, turned in, or used by another person, it must be disinfected in accordance with the instructions in paragraph 34*e*. During disinfection operation, care must be taken that the solution does not get into the deflector ports and thence into the canister. The mask is held by the canister with the facepiece down, swabbed with the disinfectant solution and all excess moisture shaken out before it is returned to an erect position.

■ 83. REPAIRS.—Repair procedure and description for the training mask will be published in TM 3-205 (now published as TR 1120-35).

■ 84. ADVICE TO COMPANY INSTRUCTORS.—*a. General training.*—A complete course for the soldier in defense against chemical attack for the company or similar unit will include conferences on recognition of and first-aid for chemical agents, duties of gas sentries, and other special subjects. These may be taken up during rainy-day periods and on such other occasions as convenient. Qualified unit gas officers and gas noncommissioned officers should be made available for this purpose.

b. Gas mask training.—In addition to general training, gas mask training under the direct supervision of the unit commander is mandatory. In gas mask training there are two objectives: first, instruction and repetitive drills for the purpose of forming correct habits of adjustment, testing, and care; and second, physical training while masked to develop the ability of the individual to perform his usual duties with the least loss of efficiency.

(1) The following schedule of instruction in gas mask training, but not including the general training in *a* above, is recommended for a company:

A Company Schedule for Instruction

SUBJECT	TIME (HOURS)
Nomenclature, description, and use of the gas mask (conference)-----	1/2
Instruction in drill:	Minutes
SLING AND UNSLING MASK-----	5
BY THE NUMBERS, GAS-----	20
BY THE NUMBERS, CHECK MASK-----	10
TEST FOR GAS-----	5
BY THE NUMBERS, REMOVE MASK-----	10
Lost time-----	10
Total-----	1
Review and repetition (three 1/2-hour periods)-----	1 1/2
Visual inspection procedure-----	1/2
Instruction in formal inspection in ranks-----	1/2
Practical examination and test (see note below)-----	1
Total (instruction only)-----	5

NOTE.—A practical gas mask examination procedure which may be carried out within an organization is as follows:

Erect a pyramidal or wall tent on the company drill ground and see that the tent is reasonably well closed around the bottom, near the corners, and at the top.

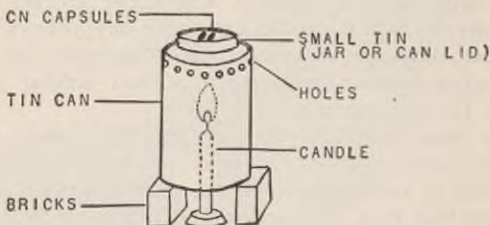

FIGURE 77.—Improvised tear gas generator.

Make a small generator out of a gallon tin can similar to the drawing in figure 77.

A concentration of tear gas is set up inside the tent by heating two issue capsules of CN tear gas over the improvised generator. If the concentration thins during the exercise, add another capsule.

The troops are passed through the field gas chamber twice in squad groups. The first time, masks are adjusted before entering the tent. The instructor inspects the adjustment before the student enters. Each squad remains in the tent 2 or 3 minutes and then files out. The instructor again inspects each individual to see if the mask fits and is gas tight. Leaks or faulty adjustments are indicated by laceration before the mask is removed. Masks are then aired until all squads have passed through the tent when the squads are again, in turn, sent into the tent.

At this second time, however, masks are not adjusted until the individual has entered. After two or three minutes in the con-

centration, the squad again files out. At this time, the instructor carefully inspects the adjustment of each mask while on the wearer before permitting removal. Faulty adjustment may be indicated by obvious channels and failure to seat the facepiece to the face, eyepieces not alined with the eyes and headpad not centered in the rear of the head. Failure of the individual to pass the test is indicative of inability to adjust his mask properly under conditions of stress. In such cases, more preliminary drill should be required.

After the test, tents should be thoroughly aired in the sun and wind before being put away.

For further description of this test see paragraph 32a(4)(b).

CAUTION: Do not let troops rub eyes after this test. As soon as possible, have them wash hands and face with soap and water to relieve the slight discomfort of the tear gas.

(2) Practice and physical training to be carried out in connection with other forms of training should include a daily exercise in wearing the gas mask, gradually increasing the time of wearing from a few minutes to a maximum of an hour or more. Gas mask wearing can readily be included in such nonprecision instruction and practice as physical training; massed games; extended order drills; service of the piece; transport driving; practice marches; field maneuvers; wiring and entrenchment training; small arms firing practice; and any other chosen by the unit commander. In addition to wearing exercises, periodical inspections by the unit commander should be required. Habitual daily check of the mask before each exercise should also be made.

APPENDIX

CHECK LIST FOR THE PREPARATION OF ORDERS FOR DEFENSE AGAINST CHEMICAL ATTACK

Map ref.: ----

GENERAL.

- General instructions and to whom applicable.
- Responsibilities of commanders for gas training and gas discipline. Training inspection.
- Coordination of gas defense plans.

GAS DANGER ZONE.

- Where, when, and how gas masks will be worn and used.
- Gas alarm systems.
- Construction and use of gasproof shelters.
- Arrangements for relief and rest in prolonged chemical attacks.

ADMINISTRATION AND PERSONNEL.

- Appointment and duties of gas officers and gas noncommissioned officers.
- Reports of gas officers and gas noncommissioned officers.
- Appointment of gas sentries.
- Instructions to gas sentries and military police concerning violations of gas discipline.

CHEMICAL INTELLIGENCE.

- Enemy gas procedure in general.
- Reports and records.
- Information from prisoners.

CHEMICAL DEFENSE OPERATIONS.

- Procedure to be followed in case of defensive installations by friendly troops.
- General tactical precautions to be observed in case of enemy gas attack.

PROCEDURE FOR GASED AREAS.

- Location and marking.
- Animal protection.
- Precautions taken on occupation.
- Decontamination procedures.

GAS CASUALTIES.

- Precautions in handling.
- System of evacuation.
- Front line first aid.
- Records.

SUPPLY.

- Special procedures for supply of protective appliances.
- Inspection of equipment.
- Salvage system in general.
- Supply of offense materials.

INDEX

	Paragraphs	Pages
Adjustment of gas mask.....	31, 79	63, 127
Aircraft attacks.....	11	18
Airing for decontamination.....	25f(4) (a)	39
Airplanes, decontamination of.....	27d	41
Alarm devices, gas.....	24	33
Animal—		
Protection.....	3, 69, 76	1, 113, 124
Training.....	73	119
Animals:		
Effect of chemical agents on.....	71, 76a	115, 124
First aid for.....	71	115
Military.....	69, 76	113, 124
Antidim, use of.....	34f	69
Areas, contaminated, occupation of.....	55d	94
Artillery shell attacks.....	9a	12
Artillery shell, chemical:		
Size of burst.....	9a	12
Types.....	9a	12
Bag, pigeon.....	76b	124
Battalion gas officers.....	44	77
Body parts of horse or mule.....	70	113
Bombs, chemical, attacks from.....	11a	18
Brigade gas officer.....	43	77
Buildings, decontamination.....	25f(7)	39
Bulk agents, chemical attacks from.....	13	20
Candles, cloud attacks from.....	12	19
Care of gas mask.....	34, 59, 82	67, 97, 139
Care of horse mask.....	74	123
Characteristics of chemical agents.....	6	5
Chemical agents:		
Characteristics.....	6	5
Classification.....	5	4
Definition.....	4	3
Effect of terrain on.....	16e	22
Effect of weather on.....	16	20
Effect on animals.....	71, 76a	115, 124
Identification.....	61	98
Proficiency in.....	3	1
Projection.....	8	12
Protection against.....	6	5
Chemical attack:		
Aircraft.....	11	18
Artillery shell.....	9a	12
Bombs.....	11a	18
Bulk agents.....	13	20
By chemical projectors.....	10a	16

INDEX

	Paragraphs	Pages
Chemical attack—Continued.		
Chemical projectors, HE attacks.....	10c	16
Chemical projectors, indications.....	10e	17
Chemical projectors, time of firing.....	10f	18
Cloud attacks:		
Agents used.....	12c	20
Description.....	12a	19
Time.....	12c	20
Conditions favorable for—	17	22
Incendiaries.....	17c	23
Nonpersistent.....	17a	22
Persistent.....	17b	23
Danger areas from.....	9c	13
Description.....	9	12
Detection of shell in.....	9e	15
Disposition of troops to meet.....	52	87
Drop size.....	11b	18
Effects of weather and terrain on.....	16	20
Grenades.....	14	20
Measures taken after.....	56	95
Mines, land.....	13	20
Mortar shell.....	9b	13
Object.....	7	12
Organization for defense against.....	41	75
Projector shell.....	10	16
Protection against, from the air.....	53	83
Protective measures against.....	9f, 18	15, 23
Smoke.....	15	20
Spray.....	11b	18
Standing orders for defense against.....	49	82
Types.....	9d	15
Chemical reconnaissance and intelligence.....	51	84
Classification of chemical agents:		
Physical state.....	5a	4
Physiological effect.....	5b	4
Tactical use.....	5c	4
Clothing:		
Decontamination.....	25f(4)	39
Protective.....	21	29
Collective protection.....	18b	24
Animal training in.....	73	119
Decontamination.....	25e	35
First aid for animals.....	71	115
Collective protector.....	23	33
Company gas noncommissioned officer.....	45	79
Contaminated areas, occupation.....	55d	94
Cylinders, cloud attacks from.....	12	19
Danger areas.....	9c	13
Designation.....	49a(1)	83
Inspection and determination.....	42b, 44c(1), 45	75, 77, 79
Decontamination.....	25	34
Airing.....	25f(4) (a)	39
Airplanes.....	27d	41
By steaming.....	25f(4) (b)	39
Food.....	26b	40
Instruments.....	27c	41

INDEX

	Paragraphs	Pages
Decontamination—Continued.		
Limitations.....	25b	35
Marking contaminated areas.....	25c	35
Materials:		
Bleach.....	25e (3)	36
Earth.....	25e (1)	36
Green solution.....	25e (5)	37
Noncorrosive.....	25e (6)	37
Sodium sulphide.....	25e (4)	37
Water.....	25e (2)	36
Methods of decontaminating—		
Buildings.....	25f (7)	40
Clothing.....	25f (4)	39
Fabric.....	25f (4)	39
Grass.....	25f (2)	38
Shell holes.....	25f (1)	37
Weapons.....	25f (3)	38
Of water.....	26c	40
Protection of degassing details.....	25a	34
Vehicles.....	27e	42
When to decontaminate.....	25d	35
Definitions:		
Casualty agent.....	4c	3
Chemical agent.....	4	3
Harassing agent.....	4d	3
Incendiary agent.....	4e	3
Irritant smoke.....	4i	4
Lacrimator.....	4h	4
Lung irritant.....	4f	4
Nonpersistent agent.....	4b	3
Persistent agent.....	4a	3
Screening smoke.....	4k	4
Standing orders.....	49a	82
Sternutator.....	4j	4
Vesicant.....	4g	4
Detonation, gas identification set.....	63	100
Devices, gas alarm.....	24	33
Discipline, gas.....	58	96
Disinfection of gas masks.....	34e, 82c	69, 141
Disposition of troops to meet chemical attack.....	52	87
Division chemical officer.....	42	75
Drill, gas mask.....	28, 79	42, 127
Duties of gas sentry.....	3	1
Equipment:		
Decontamination.....	25f (3)	38
Protection.....	27	40
Protective, basis of issue.....	19	24
Training.....	67	111
First aid for gas casualties:		
After chemical attack.....	56a	95
Animals.....	71	115
General.....	35	72
Incendiaries.....	40	74
Irritant smokes (sternutators).....	37	72
Lacrimators.....	36	72

INDEX

	Paragraphs	Pages
First aid for gas casualties—Continued.		
Lung irritants.....	38	72
Proficiency in.....	3	1
Vesicants.....	39	73
Fitting the gas mask.....	32, 80	63, 133
Fitting the horse mask.....	73	119
Fog, effect on chemical agents.....	16c	21
Food supplies:		
Decontamination.....	26b	40
Protection.....	26	40
Form for standing orders.....	App.	144
Garrison organization.....	46	80
Garrison storage.....	34i	70
Gas alarm devices.....	24	33
Gas chamber.....	32a (4), 84	64, 141
Gas discipline.....	58	96
Gas mask:		
Adjustment and removal during attack.....	31, 79	63, 127
Advice to company instructors.....	84	141
Care.....	34, 59, 60c, 82	67, 97, 98, 105
Description.....	20c	26
Deterioration.....	34d, 82a	68, 140
Disinfection.....	34e, 82c	69, 141
Fitting.....	32, 80	63, 133
Inspection.....	29, 34c, 80	57, 68, 133
Inspection in ranks.....	30, 81	61, 139
Issue pools.....	46b	80
Limitations and use (training).....	78	127
Nomenclature.....	20c	26
Principle of operation.....	20a	24
Repair.....	34d, 83	68, 141
Sizes.....	32, 77	63, 124
Standards of proficiency.....	3	1
Standards of proficiency for gas noncommis- sioned officers.....	64c	103
Storage.....	34i, 82b	70, 140
Test in drill.....	79	127
Testing in gas.....	32, 84	63, 141
Types:		
Diaphragm.....	20b (2)	26
Service.....	20b (1)	24
Training mask M1.....	77	124
Use by gas sentry.....	47d(1), 49a(6)	81, 83
Use in decontamination operations.....	25	34
Visual inspection.....	29, 80	57, 133
Wearing.....	33, 78	66, 127
Gas mask drill:		
Proficiency in.....	3	1
Recruit training.....	28, 59, 60c, 66, 78	42, 97, 98, 105, 127
Test in.....	79	127
Gas noncommissioned officers:		
Ability in individual protection.....	64h, 65	104
Company.....	45	79
Duties.....	45	79

INDEX

	Paragraphs	Pages
Gas noncommissioned officers—Continued.		
Standards of proficiency for.....	64	103
Training.....	65	104
Gasproof shelters:		
Blanket doors, construction.....	22 <i>c</i>	30
Location.....	22 <i>a</i>	29
Principles of construction.....	22 <i>b</i>	30
Proficiency in.....	3	1
Ventilation.....	22 <i>d</i>	33
Gas sentries:		
Duties.....	3, 47	1, 80
Special.....	48	82
Grenades, chemical:		
Agents.....	14	20
Area of burst.....	14	20
Horse:		
Body, parts.....	70	113
Digestive tract.....	70 <i>d</i>	115
Feet.....	70 <i>c</i>	114
Respiratory system.....	70 <i>a</i>	113
Skin.....	70 <i>b</i>	114
First aid for.....	71	115
Training.....	73	119
Horse mask:		
Adjustment.....	73 <i>a</i>	119
Care.....	74	123
Carrier, MIII or MIIIA1.....	72 <i>d</i>	119
Inspection.....	75	123
Removal.....	73 <i>b</i>	122
Types:		
MII.....	72 <i>a</i>	118
MIII.....	72 <i>b</i>	118
MIIIA1.....	72 <i>c</i>	119
Wearing exercises.....	73 <i>c</i>	123
Identification of chemical agents.....	61	98
Incendiaries, first aid for.....	40	74
Individual protection:		
Ability of gas noncommissioned officers in.....	64 <i>h</i> , 65	104
Against chemical agents.....	6	5
Definition.....	18 <i>a</i>	23
First aid for.....	35-40	72
Gas mask for.....	20	24
Protective clothing for.....	21	29
Standards of proficiency.....	3	1
Tests for.....	84	141
Training in.....	60 <i>c</i>	98
Training in identification.....	61	98
Instruction:		
Object.....	1	1
Schedule.....	64, 65, 84	103, 104, 141
Scope.....	2	1
Instructional, gas identification set.....	62	99
Intelligence, chemical.....	51 <i>b</i>	84
Irritant smokes (sternutator).....	6	5
First aid for.....	37	72

INDEX

	Paragraphs	Pages
Lacrimators -----	6	5
Definition -----	4 <i>h</i>	4
First aid for -----	36	72
Land mines, chemical -----	13	20
Lung irritants -----	6	5
Definition -----	4 <i>f</i>	4
First aid for -----	38	72
Marching columns, protection -----	53 <i>d</i>	89
Measures taken after chemical attack -----	56	95
Methods of decontamination -----	25 <i>f</i>	37
Military animals -----	69	113
Mines, land:		
Agents used -----	13	20
Area burst -----	13 <i>b</i>	20
Mortars:		
Description -----	9 <i>b</i>	13
Size of shell burst -----	9 <i>b</i>	13
Motor convoys, protection -----	53 <i>c</i>	89
Mules (see <i>Horse</i>) -----	70	113
Munitions, protection -----	27	40
Noncommissioned officers, gas:		
Appointment -----	45	79
Duties -----	45	79
Organization -----	41, 45	75, 79
Requirements -----	64	103
Standards of proficiency for -----	64	103
Training -----	65	104
Object of instruction -----	1	1
Occupation of contaminated areas -----	55 <i>d</i>	94
Occupation of new position -----	54 <i>e</i>	93
Organization against chemical attack -----	41	75
Organization, proficiency in -----	3 <i>b</i>	3
Phases of training -----	60	97
Pigeon bag -----	76 <i>b</i>	124
Pigeons:		
Effect of chemical agents on -----	76 <i>a</i>	124
Protection -----	76 <i>b</i>	124
Projection of chemical agents -----	8	12
Projectors, chemical:		
Area of burst -----	10 <i>d</i>	17
Description -----	10 <i>a</i>	16
Filling for -----	10 <i>d</i>	17
HE attacks -----	10 <i>c</i>	16
Indications -----	10 <i>e</i>	17
Time of firing -----	10 <i>f</i>	18
Protection:		
Against chemical attack from air -----	53	88
Animal -----	3, 69, 76	1, 113, 124
Collective:		
Animal training in -----	73	119
Decontamination -----	25 <i>e</i>	35
Definition -----	18 <i>b</i>	24
First aid for animals -----	71, 76 <i>b</i>	115, 124

INDEX

Protection—Continued.	Paragraphs	Pages
During combat.....	55	93
During movements into combat.....	54	91
Individual:		
Ability of gas noncommissioned officers in.....	64 <i>h</i> , 65	104
Against chemical agents.....	6	5
Clothing for.....	21	29
Definition.....	18 <i>a</i>	23
First aid for.....	35-40	72
Gas masks for.....	20	24
Identification.....	61	98
Standards of proficiency for.....	3	1
Tests for.....	84	141
Training in.....	60 <i>c</i>	98
Of food.....	26	40
Of supplies, equipment, and munitions.....	27	40
Of water.....	26	40
Proficiency in.....	3	1
Tactical:		
Decontamination.....	25 <i>e</i> , 25 <i>f</i>	35
Definition.....	18 <i>c</i> , 50	24, 84
Scope.....	50	84
Staff functions in.....	57	95
Protective clothing.....	21	29
Protective equipment, basis of issue.....	19	24
Protective measures, classification.....	18	23
Protector, collective.....	23	33
Pursuit, protection during.....	55 <i>e</i>	95
Racks, storage.....	34 <i>i</i>	70
Rail movements, protection.....	53 <i>b</i>	88
Rain, effect on chemical agents, general.....	16 <i>c</i>	21
Reconnaissance, chemical.....	51 <i>a</i>	84
Recruit training.....	28, 59, 60 <i>c</i> , 65, 66, 78	42, 97, 98, 104, 105, 127
Regimental gas officers.....	44	77
Removal of gas mask.....	31, 79	63, 127
Rules to be remembered.....	68	111
Scope of instruction.....	2	1
Sentries, gas, special.....	48	82
Set, gas identification:		
Detonation.....	63	100
Instructional.....	62	99
Shelters, gasproof:		
Blanket doors, construction.....	22 <i>c</i>	30
Location.....	22 <i>a</i>	29
Principles of construction.....	22 <i>b</i>	30
Ventilation.....	22 <i>d</i>	33
Smoke:		
Employment in chemical attack.....	15	20
First aid for.....	37	72
Irritant (sternutator).....	6	5
Screening.....	6	5
Spray, chemical, attacks from.....	11 <i>b</i>	18
Staff functions of chemical service.....	57	95

INDEX

	Paragraphs	Pages
Standards of proficiency:		
For gas noncommissioned officers.....	64	103
For individuals.....	3a	1
For organizations.....	3b	3
Standing orders for defense against chemical attacks.....	49	82
Standing orders, form.....	App.	144
Storage racks.....	34i	70
Supplies, protection:		
Equipment and munitions.....	27	40
Food and water.....	26	40
Tactical protection:		
Decontamination.....	25e, 25f	35, 37
Definition.....	18c, 50	24, 84
Scope.....	50	84
Staff functions in.....	57	95
Tactical use of chemical agents.....	5c	4
Temperature, effect on agents.....	16b	21
Terrain.....	16e	22
Time of day, effect on chemical agents.....	16d	21
Training:		
Animal.....	73	119
Equipment.....	67	111
Mask.....	App.	144
Noncommissioned officers.....	65	104
Phases.....	60	97
Recruit.....	28, 59, 60c, 65, 66, 78	42, 97, 98, 104, 105, 127
Troops.....	66	105
Unit gas officers.....	65	104
Troops, training.....	66	105
Types of chemical attacks.....	9d	15
Unit gas officers:		
Duties.....	43, 44	77
Organization.....	41	75
Training.....	65	104
Vesicants.....	6	5
First aid for.....	39	73
Water:		
Decontamination.....	26c	40
Protection.....	26	40
Weapons:		
Decontamination.....	25f(3)	38
Projector, chemical.....	10b	16
Protection.....	27	40
Wearing exercises for horse mask.....	73c	123
Wearing the gas mask.....	33, 84	66, 141
Weather, effect on chemical attacks.....	16	20
Wind:		
Effect on nonpersistent agents.....	16a	20
Effect on persistent agents.....	16a	20





