

VIRUSES AS VEHICLES OF GENETIC CHANGE

Required Reading: Chapter 46 in Davis et al., Microbiology, 2nd edition.
(For additional reading, see Chapter 9 in Davis; 2 publications of the Cold Spring Harbor Laboratory: The Bacteriophage Lambda and Phage and the Origins of Molecular Biology, especially chapter by Lwoff; J.D. Watson, The Molecular Biology of the Gene, 3rd edition.)

Highly Recommended: S.N.Cohen: Gene Manipulation, New Engl. J. Med. 294:883-889, Apr. 15, 1976.

This lecture is intended as an introduction to mechanisms by which viruses can enter into relationships with their host cells that differ from classical lytic infections. Thus viruses can become cryptic in infected cells, yet confer new properties upon them, and viruses can act as vehicles for transfer of stably inherited genetic information between cells. Naked nucleic acids, both cellular and viral, can be considered "infectious" in the sense that they can introduce usable genetic information into host cells; in this respect, cellular DNA, particularly bacterial plasmid DNA, appears closely related to viral genomes, suggesting evolutionary relationships between viruses and plasmids. The considerations raised here provide a framework for proposing approaches to genetic engineering, in particular to the amplification of specific genes in bacteria ("cloning") and the more improbable therapy of genetic diseases.

I. Lysogeny. Lysogenic bacteria contain a viral genome in a repressed state, and they may, spontaneously or after "induction," ultimately produce mature, lytic virus. The bacteriophage lambda is the best studied example of a "temperate" bacterial virus (one which is capable of lysogenizing cells).

The life cycle of lambda phage:

- Injection of linear viral DNA
- Circularization of the DNA and production of "early" gene products
- Phase of uncertainty: vegetative pathway to virus production and cell lysis versus lysogenic pathway to viral gene repression

To enter the lysogenic pathway, repressor (the protein product of viral gene C_I , capable of blocking transcription of "early" genes required for viral replication) dominates over other viral genes (especially the early gene cro, which interferes with production of repressor).

Stable lysogeny requires recombination (integration) of the circular viral genome with the circular bacterial chromosome by a single "crossing over" event; in the case of lambda, this event normally occurs at a specific site in both DNA's; the event requires the action of viral gene(s). The integrated viral genome is called the prophage.

Maintenance of lysogeny: continuous production of repressor maintains repression of other viral genes and immunity to superinfection by similar viruses.

Induction: UV radiation or cytotoxic chemicals can inactivate repressor by uncertain mechanisms; increased temperature can induce prophage mutants which produce heat sensitive repressor.

Inactivation of repressor is followed by:

- (1) Expression of early genes: cro (augments repressor shutoff);
N (antiterminator: allows transcription into adjacent genes)
- (2) Expression of genes adjacent to N and cro, which are required for excision of prophage and replication of DNA
- (3) Expression of late genes for structural proteins of phage and for cell lysis.

Lysogenic cells may contain only one new product (repressor), but in some cases they contain other new products; some of these are of medical importance (eg, diphtheria toxin, streptococcal toxins, and some other toxins are found only in lysogenic bacteria).

Prophage may also influence expression of bacterial genes; the best example is provided by Mu-1 phage (mutator phage) which may integrate its DNA at any point in the cellular genome and thereby interrupt a cellular gene or operon (coordinated set of genes).

Lysogeny poses an important model for understanding tumor viruses and, perhaps, certain "slow" viruses and certain "latent" infections.

II. Transduction. Viruses can promote the exchange of genetic information between cells (bacteria, plant, or animal), either by packaging host DNA in a viral coat or by recombining its genome with a piece of the host genome. If the recombination tends to occur at a specific site in the host genome, certain genes are likely to be transferred by that virus; this is called "specific" or "specialized" transduction. (Example: lambda phage transducing the gal or bio operons, which are close to the lambda integration site on the bacterial chromosome.) If the recombination occurs randomly (as in the case of Mu-1 phage), or if host DNA is randomly packaged in a viral coat (as in the case of P1 or P22 phage), the transduction of virtually any host gene may occur, and the event is called "generalized" transduction. Since there are limitations upon the amount of DNA which can fit inside the viral coat, viral genomes which have added cellular genes may have lost critical viral genes and have become "defective" viruses. This means they are unable to replicate without a "helper" (non-defective) virus in the same cell, supplying the product of the missing gene. Packages of host DNA in viral coats cannot replicate and are referred to as "pseudoviruses." For successful and stable transduction in this case, the transferred cellular DNA must recombine with the chromosome of the recipient host cell.

III. Plasmids and other Forms of Infectious, Nonviral DNA. Plasmids are circular DNA molecules, generally 10^6 to 10^8 daltons in molecular weight, which can replicate autonomously in cells; some plasmids can integrate into the host chromosome, and some can direct bacterial conjugation, but they are not normally required for survival of the bacteria; although they have been thus far studied principally in bacteria, they may well exist in eukaryotic cells as well (eg, mitochondrial DNA can be considered a plasmid). In bacteria,

plasmids are extremely common; most strains of some bacterial species will carry one or more plasmids. Most plasmids fall into three major categories of plasmids with a wide variety of functions, and with various relationships with the host chromosome:

(1) F (fertility) factors: large plasmids which can direct bacterial mating (conjugation) for transfer of F factor itself and for transfer of any bacterial genes which have recombined with it. The F factor can also integrate into the host chromosome; from this position, it can direct transfer of host genes from one bacterium to another.

(2) Resistance transfer factors (RTF's): an assortment of plasmids which can render the host resistant to antibiotics (mechanisms will be considered in detail in the fall quarter, and are of paramount importance in determining clinical efficacy of antibiotics); they also direct conjugation for transfer of these factors from cell to cell, even between species of bacteria.

(3) Toxin-producing plasmids: these produce factors toxic either for other bacteria (eg, colicins, a variety of chemicals toxic for *E. coli*) or for animals (eg, enterotoxins, producing diarrhea in man and other animals).

In addition to being transmissible via bacterial conjugation, naked plasmid DNA, like viral DNA or host cell DNA, is infectious. Since plasmid DNA contains the elements required for its replication, it need not integrate to successfully "infect" a cell. Pieces of host DNA, however, cannot replicate and therefore must integrate into the genome of the recipient cells, as in the case of generalized transduction by pseudovirions (see above). "Infection" of cells by plasmid or host DNA is called "transformation" but should not be confused with the change in behaviour of animal cells (also called "transformation") that is induced by infection with tumor viruses (see next lecture).

A new class of DNA molecules capable of making rapid genetic changes in cells has recently been discovered. These are relatively short segments of DNA, called "translocation sequences" or "insertion sequences," which may perform important functions (eg, direct resistance to antibiotics), and which can jump, in a block, by unknown mechanisms, from one larger DNA molecule to another.

Virus-mediated transduction, transformation by host or plasmid DNA, and migration of translocation sequences all suggest that evolution can occur much more rapidly than can be accomplished by a series of simple point mutations. The mechanisms discussed permit genes developed during evolution of one organism to be "shared" by others, thus hastening their development. The degree to which genetic change is mediated by such mechanisms in nature is, however, unknown, although these mechanisms have all been observed under "natural" conditions.

There are some obvious differences between plasmids and DNA viruses - viruses are more highly developed in that they can usually direct the synthesis of coat proteins, often have highly regulated patterns of gene expression (cf lambda), and may lyse their host cells. However, the structure, replication, integrative capacity, and infectivity of their DNA's are very similar. When a defective, transducing virus is compared with plasmid containing host genes, the differences may seem very small indeed. For these reasons, it is generally thought that plasmids and viruses are closely

related, perhaps having arisen similarly from host chromosomes and evolved to different degrees.

IV. Gene Transfer by Genetic Engineering. We have considered some ways in which viruses and plasmids, occurring naturally, are able to effect the transfer and replication of genetic information. It is also possible in the laboratory to recombine viruses or plasmids with genetic material from virtually any source for a variety of purposes. Several technical advances have made the manufacture of such "recombinant" (or "chimeric") molecules possible (1) biochemical procedures for adding homopolymeric "tails" (eg, dAdAdAdA... and dTdTdTdT...) to DNA molecules one desires to join; (2) the discovery of nucleases ("restriction endonucleases") capable of making site-specific (and often "staggered") cleavages of DNA which also allow joining of DNA molecules (see slides). In addition, advances in the genetics of viruses, bacteria, and plasmids; in the purification of single genes; in the synthesis of nucleic acids de novo; and in the preparation of DNA from purified messenger RNA (by "reverse transcriptase," see tumor virus lecture) have expedited the development of genetic engineering.

The basic strategy in most "genetic engineering" proposals is to join some specific gene (the "donor" DNA) with at least the replication-competent part of viral or plasmid DNA (the "vector" DNA). The "hybrid" molecule is then used to "transform" a recipient cell, most commonly a bacterial cell. The process of "infecting" a single cell with a defined piece of DNA and growing the progeny of that single cell is referred to as the "cloning" of DNA. Since the progeny cells can be grown in large number and may contain hundreds of copies of the cloned DNA per cell, it is possible to prepare very large amounts of single genes for detailed study (eg, DNA sequencing, etc). (The human beta-globin gene has already been "cloned" for such purpose.) In addition, it might be possible to produce large amounts of the protein product of the "cloned" gene in the recipient cell. Lastly, and more remotely, it might be possible to prepare "cloned" genes for delivery to patients with genetic deficiencies (gene therapy").

There are many problems and dangers, as well as potential benefits, associated with this general strategy for cloning and gene therapy:

Difficulties with cloning:

(1) Could certain DNA molecules, produced in large amounts in bacterial cells, pose a medical danger? (For example, an "oncogene" from mammalian DNA? See tumor virus lecture.)

(2) Will the use of certain vectors, eg, certain plasmids, lead to the spread of unwanted genes, eg, those determining resistance to antibiotics?

(3) Can a "safe" vector and recipient cell be created which will prevent the possibility that cells containing cloned DNA would grow in the human intestine? Or can safe facilities be constructed for growing potentially dangerous material?

Difficulties with gene therapy:

(1) Can the necessary gene be identified, purified, and prepared in sufficient quantities?

(2) Can the genetic disease really be cured by administration of a gene? (Multigenic diseases like diabetes or Mendelian dominant disorders would likely be resistant to gene therapy; recessive point mutations or gene deletions might be susceptible to it.)

(3) How can the gene be delivered to sufficient numbers of cells to affect the patient?

(4) Will the delivered gene be perpetuated and function properly in the recipient cells? (For example, will it replicate or be integrated? Will it be properly controlled at transcriptional and translational levels?)

(5) What are the chances that unwanted genetic material or mutated DNA will be delivered and expressed? Or that the integration of new DNA within a normal gene will disturb the function of the normal gene (as in the example of Mu-1 phage, see above)?

The consensus at present (if there is one) is that gene therapy is currently impractical and of less use than its alternative (genetic counseling or other forms of treatment, eg, replacement of the missing gene product or drug therapy). The dangers of cloning, however, can be minimized by judicious selection of the DNA to be cloned, the vector, and the recipient cell, and by use of the proper techniques and facilities. Rather stringent guidelines governing such research have recently been recommended by the scientific community and are the subject of public debate.

- SLIDES -COMPARISON OF EXTRACHROMOSOMAL ELEMENTS

	<u>TRANSDUCING VIRUS</u>	<u>PLASMID</u>	<u>TRANSLOCATION SEQUENCES</u>
DIRECTS CONJUGATION	-	+ or -	-
CODES FOR COAT PROTEIN DIRECTS CELL LYSIS	+ (UNLESS DEFECTIVE)	-	-
DNA CIRCULARIZES	+	+	(+)
DNA INTEGRATES	+	+	+
DNA RECOMBINES WITH HOST DNA	+	+	+
DNA IS INFECTIOUS	+	+	(+)
DNA SIZE (MW)	3 - 30 x 10 ⁶	10 ⁶ - 10 ⁸	Ca. 5 x 10 ⁵

GENE TRANSFER

<u>MODE</u>	<u>AGENT</u>	<u>GENES TRANSFERRED</u>
TRANSFORMATION	NAKED DNA	HOST, PLASMID, OR VIRAL
CONJUGATION	(MEDIATED BY FREE OR INTEGRATED PLASMID)	PLASMID OR BACTERIAL GENES
TRANSDUCTION	VIRUS PARTICLE	HOST DNA (MAY BE LINKED TO VIRAL DNA)
"CLONING"	HYBRID DNA (PLASMID OR VIRAL PLUS ANYTHING)	ANY
GENE THERAPY	DNA OR VIRUS PARTICLE	ANY

LYSOGENY BY LAMBDA PHAGE

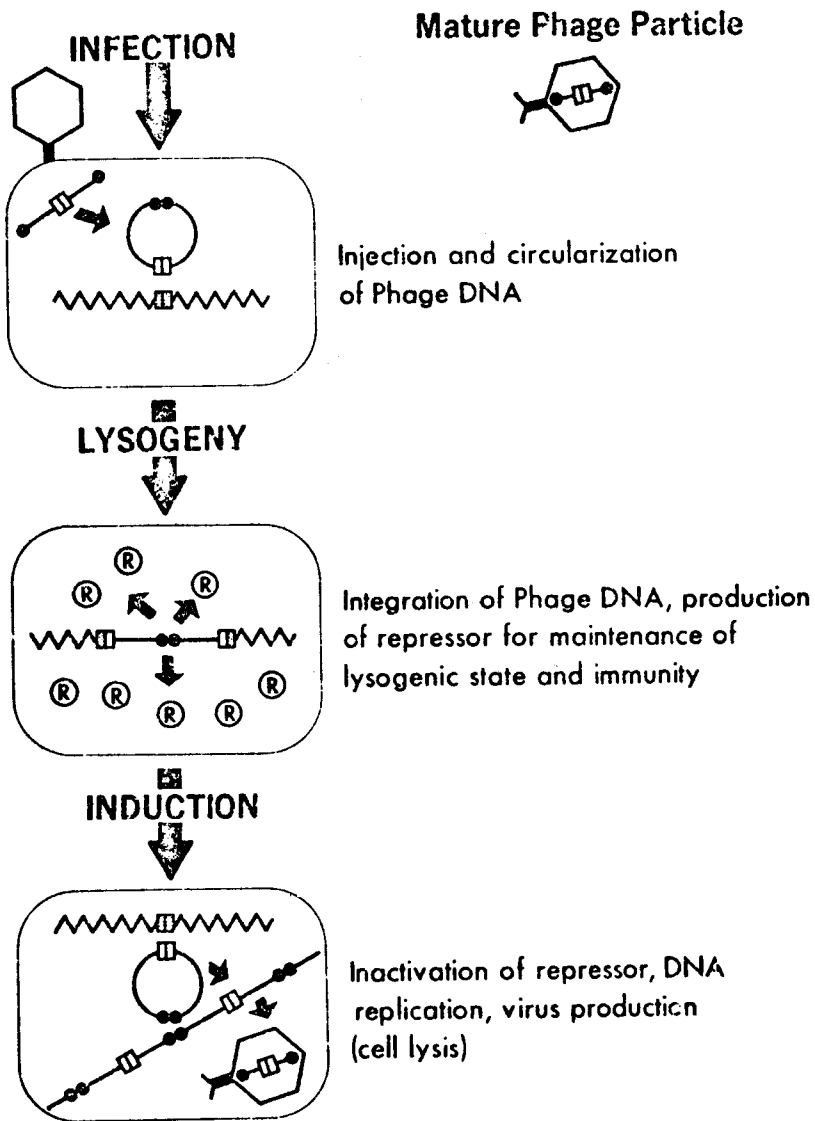

LYSOGENY BY MU-1 PHAGE

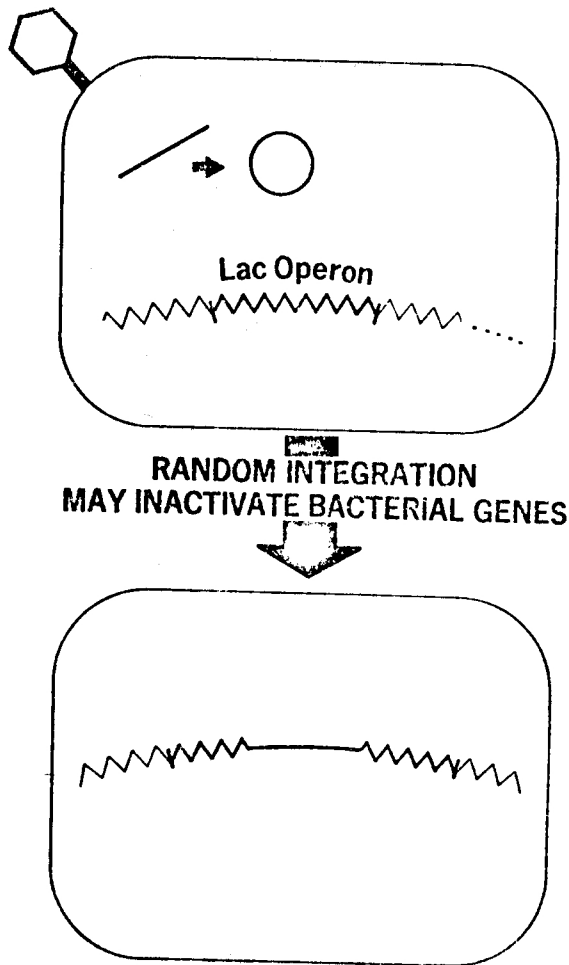

MECHANISM OF INDUCTION

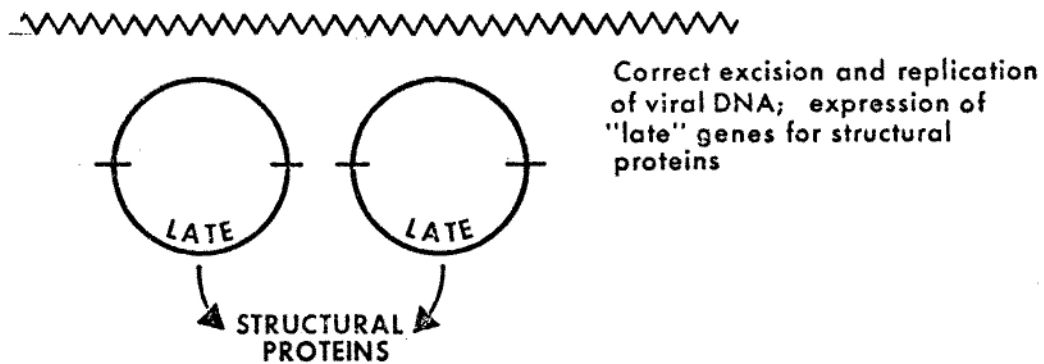
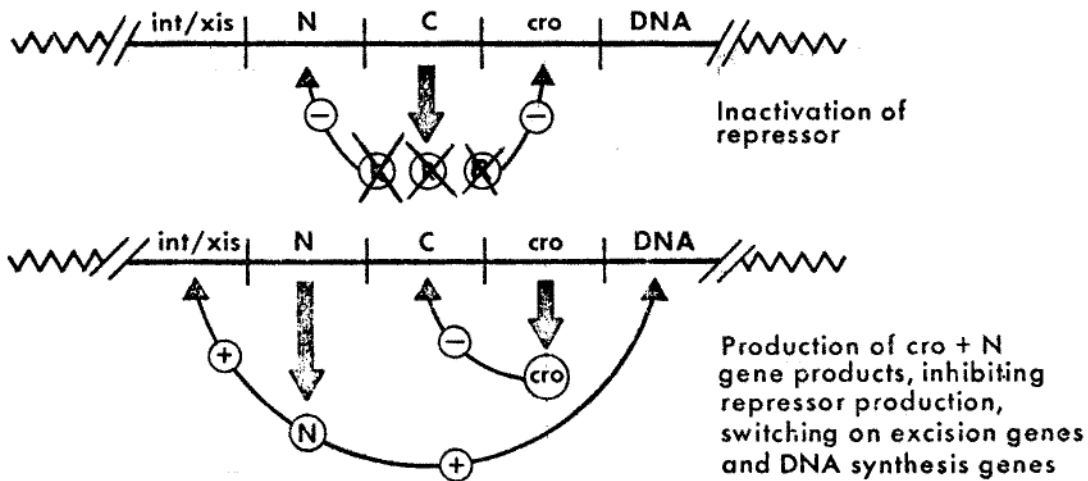

VIRUS-MEDIATED TRANSDUCTION

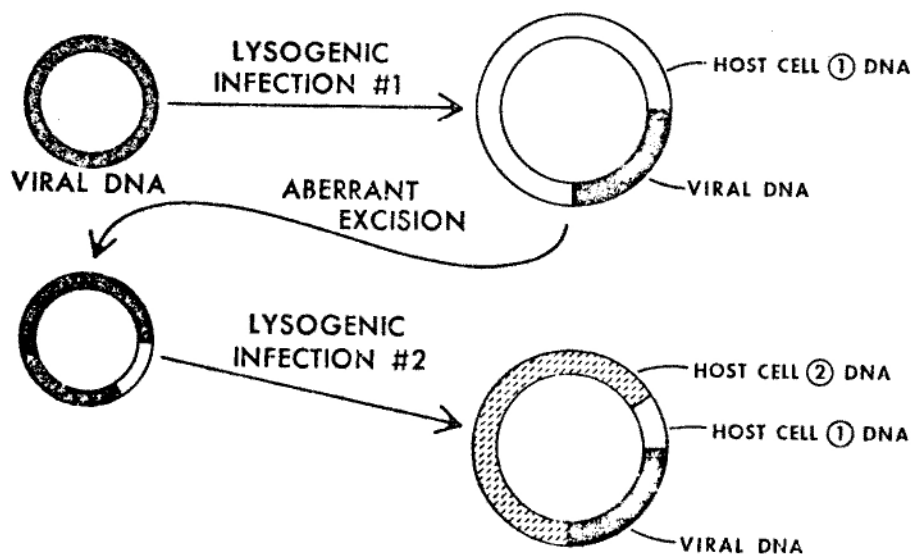

PACKAGING OF HOST CELL DNA: A MECHANISM FOR GENERALIZED TRANSDUCTION

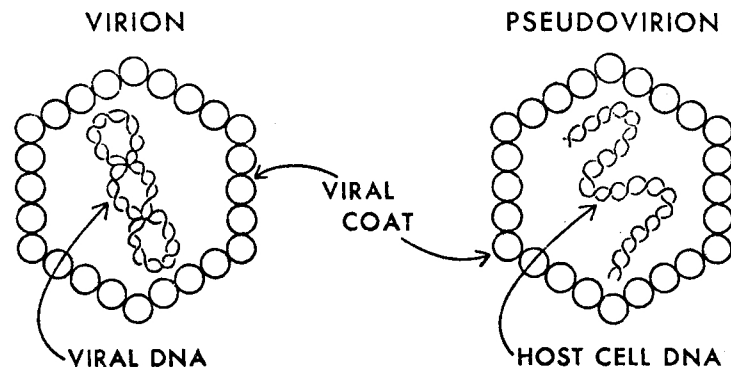

BEHAVIOR PATTERNS FOR BACTERIAL PLASMIDS

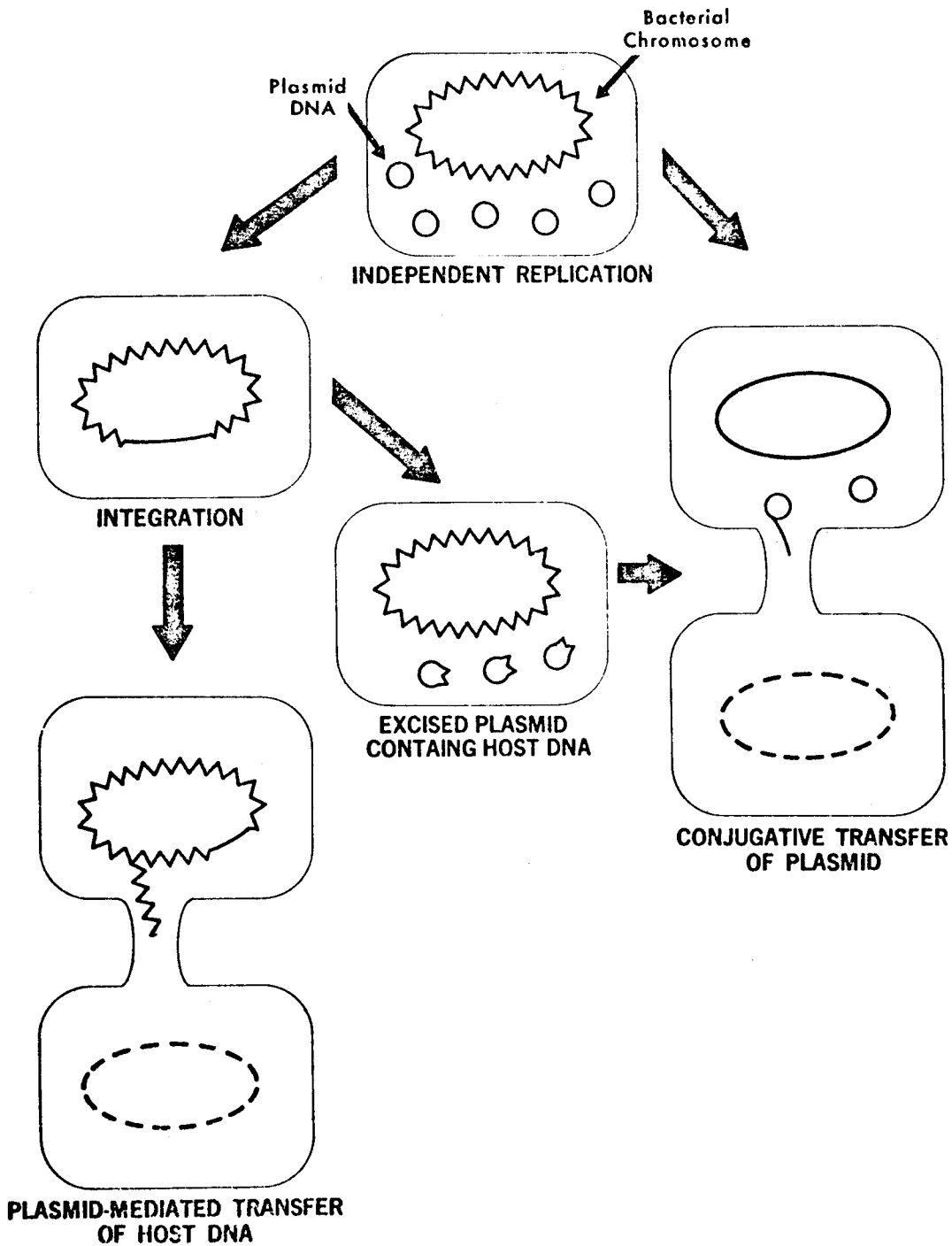

GENETIC ENGINEERING: HYBRID DNA

I HOMOPOLYMERIC TAILS

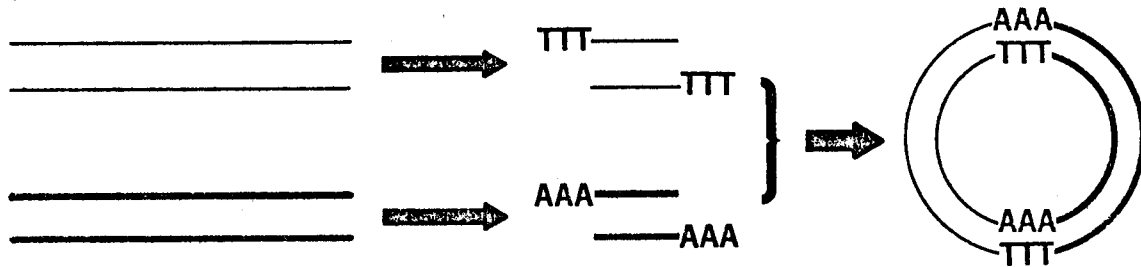

II ENDONUCLEASE-GENERATED "STICKY ENDS"

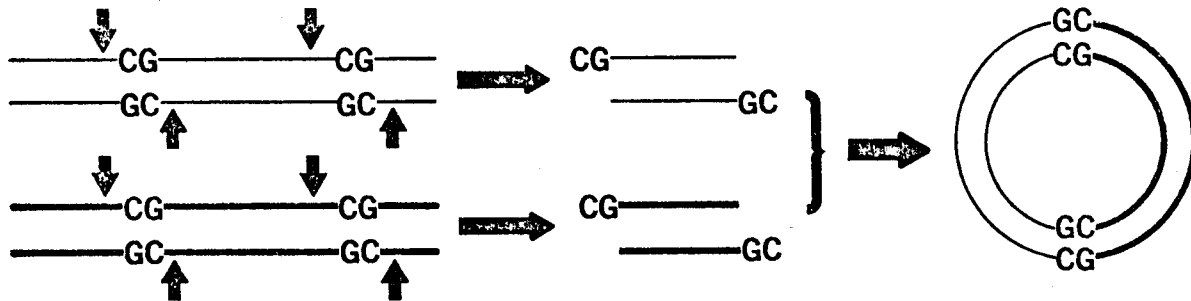

STRATEGY FOR GENETIC ENGINEERING

